

# **FLORIDA DEPARTMENT OF TRANSPORTATION**



**DOT-ITB-20-8025-AC**

**GENERATOR, FUEL TANK AND AUTOMATIC TRANSFER SWITCH (ATS) REPLACEMENT  
AT MID-BAY BRIDGE ADMINISTRATION BUILDING, SR 293, MILEPOST 5.0**

**FPID: 413878-1-93-11**

**ADVERTISEMENT**  
**INVITATION TO BID**  
**STATE OF FLORIDA DEPARTMENT OF TRANSPORTATION**  
**FLORIDA'S TURNPIKE ENTERPRISE**

Sealed Invitation to Bid Packages will be received by the State of Florida, Department of Transportation, Florida's Turnpike Enterprise, Contractual Services Office, Building 5315 on Florida's Turnpike, Milepost 263.0, Turkey Lake Service Plaza, Ocoee, Florida, 34761, on or before **2:30 P.M. (local time) on Friday, February 28, 2020** for the following project:

**BID NO.: DOT-ITB-20-8025-AC**

**SCOPE:** The Florida Department of Transportation, Florida's Turnpike Enterprise (hereinafter referred to as the "Department") seeks the services of a licensed, insured, and experienced Vendor to provide all labor, materials, equipment, and incidentals necessary to perform the replacement of existing emergency standby generator, fuel tank and automatic transfer switch (ATS) including providing temporary portable emergency standby generator at Mid-Bay Bridge Administration Building. All equipment and materials used by the Vendor shall be completely free of any type of asbestos materials.

**Vendor's Qualifications**

The Vendor shall maintain and keep in force throughout the life of the Contract, renewals, and extensions, the requirements specified below. Failure of the Vendor to comply with these requirements will be sufficient grounds for the Department to declare the Vendor in accordance with the terms of Section 6; Termination and Default, of the Standard Written Agreement.

- Certification and Registration

The Vendor providing services shall hold and keep in force during the term of the Contract, a valid and current certificate/license, in accordance with the laws of the State of Florida, authorizing the Vendor, or approved sub-vendor, to perform the specified work and have all required federal, state, and local licenses and permits. A copy of all required licenses and/or certifications for this Contract shall be submitted and included with the Vendor's bid package.

All sub-vendors shall be properly licensed meeting the requirements under the respective trade category for the work to be performed under this Contract.

- Business Location

The Vendor shall have a current and valid Business Tax Receipt which states the name of the Vendor, street address of the business where all the work covered under the Contract will be handled, and the type of work that the Business Tax Receipt is issued for (which must be for the same type of services required in the Contract). If awarded the Contract, the Vendor shall be required to provide the Department verification of a Business Tax Receipt in the county the services are being provided (Okaloosa) at the Pre-work Conference.

- Certification of Experience

The organized business enterprise (e.g. corporation, LLC or sole proprietorship) shall have been licensed and actively involved in the type of business requested in the scope of work for this Contract for a minimum of three (3) years. The Vendor shall submit documentation of the work experience with its bid package.

- Performance Bond

Prior to commencement of any services pursuant to this Contract and at all times during the term hereof, including renewals and extensions, the Vendor will supply to the Department and keep in force a bond provided by a surety company authorized to do business in the State of Florida, payable to the Department and conditioned for the prompt, faithful, and efficient performance of this Contract according to the terms and conditions hereof and within the time periods specified herein, and for the prompt payment of all persons furnishing labor, materials, equipment, and supplies therefore.

The bidder must submit, with its bid, a current letter from a surety company or bonding agent authorized to do business in the State of Florida and written on company letterhead, to document the bidder's present ability to obtain a Performance Bond in the full amount of the bid. Failure by the bidder to provide this letter with its bid will constitute a non-responsive determination for its bid.

The Department will review carefully to determine the Vendor is responsive, responsible, and qualified in the area of work contemplated by the Contract.

**All Bidders, Proposers, and Respondents must be registered in the State of Florida's MyFloridaMarketPlace system.** All prospective bidders, proposers, and respondents that are not registered, should go to <https://vendor.myfloridamarketplace.com/> to complete on-line registration, or call 1-866-352-3776 for assisted registration.

**For services contracts, all out-of-state corporations, out-of-state limited liability companies, and out-of-state limited partnerships must be authorized to do business in the State of Florida.**

For authorization, contact:

Florida Department of State  
Tallahassee, Florida 32399  
(850) 245-6051

**For services contracts, all Bidders, Proposers, and Respondents must be properly licensed if the business being provided requires that individuals be licensed by the Florida Department of Business and Professional Regulation.**

For licensing, contact:

Florida Department of Business and Professional Regulation  
Tallahassee, Florida 32399  
(850) 487-1395

**NOTE:** In accordance with Section 287.057(23), Florida Statutes, respondents to this solicitation or persons acting on their behalf may not contact, between the release of the solicitation and the end of the seventy-two (72) hour period following the agency posting the notice of intended award, excluding Saturdays, Sundays, and state holidays, any employee or officer of the executive or legislative branch concerning any aspect of this solicitation, except in writing to the procurement officer or as provided in the solicitation documents. Violation of this provision may be grounds for rejecting a response.

**Public Meeting Notices and Meeting Agendas:**

Notice of the public meetings scheduled for this solicitation is provided in the timeline of the attached solicitation, with agendas for the public meetings.

**MFMP Transaction Fee:**

All payment(s) to the Vendor resulting from this competitive solicitation WILL be subject to the MFMP Transaction Fee in accordance with the referenced Form PUR 1000 General Contract Condition #14. The Transaction Fees imposed shall be based upon the date of issuance of the payment.

**Scrutinized Companies Lists**

Section 287.135, Florida Statutes prohibits a company from bidding on, submitting a proposal for, or entering into or renewing a contract for goods or services of any amount if, at the time of contracting or renewal, the company is on the Scrutinized Companies that Boycott Israel List, created pursuant to Section 215.4725, Florida Statutes, or is engaged in a boycott of Israel. Section 287.135, Florida Statutes, also prohibits a company from bidding on, submitting a proposal for, or entering into or renewing a contract for goods or services of \$1,000,000 or more, that are on either the Scrutinized Companies with Activities in Sudan List or the Scrutinized Companies with Activities in the Iran Petroleum Energy Sector Lists which were created pursuant to Section 215.473, Florida Statutes.

## **Title VI of the Civil Rights Act of 1964**

**COMPLIANCE WITH NONDISCRIMINATION STATUTES AND AUTHORITIES:** Title VI of the Civil Rights Act of 1964 (42 U.S.C. § 2000d et seq., 78 stat. 252), (prohibits discrimination on the basis of race, color, national origin); and 49 CFR Part 21; The Uniform Relocation Assistance and Real Property Acquisition Policies Act of 1970, (42 U.S.C. § 4601), (prohibits unfair treatment of persons displaced or whose property has been acquired because of Federal or Federal-aid programs and projects); Federal-Aid Highway Act of 1973, (23 U.S.C. § 324 et seq.), (prohibits discrimination on the basis of sex); Section 504 of the Rehabilitation Act of 1973, (29 U.S.C. § 794 et seq.), as amended, (prohibits discrimination on the basis of disability); and 49 CFR Part 27; The Age Discrimination Act of 1975, as amended, (42 U.S.C. § 6101 et seq.), (prohibits discrimination on the basis of age); Airport and Airway Improvement Act of 1982, (49 USC § 471, Section 47123), as amended, (prohibits discrimination based on race, creed, color, national origin, or sex); The Civil Rights Restoration Act of 1987, (PL 100-209), (Broadened the scope, coverage and applicability of Title VI of the Civil Rights Act of 1964, The Age Discrimination Act of 1975 and Section 504 of the Rehabilitation Act of 1973, by expanding the definition of the terms “programs or activities” to include all of the programs or activities of the Federal-aid recipients, sub-recipients and contractors, whether such programs or activities are Federally funded or not); Titles II and III of the Americans with Disabilities Act, which prohibit discrimination on the basis of disability in the operation of public entities, public and private transportation systems, places of public accommodation, and certain testing entities (42 U.S.C. §§ 12131 - 12189) as implemented by Department of Transportation regulations at 49 C.F.R. parts 37 and 38; The Federal Aviation Administration’s Non-discrimination statute (49 U.S.C. § 47123) (prohibits discrimination on the basis of race, color, national origin, and sex); Executive Order 12898, Federal Actions to Address Environmental Justice in Minority Populations and Low-Income Populations, which ensures non-discrimination against minority populations by discouraging programs, policies, and activities with disproportionately high and adverse human health or environmental effects on minority and low-income populations; Executive Order 13166, Improving Access to Services for Persons with Limited English Proficiency, and resulting agency guidance, national origin discrimination includes discrimination because of limited English proficiency (LEP). To ensure compliance with Title VI, you must take reasonable steps to ensure that LEP persons have meaningful access to your programs (70 Fed. Reg. at 74087 to 74100); Title IX of the Education Amendments of 1972, as amended, which prohibits you from discriminating because of sex in education programs or activities (20 U.S.C. 1681 et seq).

## **INSPECTOR GENERAL**

The Contractor/Consultant/Vendor agrees to comply with Section 20.055(5), Florida Statutes, and to incorporate in all subcontracts the obligation to comply with Section 20.055(5), Florida Statutes.

**HOW TO APPLY:** Prospective bidders may obtain a complete Invitation to Bid (ITB), including specifications and general bid conditions for the above-referenced project by copying the link below into your browser:

[http://www.myflorida.com/apps/vbs/vbs\\_search\\_r2.matching\\_ads](http://www.myflorida.com/apps/vbs/vbs_search_r2.matching_ads)

**NO PRE-BID CONFERENCE WILL BE HELD.**

**The Department reserves the right to reject any or all bids.**

**NOTE:** All of the Department’s ITB/RFP/ITN ADVERTISEMENTS appear on the Internet at website:

[http://www.myflorida.com/apps/vbs/vbs\\_main\\_menu](http://www.myflorida.com/apps/vbs/vbs_main_menu) click on “Search Advertisements,” click on the drop-down arrow beside the box under Agency, select DEPARTMENT OF TRANSPORTATION, then go to the bottom of the same page and click on Advertisement Search).

**We encourage all vendors to regularly check this site.**

State of Florida  
Department of Transportation  
Florida's Turnpike Enterprise  
Contractual Services Office  
P.O. Box 613069  
Ocoee, Florida 34761-3069

## INVITATION TO BID REGISTRATION

\*\*\*\*\*

**PLEASE COMPLETE AND RETURN THIS FORM ASAP**

**TO [Amanda.Cruz@dot.state.fl.us](mailto:Amanda.Cruz@dot.state.fl.us) OR FAX TO 407-264-3058 Attn: Amanda Cruz.**

\*\*\*\*\*

**Bid Number:** DOT-ITB-20-8025-AC

**Title:** GENERATOR, FUEL TANK AND AUTOMATIC TRANSFER SWITCH (ATS) REPLACEMENT AT MID- BAY BRIDGE ADMINISTRATION BUILDING, SR 293, MILEPOST 5.0

**Bid Due Date & Time (On or Before):** February 28, 2020 at 2:30pm

Potential bidders should notify our office by returning this Bid Registration Form as soon as possible after downloading. Complete the information below and fax or e-mail *this sheet only* to the Florida Department of Transportation Procurement Office at 407-264-3058, or e-mail to [amanda.cruz@dot.state.fl.us](mailto:amanda.cruz@dot.state.fl.us)

**THE INVITATION TO BID DOCUMENT YOU RECEIVED IS SUBJECT TO CHANGE. Notice of changes (Addenda), will be posted on the Florida Vendor Bid System at:**

**[http://www.myflorida.com/apps/vbs/vbs\\_main\\_menu](http://www.myflorida.com/apps/vbs/vbs_main_menu)**

**Under "Vendor Bid System" Click on "Search Advertisements"**

**Click on the Drop menu for Agency and Select "Department of Transportation"**

**Scroll down and Click on "Advertisement Search"**

**Locate the "ITB" number.**

**It is the responsibility of all potential bidders to monitor this site for any changing information prior to submitting your bid.**

Company Name: \_\_\_\_\_

Address: \_\_\_\_\_

City, State, Zip: \_\_\_\_\_

Telephone: \_\_\_\_\_ Fax Number: \_\_\_\_\_

Contact Person: \_\_\_\_\_

Internet E-Mail Address: \_\_\_\_\_

For further information on this process, e-mail or telephone: Amanda Cruz at [amanda.cruz@dot.state.fl.us](mailto:amanda.cruz@dot.state.fl.us) or (407-264-3411)

**FLORIDA DEPARTMENT  
OF TRANSPORTATION**



**TABLE OF CONTENTS**

**DOT-ITB-20-8025-AC**

**GENERATOR, FUEL TANK AND AUTOMATIC TRANSFER SWITCH (ATS) REPLACEMENT  
AT MID-BAY BRIDGE ADMINISTRATION BUILDING, SR 293, MILEPOST 5.0**

**FPID: 413878-1-93-11**

## Table of Contents

<b><u>ITEM</u></b>	<b><u>PAGE NO.</u></b>
Cover Sheet	
Advertisement .....	1 - 3
Bid Registration .....	1
Table of Contents .....	TOC 1
Invitation to Bid Instructions (Special Conditions) .....	SC-1 – SC-11
Forms .....	FORMS 1 – 7
Standard Written Agreement .....	1 – 7
Exhibit “A,” Scope of Services.....	A-1 – A-8
Attachments .....	A – C
Exhibit “B,” Method of Compensation.....	B-1 – B-2
Exhibit “C,” Bid Blank .....	C-1 – C-2

**FLORIDA DEPARTMENT  
OF  
TRANSPORTATION**



**Invitation to Bid**

**DOT-ITB-20-8025-AC**

**GENERATOR, FUEL TANK AND AUTOMATIC TRANSFER SWITCH (ATS) REPLACEMENT  
AT MID-BAY BRIDGE ADMINISTRATION BUILDING, SR 293, MILEPOST 5.0**

**FPID: 413878-1-93-11**

**MAIL BIDS, ADMINISTRATIVE  
AND TECHNICAL QUESTIONS TO:**

**Amanda Cruz, Procurement Agent  
Florida Department of Transportation  
Florida's Turnpike Enterprise  
P.O. Box 613069  
Ocoee, Florida 34761-3069  
Phone (407) 264-3411  
Fax: (407) 264-3058  
Email: [Amanda.Cruz@dot.state.fl.us](mailto:Amanda.Cruz@dot.state.fl.us)**

**SUBMIT SEALED BIDS VIA OVERNIGHT MAIL OR HAND DELIVERY TO:**

**Florida Department of Transportation, Florida's Turnpike Headquarters  
Florida's Turnpike, M.P. 263.0  
Turkey Lake Service Plaza, Bldg. 5315  
Ocoee, Florida 34761  
Attn: Amanda Cruz, Procurement Agent**



# INTRODUCTION SECTION

## 1) INVITATION

The State of Florida Department of Transportation, Florida's Turnpike Enterprise (hereinafter referred to as the "Department") is soliciting written bids from qualified bidders to establish a contract to provide all labor, materials, equipment, and incidentals necessary to perform the replacement of existing emergency standby generator, fuel tank and automatic transfer switch (ATS) including providing temporary portable emergency standby generator at Mid-Bay Bridge Administration Building. It is anticipated that a Notice to Proceed will be issued within sixty (60) calendar days after Contract execution, and the work shall be completed within sixty (60) calendar days thereafter.

For the purpose of this document, the term "bidder" means the bidder acting on its own behalf and those individuals, partnerships, firms, or corporations comprising the bidder's team. The term "bid package" means the complete response of the bidder to the Invitation to Bid including properly completed forms and supporting documentation. After the award, said bidder will be referred to as the "Vendor."

## 2) TIMELINE

Provided below is a list of critical dates and actions. These dates are subject to change. Notices of changes (Addenda) will be posted on the Florida Vendor Bid System at [http://www.myflorida.com/apps/vbs/vbs\\_main\\_menu](http://www.myflorida.com/apps/vbs/vbs_main_menu) (click on "Search Advertisements," click on the drop-down arrow beside the box under Agency, select DEPARTMENT OF TRANSPORTATION, then go to the bottom of the same page and click on Advertisement Search) under this bid number. It is the responsibility of all potential bidders to monitor this site for any changing information prior to submitting a bid.

<u>ACTION / LOCATION</u>	<u>DATE</u>	<u>LOCAL TIME</u>
<b>A PRE-BID CONFERENCE WILL NOT BE HELD</b>		
<b>DEADLINE FOR TECHNICAL QUESTIONS</b> Via email to <a href="mailto:Amanda.Cruz@dot.state.fl.us">Amanda.Cruz@dot.state.fl.us</a> Reference DOT-ITB-20-8025-AC in the subject box. There is no deadline for administrative questions.	<b>02-21-2020</b>	<b>5:00 PM</b>
<b>BIDS DUE (ON OR BEFORE)/ PUBLIC OPENING</b> Florida Turnpike Headquarters Florida Turnpike M.P. 263.0 Turkey Lake Service Plaza, Bldg. 5315 Ocoee, Florida 34761 Room 2167 (See Note 1 & 2)	<b>02-28-2020</b>	<b>2:30 PM</b>
<b>POSTING OF INTENDED DECISION/AWARD</b> Internet's Vendor Bid System	<b>03-09-2020</b>  <b>03-12-2020</b>	<b>5:00 PM</b>  <b>through</b> <b>5:00 PM</b>

(Note 1: All meetings listed above are open to the public).

(Note 2: It is the bidder's responsibility to assure that the bid is delivered to the proper place on or before the bid due date and time. Bids which for any reason are not so delivered will not be considered).

## 3) BID OPENING AGENDA

The sealed bids will be opened by the Department's Procurement Office personnel at the date, time and location referenced in the Timeline. All bid openings are open to the public and will be conducted according to the following agenda:

Opening remarks – By Department Procurement Office personnel. (Approximately two (2) minutes).

Public input period – Public input related to the bid solicitation. (Maximum of fifteen (15) minutes total)

Bids opened – At conclusion of public input or fifteen (15) minutes, whichever occurs first, timely bids received will be opened with bidder's name and prices to be read aloud.

Adjourn - After all bids received timely have been opened, the meeting will be adjourned.

#### 4) SPECIAL ACCOMMODATIONS

Any person with a qualified disability requiring special accommodations at a pre-bid conference, public meeting, and/or opening shall contact the Procurement Agent at the phone number, e-mail address or fax number provided on the title page at least five (5) working days prior to the event. Hearing or speech impaired individuals may contact this office by using the Florida Relay Services which can be reached at 1 (800) 955-8771 (TDD).

## SPECIAL CONDITIONS

#### 1) MYFLORIDAMARKETPLACE

BIDDERS MUST BE REGISTERED IN THE STATE OF FLORIDA'S MYFLORIDAMARKETPLACE SYSTEM BY THE TIME AND DATE OF THE BID OPENING OR THEY MAY BE CONSIDERED NON-RESPONSIVE (see Special Condition 21). All prospective bidders that are not registered should go to <https://vendor.myfloridamarketplace.com/> to complete on-line registration, or call 1-866-352-3776 for assisted registration.

All payment(s) to the Vendor resulting from this competitive solicitation WILL be subject to the MFMP Transaction Fee in accordance with the referenced Form PUR 1000 General Contract Condition #14. The Transaction Fee imposed shall be based upon the date of issuance of the payment.

#### 2) FLORIDA DEPARTMENT OF FINANCIAL SERVICES (DFS) W-9 REQUIREMENT

The Florida Department of Financial Services (DFS) requires all vendors that do business with the state to submit an electronic Substitute Form W-9. Vendors must submit their W-9 forms electronically at <https://flvendor.myfloridacfo.com> to receive payments from the state. Contact the DFS Customer Service Desk at (850) 413-5519 or [FLW9@myfloridacfo.com](mailto:FLW9@myfloridacfo.com) with any questions.

#### 3) QUESTIONS & ANSWERS

In accordance with Section 287.057(23), Florida Statutes, respondents to this solicitation or persons acting on their behalf may not contact, between the release of the solicitation and the end of the seventy-two (72)-hour period following the agency posting the notice of intended award, excluding Saturdays, Sundays, and state holidays, any employee or officer of the executive or legislative branch concerning any aspect of this solicitation, except in writing to the Procurement Agent or as provided in the solicitation documents. Violation of this provision may be grounds for rejecting a response.

Any technical questions arising from this Invitation to Bid must be forwarded, in writing, to the Procurement Agent identified below. Questions must be received no later than the time and date reflected in the Timeline. The Department's written response to written inquiries submitted timely by bidders will be posted on the Florida Vendor Bid System at [http://www.myflorida.com/apps/vbs/vbs\\_main\\_menu](http://www.myflorida.com/apps/vbs/vbs_main_menu) (click on "Search Advertisements," click on the drop-down arrow beside the box under Agency, select DEPARTMENT OF TRANSPORTATION, then go to the bottom of the same page and click on Advertisement Search), under this bid number. It is the responsibility of all potential bidders to monitor this site for any changing information prior to submitting a bid.

**WRITTEN TECHNICAL QUESTIONS** should be submitted to: **Amanda Cruz**, [Amanda.Cruz@dot.state.fl.us](mailto:Amanda.Cruz@dot.state.fl.us), Florida's Turnpike Headquarters, Florida's Turnpike, M.P. 263, Turkey Lake Service Plaza, Bldg. 5315, Ocoee, Florida 34761.

Questions regarding administrative aspects of the bid process should be directed to the Procurement Agent in writing at the address above or by phone: (407) 264-3411.

#### 4) ORAL INSTRUCTIONS/CHANGES TO THE INVITATION TO BID (ADDENDA)

No negotiations, decisions, or actions will be initiated or executed by a bidder as a result of any oral discussions with a state employee. Only those communications which are in writing from the Department will be considered as a duly authorized expression on behalf of the Department.

Notices of changes (Addenda) will be posted on the Florida Vendor Bid System at

[http://www.myflorida.com/apps/vbs/vbs\\_www.main\\_menu](http://www.myflorida.com/apps/vbs/vbs_www.main_menu) (click on "Search Advertisements," click on the drop-down arrow beside the box under Agency, select DEPARTMENT OF TRANSPORTATION, then go to the bottom of the same page and click on Advertisement Search) under this bid number. It is the responsibility of all potential bidders to monitor this site for any changing information prior to submitting a bid. All Addenda will be acknowledged by the Addenda Acknowledgement Form included herein and shall be submitted with the vendor's bid package.

**5) DIVERSITY ACHIEVEMENT**

**MINORITY BUSINESS ENTERPRISE (MBE) UTILIZATION**

The Department, in accordance with Title VI of the Civil Rights Act of 1964, 42 USC 2000d- 2000d-4, Title 49, Code of Federal Regulations, U.S. Department of Transportation, Subtitle A, Office of the Secretary, Part 21, Nondiscrimination in federally-assisted programs of the Department of Transportation issued pursuant to such Act, hereby notifies all bidders that the Department will affirmatively ensure that in any contract entered into pursuant to this advertisement, minority and disadvantaged business enterprises will be afforded the full opportunity to submit bids in response to this invitation and will not be discriminated on the basis of race, color, national origin, or sex in consideration for an award.

The Department encourages small, minority, women, and service-disabled veteran businesses to compete for Department contracts, both as "Vendor" and as sub-vendors. The Department, its vendors, suppliers, and consultants should take all necessary and reasonable steps to ensure that such businesses have the opportunity to compete for and perform contract work for the Department in a nondiscriminatory environment. Bidders are requested to indicate their intention regarding MBE participation on the MBE Planned Utilization Form and to submit the completed form with their bid package. The Contract Vendor will be asked to submit payment certification for MBE subcontractors used.

To request certification or to locate certified MBEs, call the Office of Supplier Diversity, Department of Management Services at (850) 487-0915, or access their MBE directory on the Internet at [www.osd.dms.state.fl.us/](http://www.osd.dms.state.fl.us/).

**6) SCOPE OF SERVICES**

Details of the services, information and items to be furnished by the Vendor are described in Exhibit "A," Scope of Services, attached hereto and made a part hereof.

**7) INTENDED AWARD**

The Department intends to award this Contract to the responsive and responsible bidder that submits the lowest responsive bid. If the Department is confronted with identical pricing or scoring from multiple vendors, the Department shall determine the order of award using the following criteria, in the order of preference listed below (from highest priority to lowest priority):

1. Section 295.187(4), Florida Statutes; Veteran Business Enterprise
2. Section 287.087, Florida Statutes; Drug Free Work Place
3. Section 287.057(11), Florida Statutes; Minority Business Enterprise

In the event that the application of the above referenced preferences does not resolve the identical replies, the Department shall determine the award by means of random drawing.

**8) MANDATORY PRE-BID CONFERENCE:**

A PRE-BID CONFERENCE WILL NOT BE HELD.

**9) QUALIFICATIONS**

**9.1 GENERAL**

Vendor must meet the following minimum qualifications:

- 9.1.1 Been actively engaged in the type of business being requested for a minimum of three (3) years.

The Vendor shall maintain and keep in force throughout the life of the Contract, renewals, and extensions, the requirements specified below. Failure of the Vendor to comply with these requirements will be sufficient grounds for the Department to declare the Vendor in accordance with the terms of Section 6; Termination and Default, of the Standard Written Agreement.

- Certification and Registration

The Vendor providing services shall hold and keep in force during the term of the Contract, a valid and current certificate/license, in accordance with the laws of the State of Florida, authorizing the Vendor, or approved sub-vendor, to perform the specified work and have all required federal, state, and local licenses and permits. A copy of all required licenses and/or certifications for this Contract shall be submitted and included with the Vendor's bid package.

All sub-vendors shall be properly licensed meeting the requirements under the respective trade category for the work to be performed under this Contract.

- Business Location

The Vendor shall have a current and valid Business Tax Receipt which states the name of the Vendor, street address of the business where all the work covered under the Contract will be handled, and the type of work that the Business Tax Receipt is issued for (which must be for the same type of services required in the Contract). If awarded the Contract, the Vendor shall be required to provide the Department verification of a Business Tax Receipt in the county the services are being provided (Okaloosa) at the Pre-work Conference.

- Certification of Experience

The organized business enterprise (e.g. corporation, LLC or sole proprietorship) shall have been licensed and actively involved in the type of business requested in the scope of work for this Contract for a minimum of three (3) years. The Vendor shall submit documentation of the work experience with its bid package.

- Performance Bond

Prior to commencement of any services pursuant to this Contract and at all times during the term hereof, including renewals and extensions, the Vendor will supply to the Department and keep in force a bond provided by a surety company authorized to do business in the State of Florida, payable to the Department and conditioned for the prompt, faithful, and efficient performance of this Contract according to the terms and conditions hereof and within the time periods specified herein, and for the prompt payment of all persons furnishing labor, materials, equipment, and supplies therefore.

The bidder must submit, with its bid, a current letter from a surety company or bonding agent authorized to do business in the State of Florida and written on company letterhead, to document the bidder's present ability to obtain a Performance Bond in the full amount of the bid. Failure by the bidder to provide this letter with its bid will constitute a non-responsive determination for its bid.

The Department will review carefully to determine the Vendor is responsive, responsible, and qualified in the area of work contemplated by the Contract.

## 9.2 BIDDER QUALIFICATIONS

When submitting a bid, each bidder must submit a written statement ("Minimum Qualifications Statement" Form 1), detailing the qualifications that demonstrate the minimum qualifications contained herein are met. Failure by the bidder to provide the above item(s) may constitute a non-responsive determination. Bids found to be non-responsive will not be considered.

9.3 AUTHORIZED TO DO BUSINESS IN THE STATE OF FLORIDA

In accordance with Sections 607.1501, 605.0211(2)(b), and 620.9102, Florida Statutes, out of state corporations, out of state limited liability companies, and out of state limited partnerships must be authorized to do business in the State of Florida. Such authorization should be obtained by the bid due date and time, but in any case, must be obtained prior to the award of the Contract. For authorization, contact:

Florida Department of State  
Tallahassee, Florida 32399  
(850) 245-6051

9.4 LICENSE TO CONDUCT SERVICES IN THE STATE OF FLORIDA

If the services being provided require that individuals be licensed by the Department of Business and Professional Regulation, such licenses should be obtained by the bid due date and time, but in any case, must be obtained prior to posting of the intended award of the Contract. For licensing, contact:

Florida Department of Business and Professional Regulation  
Tallahassee, Florida 32399  
(850) 487-1395

10) WARRANTY/SUBSTITUTIONS

When performance of the services requires the supply of commodities, a warranty is required on all items provided against defective materials, workmanship, and failure to perform in accordance with required industry performance criteria for a period of not less than ninety (90) days from the date of acceptance by the purchaser. Any deviation from this criterion must be documented in the bid response or the above statement shall prevail. Delivery of substitute commodities requires prior written approval from the ordering location.

Replacement of all materials found defective within the warranty period shall be made without cost to the purchaser, including transportation if applicable. All fees associated with restocking cancelled orders shall be the responsibility of the Vendor.

All items provided during the performance of the Contract found to be poorly manufactured will not be accepted, but returned to the Vendor, at their expense, for replacement. Replacement of all items found defective shall be made without cost to the Department, including transportation, if applicable. As it may be impossible for each facility to inspect all items upon arrival, a reasonable opportunity must be given to these facilities for inspection of the items and returning those items that are defective.

11) LIABILITY INSURANCE

The Vendor shall not commence any work until they have obtained the following types of insurance, and certificates of such insurance have been received by the Department. Nor shall the Vendor allow any sub-vendor to commence work on this project until all similar insurance required of the sub-vendor has been so obtained. The Vendor shall submit the required Certificates of Insurance to the **Florida Department of Transportation, Procurement Office, Amanda Cruz, Florida's Turnpike Headquarters, Florida's Turnpike M.P. 263.0, Turkey Lake Service Plaza, Bldg. 5315, Ocoee, Florida 34761** within ten (10) days after the ending date of the period for posting the intended award decision.

The Vendor must carry and keep in force during the period of this Contract a general liability insurance policy or policies with a company authorized to do business in the State of Florida, affording public liability insurance with combined bodily injury limits of at least \$200,000 minimum per person and \$300,000 minimum each occurrence, and property damage insurance of at least \$200,000 minimum each occurrence, for the services to be rendered in accordance with this Contract.

**WORKERS' COMPENSATION.** The Vendor shall also carry and keep in force Workers' Compensation insurance as required for the State of Florida under the Workers' Compensation Law.

With respect to any general liability insurance policy required pursuant to this Agreement, all such policies shall be issued by companies licensed to do business in the State of Florida. The Vendor shall provide to the Department certificates showing the required coverage to be in effect with endorsements showing the Department to be an additional insured prior to commencing any work under this Contract. The certificates and policies shall provide that in the event of any material change in or cancellation of the policies reflecting the required coverage, thirty days advance notice shall be given to the Department or as provided in accordance with Florida law.

The Department shall be exempt from, and in no way liable for, any sums of money which may represent a deductible in any insurance policy. The payment of such deductible shall be the sole responsibility of the Vendor or subcontractor providing such insurance. Policies that include Self Insured Retention (SIR) will not be accepted.

**12) PERFORMANCE BOND**

The intended award bidder shall provide the Department with a Performance Bond in the “full amount of the bid.” The Performance Bond shall be provided by a surety company authorized to do business in the State of Florida. The Performance Bond shall be executed and furnished to the Department prior to Contract execution and no later than ten (10) days after the ending date of the period for posting the intended award decision, unless the Department extends the time period in writing. Failure to provide the required Performance Bond (Form 375-040-27) to the Department within the aforementioned timeframe will void the Intended Award’s bid and the Department will proceed in contracting with the next lowest responsive bidder.

The bidder must submit, with its bid, a current letter from a surety company or bonding agent authorized to do business in the State of Florida and written on company letterhead, to document the bidder’s present ability to obtain a Performance Bond in the “full amount of the bid.” Failure by the bidder to provide this letter with its bid will constitute a non-responsive determination for its bid. Bids found to be non-responsive will not be considered.

**13) METHOD OF COMPENSATION**

View Exhibit “B,” Method of Compensation

**14) CONTRACT DOCUMENT**

**STANDARD WRITTEN AGREEMENT**

The Department’s “Standard Written Agreement” is attached hereto and made a part hereof. The terms and conditions contained therein will become an integral part of the Contract resulting from this solicitation. In submitting a bid, the bidder agrees to be legally bound by these terms and conditions.

**15) REVIEW OF BIDDER'S FACILITIES & QUALIFICATIONS**

After the bid due date and prior to Contract execution, the Department reserves the right to perform or to have performed, an on-site review of the bidder's facilities and qualifications. This review will serve to verify data and representations submitted by the bidder and may be used to determine whether the bidder has adequate facilities, equipment, qualified and experienced staff, and overall management capabilities to provide the required services. The review may also serve to verify whether the bidder has financial capabilities adequate to meet the Contract requirements.

**Should** the Department determine that the bid package has material misrepresentations or that the size or nature of the bidder's facilities, equipment, management capabilities, or the number of experienced personnel (including technical staff) are not adequate to ensure satisfactory contract performance, the Department has the right to reject the bid.

**16) PROTEST OF INVITATION TO BID SPECIFICATIONS**

Any person who is adversely affected by the contents of this Invitation to Bid must file the following with the Department of Transportation, Clerk of Agency Proceedings, Office of the General Counsel, 605 Suwannee Street, Mail Station 58, Tallahassee, Florida 32399-0450:

1. A written notice of protest within seventy-two (72) hours after the posting of the solicitation, (the notice of protest may be Faxed to 850-414-5264), and
2. A formal written protest in compliance with Section 120.57(3), Florida Statutes, within ten (10) days of the date on which the written notice of protest is filed.

Failure to file a protest within the time prescribed in Section 120.57(3), Florida Statutes, or failure to post the bond or other security required by law within the time allowed for filing a bond shall constitute a waiver of proceedings under Chapter 120, Florida Statutes.

**17) UNAUTHORIZED ALIENS**

The employment of unauthorized aliens by any Vendor is considered a violation of Section 274A(e) of the Immigration and Nationality Act. If the Vendor knowingly employs unauthorized aliens, such violation shall be cause for unilateral cancellation of the Contract.

**18) SCRUTINIZED COMPANIES LISTS**

All Responses, regardless of dollar value, must include a completed [Vendor Certification Regarding Scrutinized Companies Lists](#) to certify the respondent is not on either of those lists. The form should be submitted with the Bid Blank.

A Vendor is ineligible to enter into a contract with the Department for goods or services of any amount if, at the time of entering into such contract, the Vendor is on the Scrutinized Companies that Boycott Israel List, created pursuant to Section 215.4725, Florida Statutes, or is engaged in a boycott of Israel.

Section 287.135, Florida Statutes, also prohibits companies from entering into a contract for goods or services of \$1 million or more that are on either the Scrutinized Companies with Activities in Sudan List or the Scrutinized Companies with Activities in the Iran Petroleum Energy Sector Lists which were created pursuant to Section 215.473, Florida Statutes.

If the Department determines the Vendor submitted a false certification under Section 287.135 of the Florida Statutes, the Department shall either terminate the Contract after it has given the Vendor notice and an opportunity to demonstrate the Department's determination of false certification was in error pursuant to Section 287.135 of the Florida Statutes, or maintain the Contract if the conditions of Section 287.135 of the Florida Statutes are met.

**19) RESERVATIONS**

The Department reserves the right to accept or reject any or all bids received and reserves the right to make an award without further discussion of the bids submitted. Therefore, the bidder should make sure that the bid package submitted is complete and accurate and submitted to ensure delivery on or before the bid opening time and date specified in this solicitation. It is understood that the bid will become a part of the Department's official file, without obligation to the Department.

**20) ADDITIONAL TERMS & CONDITIONS**

No conditions may be applied to any aspect of the ITB by the bidder. Any conditions placed on any aspect of the bid documents by the bidder may result in the bid being rejected as a conditional bid (see "RESPONSIVENESS OF BIDS"). **DO NOT WRITE IN CHANGES ON ANY ITB SHEET**. The only recognized changes to the ITB prior to bid opening will be a written Addenda issued by the Department.

**21) RESPONSIVENESS OF BIDS**

Bids will not be considered if not received by the Department on or before the date and time specified as the due date for submission. All bids must be typed or printed in ink. A responsive bid is an offer to provide the services specified in this Invitation to Bid in accordance with all requirements of this Invitation to Bid. Bids found to be non-responsive will not be considered. Bids may be rejected if found to be irregular or not in conformance with the requirements and instructions herein contained. A bid may be found to be irregular or non-responsive by reasons that include, but are not limited to, failure to utilize or complete prescribed forms, modifying the bid requirements, submitting conditional bids or incomplete bids, submitting indefinite or ambiguous bids, or executing forms or the bid sheet with improper and/or undated signatures. Other conditions which may cause rejection of bids include, evidence of collusion among bidders, obvious lack of experience or expertise to provide the required services, and failure to perform or meet financial obligations on previous contracts. All determinations of responsiveness will be the responsibility of the Department.

**22) BID BLANK**

The bidder must use the attached Bid Blank to submit its bid. The Bid Blank must be signed and dated in ink by a representative who is authorized to contractually bind the bidder. All bid blanks and other documentation submitted in response to this solicitation must be executed and submitted in a sealed envelope. **Indicate the bid number, with the time and date of the bid opening, on the envelope used to return the bid.**

**23) "DRUG-FREE WORK PLACE" PREFERENCE**

Whenever two (2) or more bids which are equal with respect to price, quality, and service are received, the Department shall determine the order of award first in accordance with Section 295.187(4), Florida Statutes, giving preference to "Veteran Business Enterprise" then to bid responses from vendors that certify the business has implemented a drug-free workplace program in accordance with Section 287.087, Florida Statutes. The "Drug-Free Workplace Program Certification" must be completed and submitted with the bid response to be eligible for this preference.

**24) COPYRIGHTED MATERIAL**

Copyrighted material will be accepted as part of a bid only if accompanied by a waiver that will allow the Department to make paper and electronic copies necessary for the use of Department staff and agents. It is noted that copyrighted material is not exempt from the Public Records Law, Chapter 119, Florida Statutes. Therefore, such material will be subject to viewing by the public, but copies of the material will not be provided to the public.

**25) ATTACHMENT TO ITB SUBMITTAL - CONFIDENTIAL MATERIAL**

The bidder must include any materials it asserts to be exempted from public disclosure under Chapter 119, Florida Statutes, in a separate bound document labeled "Attachment to Invitation to Bid, Number DOT-ITB-20-8025-AC-Confidential Material." The bidder must identify the specific Statute that authorizes exemption from the Public Records Law. Any claim of confidentiality on materials the bidder asserts to be exempt from public disclosure and placed elsewhere in the bid will be considered waived by the bidder upon submission, effective after opening.

**26) MAIL OR DELIVER BIDS TO: (DO NOT FAX OR SEND BY E-MAIL)**

**OVERNIGHT MAIL OR HAND DELIVERY**

**Florida Department of Transportation  
Florida's Turnpike Enterprise  
Mrs. Amanda Cruz  
Florida's Turnpike, Mile Post 263  
Turkey Lake Service Plaza, Bldg. 5315  
Ocoee, Florida 34761-3069**

**UNITED STATES POSTAL SERVICE (USPS)**

**Florida Department of Transportation  
Florida's Turnpike Enterprise  
Mrs. Amanda Cruz  
P.O. Box 613069  
Ocoee, Florida 34761-3069**

It is the bidder's responsibility to assure that the bid is delivered to the proper place **on or before** the bid due date and time (See Introduction Section 2 Timeline). Bids which for any reason are not so delivered, will not be considered. The Department receives two (2) United Parcel Service (UPS) deliveries per weekday. EXPRESS/FIRST OVERNIGHT delivered packages will be received in the morning, and UPS Ground delivered packages will be received by the end of the day. Please check each carrier for exact delivery times to ensure bid packages are received on or before the bid due date and time.

**27) MODIFICATIONS, RESUBMITTAL AND WITHDRAWAL**

Bidders may modify submitted bids at any time prior to the bid due date. Requests for modification of a submitted bid shall be in writing and must be signed by an authorized signatory of the bidder. Upon receipt and acceptance of such a request, the entire bid will be returned to the bidder and not considered unless resubmitted by the due date and time. Bidders may also send a change in a sealed envelope to be opened at the same time as the bid. The ITB number, opening date and time should appear on the envelope of the modified bid.



**28) POSTING OF INTENDED DECISION/AWARD**

**28.1 General:**

The Department's decision will be posted on the Florida Vendor Bid System, [http://www.myflorida.com/apps/vbs/vbs\\_main\\_menu](http://www.myflorida.com/apps/vbs/vbs_main_menu) (click on "Search Advertisements," click on the drop-down arrow beside the box under Agency, select DEPARTMENT OF TRANSPORTATION, then go to the bottom of the same page and click on Advertisement Search) on date and time in the Timeline, and will remain posted for a period of seventy-two (72) hours. Any bidder who is adversely affected by the Department's recommended award or intended decision must file the following with the Department of Transportation, Clerk of Agency Proceedings, Office of the General Counsel, 605 Suwannee Street, Mail Station 58, Tallahassee, Florida 32399-0450:

1. A written notice of protest within seventy-two (72) hours after posting of the Intended Award, (the notice of protest may be faxed to 850-414-5264), and;
2. A formal written protest and protest bond in compliance with Section 120.57(3), Florida Statutes, within ten (10) days of the date on which the written notice of protest is filed. At the time of filing the formal written protest, a bond (a cashier's check or money order may be accepted) payable to the Department must also be submitted in an amount equal to one percent (1%) of the estimated contract amount based on the contract price submitted by the protestor.

Failure to file a protest within the time prescribed in Section 120.57(3), Florida Statutes, or failure to post the bond or other security required by law within the time allowed for filing a bond shall constitute a waiver of proceedings under Chapter 120, Florida Statutes.

**28.2 Inability to Post:**

If the Department is unable to post as defined above, the Department will notify all bidders by electronic notification on the Florida Vendor Bid System (see Special Condition 28.1, above) or by mail, fax, and/or telephone. The Department will provide notification of any future posting in a timely manner.

**28.3 Request to Withdraw Bid:**

Requests for withdrawal will be considered if received by the Department, in writing, within seventy-two (72) hours after the bid opening time and date. Requests received in accordance with this provision will be granted by the Department upon proof of the impossibility to perform based upon obvious error on the part of the bidder. Bidders that do not withdraw as stated above will forfeit their bid bond, if applicable.

**29) AWARD OF THE CONTRACT**

Services will be authorized to begin when the Vendor receives the following document(s), as appropriate, indicating the encumbrance of funds and award of the Contract:

- a) A Standard Written Agreement executed by both parties.

**30) RENEWAL**

Upon mutual agreement, the Department and the Contract Vendor may renew the Contract for a period that may not exceed three (3) years or the term of the Original Contract, whichever is longer. The renewal must be in writing and signed by both parties, and is subject to the same terms and conditions set forth in the initial Contract and any written amendments signed by the parties. Any renewal shall specify the renewal price, as set forth in the solicitation response except that an agency may negotiate lower pricing. The renewal is contingent upon satisfactory performance evaluations and subject to the availability of funds.

**31) ATTACHED FORMS**

- Form 1 – Certification of Experience Documentation
- Form 2 – Drug Free Workplace Program Certification
- Form 3 – Contractor Notification Form
- Form 4 – Scrutinized Companies Lists, 375-030-60
- Form 5 – Corporate Resolution
- Form 6 – Addendum Acknowledgement Form
- Form 7 – Performance Bond Form, 375-040-27

**32) TERMS AND CONDITIONS**

32.1 General Contract Conditions (PUR 1000)

The State of Florida’s General Contract Conditions are outlined in form PUR 1000, which is a downloadable document incorporated into this Invitation to Bid (ITB) by reference. Any terms and conditions set forth in this ITB document take precedence over the PUR 1000 form where applicable.

<http://www.dms.myflorida.com/content/download/2933/11777/1000.pdf>

The following paragraphs do not apply to this Invitation to Bid:

- Paragraph 31, Dispute Resolution - PUR 1000
- Paragraph 40, PRIDE – PUR 1000, when federal funds are utilized.

32.2 General Instructions to Respondents (PUR 1001)

The State of Florida’s General Instructions to Respondents are outlined in form PUR 1001, which is a downloadable document incorporated into this Invitation to Bid (ITB) by reference. Any terms and conditions set forth in this ITB document take precedence over the PUR 1001 form where applicable.

<http://www.dms.myflorida.com/content/download/2934/11780/1001.pdf>

The following paragraphs do not apply to this Invitation to Bid:

- Paragraph 3, Electronic Submission – PUR 1001
- Paragraph 4, Terms and Conditions – PUR 1001
- Paragraph 5, Questions – PUR 1001

**33) ORDER OF PRECEDENCE**

All responses are subject to the terms and conditions of this solicitation, which, in case of conflict, shall have the following order of precedence listed:

- Standard Written Agreement
- Exhibit “A,” Scope of Services
- Attachments
- Special Conditions
- Exhibit “B,” Method of Compensation
- Exhibit “C,” Bid Blank
- Instructions to Respondents (PUR 1001)
- General Conditions (PUR 1000)

**FLORIDA DEPARTMENT  
OF TRANSPORTATION**



**FORMS**

**DOT-ITB-20-8025-AC**

**GENERATOR, FUEL TANK AND AUTOMATIC TRANSFER SWITCH (ATS) REPLACEMENT  
AT MID-BAY BRIDGE ADMINISTRATION BUILDING, SR 293, MILEPOST 5.0**

**FPID: 413878-1-93-11**

### CERTIFICATION OF EXPERIENCE DOCUMENTATION

I, \_\_\_\_\_, \_\_\_\_\_, of  
(Print/Type Name) (Title)

\_\_\_\_\_, hereby certify that this Company has been in business  
(Name of Business)

for a minimum of the past 3 years and has the experience to perform the services requested by DOT-ITB-20-8025-AC.

As I have indicated experience above, I now submit the following list of business and client references that will attest to our services and business relationships for the periods indicated and I hereby give permission to the Department to inquire for references as to my performance.

Signature: \_\_\_\_\_ Date: \_\_\_\_\_

Name of Business: \_\_\_\_\_

The Department will review carefully to determine if the Vendor(s) is responsive, responsible and qualified in the area of work contemplated by this Contract.

Describe your work experience in detail for the minimum period required, beginning with your current or most recent project. Use a separate block to describe each project. (Print out additional copies of the form or attach additional sheets as necessary.)

Date: (Mo. & Yr.): From \_\_\_\_\_ To \_\_\_\_\_ Dollar Value of Project: \$ \_\_\_\_\_

Client Name: \_\_\_\_\_ Client's Project Manager: \_\_\_\_\_

Address: \_\_\_\_\_ City: \_\_\_\_\_

State: \_\_\_\_\_ Zip: \_\_\_\_\_ Phone: ( ) \_\_\_\_\_ - \_\_\_\_\_ Fax: ( ) \_\_\_\_\_ - \_\_\_\_\_

Project Description: \_\_\_\_\_

Date: (Mo. & Yr.): From \_\_\_\_\_ To \_\_\_\_\_ Dollar Value of Project: \$ \_\_\_\_\_

Client Name: \_\_\_\_\_ Client's Project Manager: \_\_\_\_\_

Address: \_\_\_\_\_ City: \_\_\_\_\_

State: \_\_\_\_\_ Zip: \_\_\_\_\_ Phone: ( ) \_\_\_\_\_ - \_\_\_\_\_ Fax: ( ) \_\_\_\_\_ - \_\_\_\_\_

Project Description: \_\_\_\_\_

Date: (Mo. & Yr.): From \_\_\_\_\_ To \_\_\_\_\_ Dollar Value of Project: \$ \_\_\_\_\_

Client Name: \_\_\_\_\_ Client's Project Manager: \_\_\_\_\_

Address: \_\_\_\_\_ City: \_\_\_\_\_

State: \_\_\_\_\_ Zip: \_\_\_\_\_ Phone: ( ) \_\_\_\_\_ - \_\_\_\_\_ Fax: ( ) \_\_\_\_\_ - \_\_\_\_\_

Project Description: \_\_\_\_\_

---

Date: (Mo. & Yr.): From \_\_\_\_\_ To \_\_\_\_\_ Dollar Value of Project: \$ \_\_\_\_\_  
Client Name: \_\_\_\_\_ Client's Project Manager: \_\_\_\_\_  
Address: \_\_\_\_\_ City: \_\_\_\_\_  
State: \_\_\_\_\_ Zip: \_\_\_\_\_ Phone: (     ) \_\_\_\_\_ - \_\_\_\_\_ Fax: (     ) - \_\_\_\_\_  
Project Description: \_\_\_\_\_

---

---

Date: (Mo. & Yr.): From \_\_\_\_\_ To \_\_\_\_\_ Dollar Value of Project: \$ \_\_\_\_\_  
Client Name: \_\_\_\_\_ Client's Project Manager: \_\_\_\_\_  
Address: \_\_\_\_\_ City: \_\_\_\_\_  
State: \_\_\_\_\_ Zip: \_\_\_\_\_ Phone: (     ) \_\_\_\_\_ - \_\_\_\_\_ Fax: (     ) - \_\_\_\_\_  
Project Description: \_\_\_\_\_

---

---

Date: (Mo. & Yr.): From \_\_\_\_\_ To \_\_\_\_\_ Dollar Value of Project: \$ \_\_\_\_\_  
Client Name: \_\_\_\_\_ Client's Project Manager: \_\_\_\_\_  
Address: \_\_\_\_\_ City: \_\_\_\_\_  
State: \_\_\_\_\_ Zip: \_\_\_\_\_ Phone: (     ) \_\_\_\_\_ - \_\_\_\_\_ Fax: (     ) - \_\_\_\_\_  
Project Description: \_\_\_\_\_

---

---

Date: (Mo. & Yr.): From \_\_\_\_\_ To \_\_\_\_\_ Dollar Value of Project: \$ \_\_\_\_\_  
Client Name: \_\_\_\_\_ Client's Project Manager: \_\_\_\_\_  
Address: \_\_\_\_\_ City: \_\_\_\_\_  
State: \_\_\_\_\_ Zip: \_\_\_\_\_ Phone: (     ) \_\_\_\_\_ - \_\_\_\_\_ Fax: (     ) - \_\_\_\_\_  
Project Description: \_\_\_\_\_

---

---

Name of Business: \_\_\_\_\_

**FORM MUST BE EXECUTED AND SUBMITTED WITH BID PACKAGE**

**DRUG-FREE WORKPLACE PROGRAM,  
 VEHICLE OPERATOR LICENSE & VEHICLE REGISTRATION,  
 NOTICE OF INTENT TO SUBLET**

I, \_\_\_\_\_, \_\_\_\_\_  
 (Name) Owner, President, Vice President or Designated Officer (Corp. Resolution\*) (Title)  
 of \_\_\_\_\_, hereby certify that;  
 (Name of Business)

**A. Drug-Free Workplace Program Certification**

This firm \_\_\_\_ (has) \_\_\_\_ (has not) implemented a Drug-Free Workplace Program in accordance with the provision of Section 287.087, Florida Statutes.

**B. Vehicle Operator License & Vehicle Registration**

All operators driving bidder vehicles are properly licensed in the State of Florida, for the type of vehicle being operated, in accordance with Chapter 322 Florida Statutes and further states that all vehicles operated, or caused to be operated by said bidder;

- Meet the financial responsibility requirements in accordance with Chapter 324 Florida Statutes and shall remain so for the duration of the Contract.
- Registered in the State of Florida, in accordance with Section 337.11 Florida Statutes and insured in the State of Florida to the limits required within the Contract and in accordance with Sections 320.02, 316.646, and 627.733 Florida Statutes and shall remain so for the duration of the Contract.

**C. Notice of Intent to Sublet**

We \_\_\_\_ (do) \_\_\_\_ (do not) intend to sublet a portion of the work on this project.

If I have indicated above that a portion of the work will be sublet, then I hereby further certify that we have taken affirmative action to seek out and consider Minority Business Enterprises as potential subcontractors and/or suppliers. The classes of work I intend to sublet and the firms considered as potential subcontractors are as follows:

<u>Class of Work</u>	<u>Potential Subcontractors</u>	<u>Percent</u>	<u>MBE (Y) or (N)</u>
_____	_____	_____ %	_____
_____	_____	_____ %	_____
_____	_____	_____ %	_____
_____	_____	_____ %	_____
_____	_____	_____ %	_____
_____	_____	_____ %	_____
_____	_____	_____ %	_____

Percentage must not be for more than 60% of the Contract total

Signature: \_\_\_\_\_ Date: \_\_\_\_\_  
 Owner, President, Vice President or Designated Officer (Corp. Resolution\*)

\*If person signing the form is someone other than the Owner, President or Vice President, a copy of the Corporate Resolution granting signature authorization must be furnished in the bid package.

**FORM MUST BE EXECUTED AND SUBMITTED WITH THE BID PACKAGE**

**CONTRACTOR NOTIFICATION**

**TO:** All Contractors  
**FROM:** Turnpike Asbestos Coordinator  
(954) 975-4855  
Pompano Beach, Florida  
**SUBJECT:** ASBESTOS-CONTAINING MATERIALS IN TURNPIKE FACILITIES

---

It is possible that you may encounter Asbestos-containing materials (ACM) while working in State-owned buildings since ACM are present in many of these buildings. The presence of ACM does not necessarily mean that a hazard exists. However, a hazard may be created when ACM is disturbed and asbestos fibers become airborne. The best way to maintain a safe environment is to avoid disturbance of ACM.

Prominently posted in each building is an "Occupant Notification" which summarizes known locations of ACM in that building. An Operations and Maintenance (O & M) plan has been developed for these known locations of ACM. Since the known locations may or may not include all ACM, workers must exercise caution and be watchful for materials that might contain asbestos. You must avoid inadvertently disturbing ACM or suspected ACM as you carry out your work.

If you need additional information regarding ACM in a particular building or would like to see a copy of the O & M Plan, contact the Building Asbestos Contact Person (BACPer) responsible for that building or the Turnpike Asbestos Coordinator. The specific designated BACPer (name and telephone) is listed on the "Occupant Notification."

If your work necessitates the disturbance of ACM, you shall take all precautions necessary to protect human health and the environment from asbestos fibers. At a minimum, you must use the procedures found in the O & M Plan; comply with all federal, state and local laws governing work with asbestos; assure that your employees are medically certified, trained and equipped with the proper personal protective devices for safe handling of ACM; and ensure that all employees performing work with ACM related to State-owned buildings execute a "Certificate of Worker's Acknowledgment" prior to beginning work. Immediately upon inadvertently or before disturbing ACM in any State-owned building you must notify the designated BACPer.

**ACKNOWLEDGMENT OF ASBESTOS WARNING**

I, \_\_\_\_\_ (Name) Owner, President, Vice President or Designated Officer (Corp. Resolution\*) \_\_\_\_\_ (Title)

of \_\_\_\_\_, hereby acknowledge receipt of the above memorandum about  
(Name of Business)

Asbestos-Containing Materials (ACM) Information for Turnpike Facilities and information on how to contact the Building Asbestos Contact Person (BACPer), for information regarding how to find out where asbestos-containing materials are located and how to avoid any contact with ACM.

Signature: \_\_\_\_\_ Date: \_\_\_\_\_  
Owner, President, Vice President or Designated Officer (Corp. Resolution\*)

\* If person signing the form is someone other than the Owner, President or Vice President, a copy of the Corporate Resolution granting signature authorization must be furnished in the bid package.

**FORM MUST BE EXECUTED AND SUBMITTED WITH THE BID PACKAGE**

STATE OF FLORIDA DEPARTMENT OF TRANSPORTATION

Florida Statutes  
287.135

**VENDOR CERTIFICATION REGARDING  
SCRUTINIZED COMPANIES LISTS**

375-030-60  
PROCUREMENT  
OGC – 07/18

Respondent Vendor Name: _____
Vendor FEIN: _____
Vendor's Authorized Representative Name and Title: _____
Address: _____
City: _____ State: _____ Zip: _____
Phone Number: _____
Email Address: _____

Section 287.135, Florida Statutes prohibits a company from bidding on, submitting a proposal for, or entering into or renewing a contract for goods or services of any amount if the company is on the Scrutinized Companies that Boycott Israel List, created pursuant to Section 215.475, Florida Statutes or is engaged in a boycott of Israel. Section 287.135, Florida Statutes also prohibits a company from bidding on, submitting a proposal for, or entering into or renewing a contract for goods or services of \$1,000,000 or more, if the company is on either the Scrutinized Companies with Activities in Sudan List, or the Scrutinized Companies with Activities in the Iran Petroleum Energy Sector Lists which are created pursuant to Section 215.473, Florida Statutes.

As the person authorized to sign on behalf of Respondent, I hereby certify that the company identified above in the section entitled "Respondent Vendor Name" is not listed on either the Scrutinized Companies with Activities in Sudan List or the Scrutinized Companies with Activities in the Iran Petroleum Energy Sector List, or the Scrutinized Companies that Boycott Israel List. I further certify that the company is not engaged in a boycott of Israel. I understand that pursuant to Section 287.135, Florida Statutes, the submission of a false certification may subject company to civil penalties, attorney's fees, and/or costs.

Certified By: _____
who is authorized to sign on behalf of the above referenced company.
Authorized Signature Print Name and Title: _____
Date: _____



**CORPORATE RESOLUTION OF**

\_\_\_\_\_  
**(recite name of Business)**

**WHEREAS**, it is in the best interests of this corporation to enter into a contract with the State of Florida, Department of Transportation for \_\_\_\_\_

\_\_\_\_\_  
**NOW THEREFORE, IT IS RESOLVED**, that \_\_\_\_\_ ( title of authorized officer; (e.g., John Doe, Regional Sales Manager) of this Business is hereby authorized and empowered on behalf of the Business to enter into a contract with the State of Florida, Department of Transportation, in consideration of \_\_\_\_\_ Dollars (\$ \_\_\_\_\_), upon the terms and conditions contained in the proposed Contract, a copy of which is attached hereto as Exhibit A, Scope of Services and made a part hereof.

**CERTIFICATE OF RESOLUTION**

I, \_\_\_\_\_, secretary of \_\_\_\_\_ (name of Business), a Florida Business, or a Business founded in the State of \_\_\_\_\_, and authorized by the Secretary of State, State of Florida, to conduct business in the State of Florida, hereby certify that the foregoing is a full, true, and correct copy of the resolution of the Board of Directors of the Business, duly and regularly passed and adopted at a meeting of the Board duly called and held in all respects as required by law, and by the bylaws of the Business, on the \_\_\_\_\_ day of \_\_\_\_\_, 20\_\_\_\_\_, at which meeting a quorum of the Board was present.

Executed by me as secretary of the corporation on this \_\_\_\_\_ day of \_\_\_\_\_, 20\_\_\_\_\_.

\_\_\_\_\_  
Signature of Secretary

\_\_\_\_\_  
Name of Secretary printed or typed

**FLORIDA DEPARTMENT OF TRANSPORTATION  
DOT-ITB-20-8025-AC**

---

**ADDENDA ACKNOWLEDGEMENT FORM**

FORM NO. 6

The Vendor shall acknowledge receipt of each addenda to this Invitation to Bid by completing this form and including in the Vendor's bid package.

<u>Addenda</u>	<u>Date</u>
_____	_____
_____	_____
_____	_____
_____	_____
_____	_____
_____	_____
_____	_____
_____	_____
_____	_____
_____	_____

Failure to confirm receipt of addenda may cause for rejection of the Vendor's bid.

Dated \_\_\_\_\_

\_\_\_\_\_  
Legal Name of Firm

By \_\_\_\_\_  
Signature

\_\_\_\_\_  
Title

NOTE: Attach additional pages as necessary

**PERFORMANCE BOND**

KNOW ALL MEN BY THESE PRESENTS: That we, \_\_\_\_\_  
(name)  
\_\_\_\_\_ (hereinafter called Vendor) of \_\_\_\_\_  
(address)

\_\_\_\_\_ and  
\_\_\_\_\_ (hereinafter called Surety) of  
(name)  
\_\_\_\_\_  
(address)

duly authorized to do business in the State of Florida, are held and firmly bound unto the State of Florida in the full and just sum of \_\_\_\_\_ Dollars (\$ \_\_\_\_\_), lawful money of the United States of America, to be paid to the Florida Department of Transportation (hereinafter called the Department), to which payment will and truly to be made we bind ourselves, our heirs, executors, administrators, successors and assigns, jointly and severally and firmly by these presents;

WHEREAS, the above Vendor has subscribed to an agreement with the Department to bear the date of \_\_\_\_\_, for contractual services agreement in connection with \_\_\_\_\_

\_\_\_\_\_ in \_\_\_\_\_ County(ies), particularly known as \_\_\_\_\_

(hereinafter called the Agreement), upon certain terms and conditions in said Agreement more particularly mentioned; and

NOW, THEREFORE, The condition of this obligation is such that if the above Vendor in all respects will comply with the terms and conditions of said Agreement, and its obligations thereunder, including the Scope of Services, Specifications, General Conditions, Special Conditions, Bid Blank therein referred to and made a part thereof, and such alterations as may be made in said conditions and specifications, as therein provided for; and, further, if such Vendor will promptly make payment to all persons supplying labor, material, equipment and supplies, used directly or indirectly by the said Vendor or any subcontractor(s) in the prosecution of the work provided for in said Agreement, and promptly will pay all State Workers' Compensation and Unemployment Compensation taxes incurred in the performance of the said Agreement and will pay to the Department any amount in money or property, the Department may lose or be overcharged or otherwise defrauded of, by reason of any wrongful or criminal act of the Vendor, its agents, or employees, then this obligation is to be void; otherwise, to be and remain in full force and virtue in law.

WITNESS the signature of the Vendor and the signature of the Surety by \_\_\_\_\_ its

(Agent or Attorney-in-Fact, or otherwise)

with seals of said Vendor and Surety hereunto affixed this \_\_\_\_\_ day of \_\_\_\_\_.

\_\_\_\_\_  
Surety  
BY: \_\_\_\_\_  
Signature  
TITLE: \_\_\_\_\_  
Attorney-in-Fact/Agent  
(Surety Seal)

Name/Telephone #: \_\_\_\_\_  
Address: \_\_\_\_\_

\_\_\_\_\_  
Vendor  
BY: \_\_\_\_\_  
Authorized Signature(s)  
TITLE: \_\_\_\_\_  
ATTEST: \_\_\_\_\_  
Secretary/Notary

BY: \_\_\_\_\_  
Signature

Note: Attach Power of Attorney showing authority of Surety's Agent or Attorney-in-Fact. This bond is not for public works contracts required by Section 25.05, Florida Statutes.

**FLORIDA DEPARTMENT  
OF TRANSPORTATION**



**STANDARD WRITTEN AGREEMENT**

**DOT-ITB-20-8025-AC**

**GENERATOR, FUEL TANK AND AUTOMATIC TRANSFER SWITCH (ATS) REPLACEMENT  
AT MID-BAY BRIDGE ADMINISTRATION BUILDING, SR 293, MILEPOST 5.0**

**FPID: 413878-1-93-11**

STATE OF FLORIDA DEPARTMENT OF TRANSPORTATION  
**STANDARD WRITTEN AGREEMENT**

Agreement No.: \_\_\_\_\_

Financial Project I.D.: 413878-1-93-11

F.E.I.D. No.: \_\_\_\_\_

Appropriation Bill Number(s)/Line Item Number(s) for 1<sup>st</sup> year of  
contract, pursuant to s. 216.313, F.S. \_\_\_\_\_  
(required for contracts in excess of \$5 million)

Procurement No.: DOT-ITB-20-8025-AC

D.M.S. Catalog Class No.: 72151505, 72101517, 26101400, 26111600, 25172400

BY THIS AGREEMENT, made and entered into this \_\_\_\_\_ day of \_\_\_\_\_, 2020, by and between the STATE OF FLORIDA DEPARTMENT OF TRANSPORTATION, hereinafter called the “Department” and \_\_\_\_\_, of \_\_\_\_\_, duly authorized to conduct business in the State of Florida, hereinafter called “Vendor,” hereby agree as follows:

1. SERVICES AND PERFORMANCE

- A. In connection with all labor, materials, equipment and incidentals necessary to perform the replacement of existing emergency standby generators, fuel tank and automatic transfer switch (ATS) including providing temporary portable emergency standby generator at Mid-Bay Bridge Administration Building and items as described in Exhibit “A,” attached hereto and made a part hereof.
- B. Before making any additions or deletions to the work described in this Agreement, and before undertaking any changes or revisions to such work, the parties shall negotiate any necessary cost changes and shall enter into an Amendment covering such work and compensation. Reference herein to this Agreement shall include any amendment(s).
- C. All tracings, plans, specifications, maps, computer files, and reports prepared or obtained under this Agreement, as well as all data collected, together with summaries and charts derived therefrom, shall be the exclusive property of the Department without restriction or limitation on their use and shall be made available, upon request, to the Department at any time during the performance of such services and/or upon completion or termination of this Agreement. Upon delivery to the Department of said document(s), the Department shall become the custodian thereof in accordance with Chapter 119, Florida Statutes. The Vendor shall not copyright any material and products or patent any invention developed under this Agreement. The Department shall have the right to visit the site for inspection of the work and the products of the Vendor at any time.
- D. All final plans, documents, reports, studies, and other data prepared by the Vendor shall bear the professional’s seal/signature, in accordance with the applicable Florida Statutes, Administrative Rules promulgated by the Department of Business and Professional Regulation, and guidelines published by the Department, in effect at the time of execution of this Agreement. In the event that changes in the statutes or rules create a conflict with the requirements of published guidelines, requirements of the statutes and rules shall take precedence.
- E. The Vendor agrees to provide project schedule progress reports in a format acceptable to the Department and at intervals established by the Department. The Department shall be entitled at all times to be advised, at its request, as to the status of work being done by the Vendor and of the details thereof. Coordination shall be maintained by the Vendor with representatives of the Department, or of other agencies interested in the project on behalf of the Department. Either party to this Agreement may request and be granted a conference.
- F. All services shall be performed by the Vendor to the satisfaction of the Director who shall decide all questions, difficulties, and disputes of any nature whatsoever that may arise under or by reason of this Agreement, the prosecution and fulfillment of the services hereunder and the character, quality, amount of value thereof; and the decision upon all claims, questions, and disputes shall be final and binding upon the parties hereto. Adjustments of compensation and contract time because of any major changes in the work that may become necessary or desirable as the work progresses shall be subject to mutual agreement of the parties, and amendment(s) shall be entered into by the parties in accordance herewith.

Reference herein to the Director shall mean the

Executive Director and Chief Executive Officer, Florida’s Turnpike Enterprise

## 2. TERM

- A. Initial Term. This Agreement shall begin on date of execution and shall remain in full force and effect through completion of all services required or as selected below, whichever occurs first. Subsequent to the execution of this Agreement by both parties, the services to be rendered by the Vendor shall commence and be completed in accordance with the option selected below. (Select box and indicate date(s) as appropriate):
- Services shall commence \_\_\_\_\_ and shall be completed by \_\_\_\_\_ or date of termination, whichever occurs first.
  - Services shall commence upon written notice from the Department’s Project/Contract Manager and shall be completed within sixty (60) calendar days thereafter or date of termination, whichever occurs first.
  - Other: See Exhibit “A”
- B. RENEWALS (Select appropriate box):
- This Agreement may not be renewed.
  - This Agreement may be renewed for a period that may not exceed three (3) years or the term of the original contract, whichever is longer. Renewals are contingent upon satisfactory performance evaluations by the Department and subject to the availability of funds. Costs for renewal may not be charged. Any renewal or extension must be in writing and is subject to the same terms and conditions set forth in this Agreement and any written amendments signed by the parties.
- C. EXTENSIONS. In the event that circumstances arise which make performance by the Vendor impracticable or impossible within the time allowed or which prevent a new contract from being executed, the Department, in its discretion, may grant an extension of this Agreement. Extension of this Agreement must be in writing for a period not to exceed six (6) months and is subject to the same terms and conditions set forth in this Agreement and any written amendments signed by the parties; provided the Department may, in its discretion, grant a proportional increase in the total dollar amount based on the method and rate established herein. There may be only one extension of this Agreement unless the failure to meet the criteria set forth in this Agreement for completion of this Agreement is due to events beyond the control of the Vendor.

It shall be the responsibility of the Vendor to ensure at all times that sufficient time remains in the Project Schedule within which to complete services on the project. In the event there have been delays which would affect the project completion date, the Vendor shall submit a written request to the Department which identifies the reason(s) for the delay and the amount of time related to each reason. The Department shall review the request and make a determination as to granting all or part of the requested extension.

## 3. COMPENSATION AND PAYMENT

- A. Payment shall be made only after receipt and approval of goods and services unless advance payments are authorized by the Chief Financial Officer of the State of Florida under Chapters 215 and 216, Florida Statutes. Deliverable(s) must be received and accepted in writing by the Contract Manager on the Department’s invoice transmittal forms prior to payment. If the Department determines that the performance of the Vendor is unsatisfactory, the Department shall notify the Vendor of the deficiency to be corrected, which correction shall be made within a time-frame to be specified by the Department. The Vendor shall, within five days after notice from the Department, provide the Department with a corrective action plan describing how the Vendor will address all issues of contract non-performance, unacceptable performance, failure to meet the minimum performance levels, deliverable deficiencies, or contract noncompliance. If the corrective action plan is unacceptable to the Department, the Vendor shall be assessed a non-performance retainage equivalent to 10% of the total invoice amount. The retainage shall be applied to the invoice for the then-current billing period. The retainage shall be withheld until the vendor resolves the deficiency. If the deficiency is subsequently resolved, the Vendor may bill the Department for the retained amount during the next billing period. If the Vendor is unable to resolve the deficiency, the funds retained may be forfeited at the end of the agreement period.
- B. If this Agreement involves units of deliverables, then such units must be received and accepted in writing by the Contract Manager prior to payments.
- C. Bills for fees or other compensation for services or expenses shall be submitted in detail sufficient for a proper preaudit and postaudit thereof.
- D. The bills for any travel expenses, when authorized by terms of this Agreement and by the Department’s Project Manager, shall be submitted in accordance with Section 112.061, Florida Statutes. In addition, if compensation for travel is authorized under this Agreement and by the Department’s Project Manager, then the Department shall not compensate the Vendor for lodging/hotel expenses in excess of \$150.00 per day (excluding taxes and fees). The Vendor may expend their own funds to the extent the lodging/hotel expense exceeds \$150.00 per day. The Department, in its sole discretion and pursuant to its internal policies and procedures, may approve compensation to the Vendor for lodging/hotel expenses in excess of \$150.00 per day.
- E. Vendors providing goods and services to the Department should be aware of the following time frames. Upon receipt, the Department has five (5) working days to inspect and approve the goods and services, unless otherwise specified herein. The Department has twenty (20) days to deliver a request for payment (voucher) to the Department of Financial Services. The twenty (20) days are measured from the latter of the date the invoice is received or the goods or services are received, inspected and approved.

- F. If a payment is not available within forty (40) days, a separate interest penalty as established pursuant to Section 215.422, Florida Statutes, shall be due and payable, in addition to the invoice amount, to the Vendor. Interest penalties of less than one (1) dollar shall not be enforced unless the Vendor requests payment. Invoices which have to be returned to a Vendor because of Vendor preparation errors shall result in a delay in the payment. The invoice payment requirements do not start until a properly completed invoice is provided to the Department.
- G. The State of Florida, through the Department of Management Services, has instituted MyFloridaMarketPlace, a statewide eProcurement system. Pursuant to Section 287.057(22), Florida Statutes, all payments shall be assessed a transaction fee of one percent (1%), which the Vendor shall pay to the State. For payments within the State accounting system (FLAIR or its successor), the transaction fee shall, when possible, be automatically deducted from payments to the Vendor. If automatic deduction is not possible, the Vendor shall pay the transaction fee pursuant to Rule 60A-1.031(2), Florida Administrative Code. By submission of these reports and corresponding payments, Vendor certifies their correctness. All such reports and payments shall be subject to audit by the State or its designee. The Vendor shall receive a credit for any transaction fee paid by the Vendor for the purchase of any item(s) if such item(s) are returned to the Vendor through no fault, act, or omission of the Vendor. Notwithstanding the foregoing, a transaction fee is non-refundable when an item is rejected or returned, or declined, due to the Vendor's failure to perform or comply with specifications or requirements of the Agreement. Failure to comply with these requirements shall constitute grounds for declaring the Vendor in default and recovering procurement costs from the Vendor in addition to all outstanding fees. VENDORS DELINQUENT IN PAYING TRANSACTION FEES MAY BE EXCLUDED FROM CONDUCTING FUTURE BUSINESS WITH THE STATE.
- H. A vendor ombudsman has been established within the Department of Financial Services. The duties of this individual include acting as an advocate for vendors who may be experiencing problems in obtaining timely payment(s) from a state agency. The Vendor Ombudsman may be contacted at (850) 413-5516.
- I. Records of costs incurred under terms of this Agreement shall be maintained and made available upon request to the Department at all times during the period of this Agreement and for three (3) years after final payment for the work pursuant to this Agreement is made. Copies of these documents and records shall be furnished to the Department upon request. Records of costs incurred shall include the Vendor's general accounting records and the project records, together with supporting documents and records of the Vendor and all subcontractors performing work on the project, and all other records of the Vendor and subcontractors considered necessary by the Department for a proper audit of project costs.
- J. The Department, during any fiscal year, shall not expend money, incur any liability, or enter into any contract which, by its terms, involves the expenditure of money in excess of the amounts budgeted as available for expenditure during such fiscal year. Any contract, verbal or written, made in violation of this subsection is null and void, and no money may be paid on such contract. The Department shall require a statement from the comptroller of the Department that funds are available prior to entering into any such contract or other binding commitment of funds. Nothing herein contained shall prevent the making of contracts for periods exceeding one (1) year, but any contract so made shall be executory only for the value of the services to be rendered or agreed to be paid for in succeeding fiscal years. Accordingly, the Department's performance and obligation to pay under this Agreement is contingent upon an annual appropriation by the Legislature.

#### 4. INDEMNITY AND PAYMENT FOR CLAIMS

- A. INDEMNITY: To the extent permitted by Florida Law, the Vendor shall indemnify and hold harmless the Department, its officers and employees from liabilities, damages, losses, and costs, including, but not limited to, reasonable attorney's fees, to the extent caused by negligence, recklessness, or intentional wrongful misconduct of the Vendor and person employed or utilized by the Vendor in the performance of this Agreement.

It is specifically agreed between the parties executing this Agreement that it is not intended by any of the provisions of any part of the Agreement to create in the public or any member thereof, a third party beneficiary hereunder, or to authorize anyone not a party to this Agreement to maintain a suit for personal injuries or property damage pursuant to the terms or provision of this Agreement.

PAYMENT FOR CLAIMS: The Vendor guaranties the payment of all just claims for materials, supplies, tools, or labor and other just claims against the Vendor or any subcontractor, in connection with the Agreement. The Department's final acceptance and payment does not release the Vendor's bond until all such claims are paid or released.

- B. LIABILITY INSURANCE. (Select and complete as appropriate):
- No general liability insurance is required.
  - The Vendor shall carry and keep in force during the term of this Agreement, a general liability insurance policy or policies with a company or companies authorized to do business in Florida, affording public liability insurance with a combined bodily injury limits of at least \$200,000.00 per person and \$300,000.00 each occurrence, and property damage insurance of at least \$200,000.00 each occurrence, for the services to be rendered in accordance with this Agreement.
  - The Vendor shall have and maintain during the term of this Agreement, a professional liability insurance policy or policies or an irrevocable letter of credit established pursuant to Chapter 675 Section 337.106, Florida Statutes, with a company or companies authorized to do business in the State of Florida, affording liability coverage for the professional services to be rendered in with this Agreement in the amount of \$ \_\_\_\_\_.
- C. WORKERS' COMPENSATION. The Vendor shall also carry and keep in force Workers' Compensation insurance as required for the State of Florida under the Workers' Compensation Law.

D. PERFORMANCE AND PAYMENT BOND. (Select as appropriate):

- o No Bond is required.
- Prior to commencement of any services pursuant to this Agreement and at all times during the term hereof, including renewals and extensions, the Vendor will supply to the Department and keep in force a bond provided by a surety authorized to do business in the State of Florida, payable to the Department and conditioned for the prompt, faithful, and efficient performance of this Agreement according to the terms and conditions hereof and within the time periods specified herein, and for the prompt payment of all persons furnishing labor, materials, equipment, and supplies therefore.

E. CERTIFICATION. With respect to any general liability insurance policy required pursuant to this Agreement, all such policies shall be issued by companies licensed to do business in the State of Florida. The Vendor shall provide to the Department certificates showing the required coverage to be in effect with endorsements showing the Department to be an additional insured prior to commencing any work under this Contract. Policies that include Self Insured Retention (SIR) will not be accepted. The certificates and policies shall provide that in the event of any material change in or cancellation of the policies reflecting the required coverage, thirty days advance notice shall be given to the Department or as provided in accordance with Florida law.

5. COMPLIANCE WITH LAWS

A. The Vendor shall comply with Chapter 119, Florida Statutes. Specifically, the Vendor shall:

- (1) Keep and maintain public records required by the Department to perform the service.
- (2) Upon request from the Department's custodian of public records, provide the Department with a copy of the requested records or allow the records to be inspected or copied within a reasonable time at a cost that does not exceed the cost provided in Chapter 119, Florida Statutes, or as otherwise provided by law.
- (3) Ensure that public records that are exempt or confidential and exempt from public records disclosure requirements are not disclosed except as authorized by law for the duration of the Agreement term and following completion of the Agreement if the Vendor does not transfer the records to the Department.
- (4) Upon completion of the Agreement, transfer, at no cost, to the Department, all public records in possession of the Vendor or keep and maintain public records required by the Department to perform the service. If the Vendor transfers all public records to the Department upon completion of the Agreement, the Vendor shall destroy any duplicate public records that are exempt or confidential and exempt from public records disclosure requirements. If the Vendor keeps and maintains public records upon completion of the Agreement, the Vendor shall meet all applicable requirements for retaining public records. All records stored electronically must be provided to the Department, upon request from the Department's custodian of public records, in a format that is compatible with the information technology systems of the Department.

Failure by the Vendor to comply with Chapter 119, Florida Statutes, shall be grounds for immediate unilateral cancellation of this Agreement by the Department.

**IF THE VENDOR HAS QUESTIONS REGARDING THE APPLICATION OF CHAPTER 119, FLORIDA STATUTES, TO THE VENDOR'S DUTY TO PROVIDE PUBLIC RECORDS RELATING TO THIS AGREEMENT, CONTACT THE CUSTODIAN OF PUBLIC RECORDS AT:**

Turnpike Enterprise Chief Counsel, Florida Turnpike - Office of General Counsel, Turnpike Mile Post 263, Bldg. 5315, Ocoee, FL 34761, (407) 264-3170, TPprcustodian@dot.state.fl.us

- B. The Vendor agrees that it shall make no statements, press releases or publicity releases concerning this Agreement or its subject matter or otherwise discuss or permit to be disclosed or discussed any of the data or other information obtained or furnished in compliance with this Agreement, or any particulars thereof, during the period of the Agreement, without first notifying the Department's Contract Manager and securing prior written consent. The Vendor also agrees that it shall not publish, copyright, or patent any of the data developed under this Agreement, it being understood that such data or information are works made for hire and the property of the Department.
- C. The Vendor shall comply with all federal, state, and local laws and ordinances applicable to the work or payment for work thereof, and will not discriminate on the grounds of race, color, religion, sex, national origin, age, or disability in the performance of work under this Agreement.
- D. If the Vendor is licensed by the Department of Business and Professional Regulation to perform the services herein contracted, then Section 337.162, Florida Statutes, applies as follows:
  - (1) If the Department has knowledge or reason to believe that any person has violated the provisions of the state professional licensing laws or rules, it shall submit a complaint regarding the violations to the Department of Business and Professional Regulation. The complaint shall be confidential.



- (2) Any person who is employed by the Department and who is licensed by the Department of Business and Professional Regulation and who, through the course of the person's employment, has knowledge to believe that any person has violated the provisions of state professional licensing laws or rules shall submit a complaint regarding the violations to the Department of Business and Professional Regulation. Failure to submit a complaint about the violations may be grounds for disciplinary action pursuant to Chapter 455, Florida Statutes, and the state licensing law applicable to that licensee. The complaint shall be confidential.
- (3) Any complaints submitted to the Department of Business and Professional Regulation are confidential and exempt from Section 119.07(1), Florida Statutes, pursuant to Chapter 455, Florida Statutes, and applicable state law.

- E. The Vendor covenants and agrees that it and its employees and agents shall be bound by the standards of conduct provided in applicable law and applicable rules of the Board of Business and Professional Regulation as they relate to work performed under this Agreement. The Vendor further covenants and agrees that when a former state employee is employed by the Vendor, the Vendor shall require that strict adherence by the former state employee to Sections 112.313 and 112.3185, Florida Statutes, is a condition of employment for said former state employee. These statutes will by reference be made a part of this Agreement as though set forth in full. The Vendor agrees to incorporate the provisions of this paragraph in any subcontract into which it might enter with reference to the work performed pursuant to this Agreement.
- F. A person or affiliate who has been placed on the convicted vendor list following a conviction for a public entity crime may not submit a bid, proposal, or reply on a contract to provide any goods or services to a public entity, may not submit a bid, proposal, or reply on a contract with a public entity for the construction or repair of a public building or public work, may not submit a bids, proposals, or replies on leases of real property to a public entity, may not be awarded or perform work as a contractor, supplier, subcontractor, or consultant under a contract with any public entity, and may not transact business with any public entity in excess of the threshold amount provided in Section 287.017, Florida Statutes, for CATEGORY TWO for a period of thirty-six (36) months following the date of being placed on the convicted vendor list.
- G. An entity or affiliate who has been placed on the discriminatory vendor list may not submit a bid, proposal, or reply on a contract to provide any goods or services to a public entity, may not submit a bid, proposal, or reply on a contract with a public entity for the construction or repair of a public building or public work, may not submit bids, proposals, or replies on leases of real property to a public entity, may not be awarded or perform work as a contractor, supplier, subcontractor, or consultant under a contract with a public entity, and may not transact business with any public entity.
- H. The Department shall consider the employment by any vendor of unauthorized aliens a violation of Section 274A(e) of the Immigration and Nationality Act. If the Vendor knowingly employs unauthorized aliens, such violation shall be cause for unilateral cancellation of this agreement.
- I. The Vendor agrees to comply with the Title VI Nondiscrimination Contract Provisions Appendices A and E, available at <http://www.dot.state.fl.us/procurement/index.shmt>, incorporated herein by reference and made a part of this Agreement.
- J. Pursuant to Section 216.347, Florida Statutes, the vendor may not expend any State funds for the purpose of lobbying the Legislature, the judicial branch, or a state agency.
- K. Any intellectual property developed as a result of this Agreement will belong to and be the sole property of the State. This provision will survive the termination or expiration of the Agreement.
- L. The Vendor agrees to comply with s.20.055(5), Florida Statutes, and to incorporate in all subcontracts the obligation to comply with s.20.055(5), Florida Statutes.

## 6. TERMINATION AND DEFAULT

- A. This Agreement may be canceled by the Department in whole or in part at any time the interest of the Department requires such termination. The Department reserves the right to terminate or cancel this Agreement in the event an assignment be made for the benefit of creditors.
- B. If the Department determines that the performance of the Vendor is not satisfactory, the Department shall have the option of (a) immediately terminating the Agreement, or (b) notifying the Vendor of the deficiency with a requirement that the deficiency be corrected within a specified time, otherwise the Agreement will be terminated at the end of such time, or (c) taking whatever action is deemed appropriate by the Department.
- C. If the Department requires termination of the Agreement for reasons other than unsatisfactory performance of the Vendor, the Department shall notify the Vendor of such termination, with instructions as to the effective date of termination or specify the stage of work at which the Agreement is to be terminated.
- D. If the Agreement is terminated before performance is completed, the Vendor shall be paid only for that work satisfactorily performed for which costs can be substantiated. Such payment, however, may not exceed an amount which is the same percentage of the agreement price as the amount of work satisfactorily completed is a percentage of the total work called for by this Agreement. All work in progress shall become the property of the Department and shall be turned over promptly by the Vendor.

- E. A Vendor is ineligible to enter into a contract with the Department for goods or services of any amount if, at the time of entering into such contract, the Vendor is on the Scrutinized Companies that Boycott Israel List, created pursuant to Section 215.4725, Florida Statutes, or is engaged in a boycott of Israel, Section 287.135, Florida Statutes, also prohibits companies from entering into a contract for goods or services of \$1 million or more that are on either the Scrutinized Companies with Activities in Sudan List or the Scrutinized Companies with Activities in the Iran Petroleum Energy Sector Lists which were created pursuant to s. 215.473, Florida Statutes. If the Department determines the Vendor submitted a false certification under Section 287.135 of the Florida Statutes, the Department shall either terminate the Contract after it has given the Vendor notice and an opportunity to demonstrate the Department's determination of false certification was in error pursuant to Section 287.135 of the Florida Statutes, or maintain the Contract if the conditions of Section 287.135 of the Florida Statutes are met.

## 7. ASSIGNMENT AND SUBCONTRACTS

- A. The Vendor shall maintain an adequate and competent staff so as to enable the Vendor to timely perform under this Agreement and may associate with it such subcontractors, for the purpose of its services hereunder, without additional cost to the Department, other than those cost within the limits and terms of this Agreement. The Vendor is fully responsible for satisfactory completion of all subcontracted work. The Vendor, however, shall not sublet, assign, or transfer any work under this Agreement to other than subcontractors specified in the proposal, bid, and/or Agreement without the written consent of the Department.

- B. Select the Appropriate box:

- The following provision is not applicable to this Agreement:
- The following provision is hereby incorporated in and made a part of this Agreement:

It is expressly understood and agreed that any articles that are the subject of, or required to carry out this Agreement shall be purchased from a nonprofit agency for the blind or for the severely handicapped that is qualified pursuant to Chapter 413, Florida Statutes, in the same manner and under the same procedures set forth in Section 413.036(1) and (2), Florida Statutes; and for purposes of this Agreement the person, firm, or other business entity (Vendor) carrying out the provisions of this Agreement shall be deemed to be substituted for the state agency (Department) insofar as dealings with such qualified nonprofit agency are concerned. RESPECT of Florida provides governmental agencies within the State of Florida with quality products and services produced by persons with disabilities. Available pricing, products, and delivery schedules may be obtained by contacting:

RESPECT  
2475 Apalachee Pkwy  
Tallahassee, Florida 32301-4946  
Phone: (850) 487-1471

- The following provision is hereby incorporated in and made a part of this Agreement:

It is expressly understood and agreed that any articles which are the subject of, or required to carry out this Agreement shall be purchased from the corporation identified under Chapter 946, Florida Statutes, in the same manner and under the procedures set forth in Section 946.515(2) and (4), Florida Statutes; and for purposes of this Agreement the person, firm, or other business entity (Vendor) carrying out the provisions of this Agreement shall be deemed to be substituted for this agency (Department) insofar as dealings with such corporation are concerned. The "corporation identified" is Prison Rehabilitative Industries and Diversified Enterprises, Inc. (PRIDE). Available pricing, products, and delivery schedules may be obtained by contacting:

PRIDE Enterprises  
12425 – 28<sup>th</sup> Street, North  
St. Petersburg, FL 33716-1826  
(800) 643-8459

- This Agreement involves the expenditure of federal funds and Section 946.515, Florida Statutes, as noted above, does not apply. However, Appendix I is applicable to all parties and is hereof made a part of this Agreement.

## 8. MISCELLANEOUS

- A. The Vendor and its employees, agents, representatives, or subcontractors are not employees of the Department and are not entitled to the benefits of State of Florida employees. Except to the extent expressly authorized herein, Vendor and its employees, agents, representative, or subcontractors are not agents of the Department or the State for any purpose or authority such as to bind or represent the interests thereof, and shall not represent that it is an agent or that it is acting on the behalf of the Department or the State. The Department shall not be bound by any unauthorized acts or conduct of the Vendor or its employees, agents, representatives, or subcontractors. Vendor agrees to include this provision in all its subcontract under this Agreement.
- B. All words used herein in the singular form shall extend to and include the plural. All words used in the plural form shall extend to and include the singular. All words used in any gender shall extend to and include all genders.
- C. This Agreement embodies the whole agreement of the parties. There are no promises, terms, conditions, or obligations other than those contained herein, and this Agreement shall supersede all previous communications, representations, or agreements, either verbal or written, between the parties hereto. The State of Florida terms and conditions, whether general or specific, shall take precedence over and supersede any inconsistent or conflicting provision in any attached terms and conditions of the Vendor.

- D. It is understood and agreed by the parties hereto that if any part, term or provision of this Agreement is by the courts held to be illegal or in conflict with any law of the State of Florida, the validity of the remaining portions or provisions shall not be affected, and the rights and obligations of the parties shall be construed and enforced as if the Agreement did not contain the particular part, term, or provision held to be invalid.
- E. This Agreement shall be governed by and construed in accordance with the laws of the State of Florida.
- F. In any legal action related to this Agreement, instituted by either party, the Vendor hereby waives any and all privileges and rights it may have under Chapter 47 and Section 337.19, Florida Statutes, relating to venue, as it now exists or may hereafter be amended, and any and all such privileges and rights it may have under any other statute, rule, or case law, including, but not limited to those grounded on convenience. Any such legal actions may be brought in the appropriate Court in the county chosen by the Department and in the event that any such legal action is filed by the Vendor, the Vendor hereby consents to the transfer of venue to the county chosen by the Department upon the Department filing a motion requesting the same.
- G. If this Agreement involves the purchase or maintenance of information technology as defined in Section 282.0041, Florida Statutes, the selected provisions of the attached Appendix II are made a part of this Agreement.
- H. If this Agreement is the result of a formal solicitation (Invitation to Bid, Request for Proposal or Invitation to Negotiate), the Department of Management Services Form PUR1000 and PUR1001, included in the solicitation, are incorporated herein by reference and made a part of this Agreement.
- I. The Department may grant the Vendor's employees or subconsultants access to the Department's secure networks as part of the project. In the event such employees' or subconsultants' participation in the project is terminated or will be terminated, the Vendor shall notify the Department's project manager no later than the employees' or subconsultants' separation date from participation in the project or immediately upon the Vendor acquiring knowledge of such termination of employees' or subconsultants' participation in the project, whichever occurs later.
- J. Vendors/Contractor:
  - 1. shall utilize the U.S. Department of Homeland Security's E-Verify system to verify the employment eligibility of all new employees hired by the Vendor/Contractor during the term of the Contract; and
  - 2. shall expressly require any subcontractors performing work or providing services pursuant to the state contract to likewise utilize the U.S. Department of Homeland Security's E-Verify system to verify the employment eligibility of all new employees hired by the subcontractor during the Contract term.
- K. Time is of the essence as to each and every obligation under this Agreement.
- L. The following attachments are incorporated and made a part of this agreement:  
Exhibit "A," Scope of Services, Attachments, "A-C," Exhibit "B," Method of Compensation, and Exhibit "C," Bid Blank
- M. Other Provisions:

IN WITNESS WHEREOF, the parties have executed this Agreement by their duly authorized officer on the day, month and year set forth above.

_____	STATE OF FLORIDA
Name of Vendor	DEPARTMENT OF TRANSPORTATION
BY: _____	BY: _____
Authorized Signature	Authorized Signature
_____	<u>Nicola Liquori</u>
(Print/Type)	(Print/Type)
Title: _____	Title: <u>Executive Director and Chief Executive Officer</u>

---

FOR DEPARTMENT USE ONLY

APPROVED:

LEGAL REVIEW:

**FLORIDA DEPARTMENT  
OF TRANSPORTATION**



**EXHIBITS & ATTACHMENTS**  
**TABLE OF CONTENTS**

**DOT-ITB-20-8025-AC**

**GENERATOR, FUEL TANK AND AUTOMATIC TRANSFER SWITCH (ATS) REPLACEMENT  
AT MID-BAY BRIDGE ADMINISTRATION BUILDING, SR 293, MILEPOST 5.0**

**FPID: 413878-1-93-11**

## TABLE OF CONTENTS

**EXHIBIT “A”**

**SCOPE OF SERVICES (PAGES A-1 THRU A-8)**

<b>Section 1</b>	<b>Introduction.....</b>	<b>A – 1</b>
1.1	Description of Services .....	A – 1
1.2	Definition of Terms .....	A – 1
<b>Section 2</b>	<b>Locations and Site Descriptions .....</b>	<b>A – 2</b>
<b>Section 3</b>	<b>Vendor’s Qualifications .....</b>	<b>A – 2</b>
3.1	Certification and Registration .....	A – 2
3.2	Business Location .....	A – 2
3.3	Certification of Experience .....	A – 2
3.4	Performance Bond.....	A – 2
<b>Section 4</b>	<b>Scope of Services.....</b>	<b>A – 2</b>
4.1	Replacement Requirements for Generator, Fuel Tank and ATS.....	A – 2
4.2	General Notes and Other Requirements .....	A – 3
4.3	Parts or Materials Requirements .....	A – 4
4.4	Tools and/or Equipment .....	A – 4
4.5	Submittals.....	A – 4
4.6	Work Schedule .....	A – 4
4.7	Sign-in and Sign-out.....	A – 4
4.8	Work Status .....	A – 4
4.9	Lighting, Water and Power Source at the Site .....	A – 4
4.10	Notification of Damages and Damage Repair.....	A – 5
4.11	Clean-up and Disposal.....	A – 5
4.12	Uniforms.....	A – 5
4.13	Performance Measures .....	A – 5
4.14	Subletting or Assigning of Work.....	A – 6
4.15	Notice of Claim .....	A – 6
<b>Section 5</b>	<b>Safety and Worker Protection.....</b>	<b>A – 6</b>
5.1	Safety and Worker Protection Requirements .....	A – 6
5.2	Delay of Work Due to Weather or Other Causes .....	A – 7
5.3	Lock-out/Tag-out .....	A – 7
5.4	U-Turns .....	A – 7
<b>Section 6</b>	<b>The Department’s Responsibilities .....</b>	<b>A – 7</b>
6.1	Administration of Contract.....	A – 7
6.2	Pre-work Conference.....	A – 7
6.3	Periodic Inspection .....	A – 7
6.4	Performance Evaluation .....	A – 8
<b>Section 7</b>	<b>Duration of Contract.....</b>	<b>A – 8</b>

**ATTACHMENTS**

**(ATTACHMENTS “A” THRU “C”)**

A.	Design Criteria .....	AT – A
B.	Certification Disbursement of Previous Payments.....	AT – B
C.	Certificate of Contract Completion .....	AT – C

**EXHIBIT “B”**

**METHOD OF COMPENSATION**

**(PAGES B-1 THRU B-2)**

<b>Section 1</b>	<b>General .....</b>	<b>B – 1</b>
<b>Section 2</b>	<b>Pay Item Definition (Basis of Payment) .....</b>	<b>B – 1</b>
2.1	Generator, Fuel Tank and ATS Replacement Services .....	B – 1
<b>Section 3</b>	<b>Method of Measurement.....</b>	<b>B – 1</b>
3.1	Compensation.....	B – 1
3.2	Invoicing.....	B – 1
3.3	Certification Disbursement of Previous Payments Requirement .....	B – 2
3.4	Certification of Contract Completion Requirement .....	B – 2
3.5	Disallowed Payments .....	B – 2

**EXHIBIT “C”**

**BID BLANK**

**(PAGES C-1 THRU C-2)**

	Bid Blank Sheet.....	C – 1
	Document Submittal Checklist.....	C – 2
	Vendor’s Information.....	C – 2

**FLORIDA DEPARTMENT  
OF TRANSPORTATION**



**EXHIBIT "A"**  
**SCOPE OF SERVICES**

**DOT-ITB-20-8025-AC**

**GENERATOR, FUEL TANK AND AUTOMATIC TRANSFER SWITCH (ATS) REPLACEMENT  
AT MID-BAY BRIDGE ADMINISTRATION BUILDING, SR 293, MILEPOST 5.0**

**FPID: 413878-1-93-11**

## **EXHIBIT "A"**

### **SCOPE OF SERVICES**

#### **GENERATOR, FUEL TANK AND AUTOMATIC TRANSFER SWITCH (ATS) REPLACEMENT AT MID-BAY BRIDGE ADMINISTRATION BUILDING, SR 293, MILEPOST 5.0**

### **1.0 Introduction**

#### **1.1 Description of Services**

The work specified under this Contract shall consist of providing all labor, materials, equipment, and incidentals necessary to perform the replacement of existing emergency standby generator, fuel tank and automatic transfer switch (ATS) including providing temporary portable emergency standby generator at Mid-Bay Bridge Administration Building.

#### **1.2 Definition of Terms**

For the purpose of this Contract, whenever the following terms appear, their intent and meaning shall, unless specifically stated otherwise, be interpreted as shown hereunder:

**Contract:** The term "Contract" means the entire and integrated Agreement between the Department and the Vendor (hereinafter collectively referred to as the "Parties"), which supersedes all prior negotiations, representations, or agreements, either written or oral. The Contract documents (Standard Written Agreement, Exhibit "A," Scope of Services, Exhibit "B," Method of Compensation, Exhibit "C," Bid Blank, Attachments, and any amendments and supplements thereto) form the Contract between, and otherwise set forth the obligations of the Parties, including the performance of the work and the basis of payment.

**Department:** State of Florida Department of Transportation, Florida Turnpike Enterprise.

**Vendor:** The firm selected through the competitive bid process to provide the services requested herein.

**Department's Project/Contract Manager:** The individual employee(s) of the Department responsible for the management of the Contract, scheduling and monitoring of work being performed, inspection and acceptance of services provided and approval for payment of services requested herein.

**Vendor's Project Manager:** The individual employee of the Vendor responsible for the management of the Contract, scheduling and monitoring of work being performed, inspection of services provided and the submission of payment documents for all services requested herein. The Vendor's Project Manager is responsible for all communication with the Department and the Department's Project/Contract Manager.

**Supplemental Agreement:** A written agreement between the Vendor and the Department modifying the Contract within the limitations set forth in the Contract, and as provided by law.

**Work Document/Authorization:** A work request issued periodically to the Vendor for work required at the Contract locations, describing work and pay item quantities authorized to the Vendor to proceed with the work.

**Turnpike Facilities:** Turnpike facilities may include administrative offices, communications buildings, law enforcement offices, maintenance facilities, storage buildings, pump houses, services plazas, office buildings, hub buildings, and toll plazas which included toll buildings, tollbooths, canopies, tech shop buildings, generator buildings, concrete walls, barriers, curbs, walkways and other related buildings and structures within the Department's Right of Way.



## 2.0 Locations and Site Descriptions

This site is located at 1200 White Point Road, Niceville, Florida 32578.

## 3.0 Vendor's Qualifications

The Vendor shall maintain and keep in force throughout the life of the Contract, renewals, and extensions, the requirements specified below. Failure of the Vendor to comply with these requirements will be sufficient grounds for the Department to declare the Vendor in accordance with the terms of Section 6; Termination and Default, of the Standard Written Agreement.

### 3.1 Certification and Registration

- A. The Vendor providing services shall hold and keep in force during the term of the Contract, a valid and current certificate/license, in accordance with the laws of the State of Florida, authorizing the Vendor, or approved sub-vendor, to perform the specified work and have all required federal, state, and local licenses and permits. A copy of all required licenses and/or certifications for this Contract shall be submitted and included with the Vendor's bid package.
- B. All sub-vendors shall be properly licensed meeting the requirements under the respective trade category for the work to be performed under this Contract.

### 3.2 Business Location

The Vendor shall have a current and valid Business Tax Receipt which states the name of the Vendor, street address of the business where all the work covered under the Contract will be handled, and the type of work that the Business Tax Receipt is issued for (which must be for the same type of services required in the Contract). If awarded the Contract, the Vendor shall be required to provide the Department verification of a Business Tax Receipt in the county the services are being provided (Okaloosa) at the Pre-work Conference.

### 3.3 Certification of Experience

The organized business enterprise (e.g. corporation, LLC or sole proprietorship) shall have been licensed and actively involved in the type of business requested in the scope of work for this Contract for a minimum of three (3) years. The Vendor shall submit documentation of the work experience with its bid package.

### 3.4 Performance Bond

Prior to commencement of any services pursuant to this Contract and at all times during the term hereof, including renewals and extensions, the Vendor will supply to the Department and keep in force a bond provided by a surety company authorized to do business in the State of Florida, payable to the Department and conditioned for the prompt, faithful, and efficient performance of this Contract according to the terms and conditions hereof and within the time periods specified herein, and for the prompt payment of all persons furnishing labor, materials, equipment, and supplies therefore.

**The bidder must submit, with its bid**, a current letter from a surety company or bonding agent authorized to do business in the State of Florida and written on company letterhead, to document the bidder's present ability to obtain a Performance Bond in the full amount of the bid. Failure by the bidder to provide this letter with its bid will constitute a non-responsive determination for its bid.

## 4.0 Scope of Services

### 4.1 Replacement Requirements for Generator, Fuel Tank and ATS:

The work specified under this Contract shall consist of providing all labor, materials, equipment and incidentals necessary to perform replacement of existing emergency standby generators, fuel tank and automatic transfer switch (ATS) as specified below.

- A. Detailed scope of work is found in Attachment "A," Design Criteria.
- B. Department Provided Generator, ATS and Fuel Tank:
  - 1. The Vendor shall provide all labor, materials, equipment, transportation, and other related incidentals necessary for the installation of Department provided 80KW Cummins generator, automatic transfer switch (ATS) and 500-gal. ConVault fuel tank including aluminum fencing at Mid-Bay Bridge Mainline Plaza, Niceville, Florida.
  - 2. The Vendor shall completely de-energize and disconnect all fuel lines and electrical wiring of the existing generator system.
  - 3. If any scratches develop from the installation of the emergency generators, the generator shall be repainted or epoxy primed and coated before acceptance of the equipment.
  - 4. The Vendor shall furnish and install a battery charger and block heater specific to the unit and shall also be checked by the Vendor for proper operation.
- C. Portable Emergency Standby Generator:
  - 1. The Vendor shall supply a portable emergency standby generator at the location for use beginning when the existing generator system is disconnected until the installation of the Department provided generator is complete. A maximum of one (1) hour is allowed when making the final connections for the new generator and disconnecting the portable emergency standby generator. The Vendor shall make all efforts to minimize the time that the facility is without backup emergency power. Under no circumstances shall a site be without a working generator and ATS. Power outages shall be scheduled with the Department's Project/Contract Manager and the site Supervisor. Power outages shall not be performed during peak hours of traffic.
  - 2. The Vendor supplied portable standby emergency generator shall be connected, tested and fully operational. The Vendor shall ensure that portable emergency standby generators are properly maintained and fueled while in use and that the facility has continuous backup emergency power. It shall be the Vendor's responsibility to disconnect all portable emergency standby generators prior to making the final connection to the new generators.

#### 4.2 General Notes and Other Requirements

- A. The Vendor shall examine the Contract documents and each site of the proposed work carefully before submitting a proposal for the work contemplated under this Contract. The Vendor shall investigate the conditions to be encountered, as to the character, quality, and quantities of work to be performed and materials to be furnished and as to the requirements of all Contract documents.
- B. Prior to beginning work under this Contract, the Vendor shall submit to the Department for approval, a copy of the Vendor's proposed plan and methods for performing the work, including a listing of equipment and personnel anticipated for use.
- C. The Vendor shall maintain adequate and competent personnel so as to enable the Vendor to complete the assigned work within the time period indicated in Section 7.0, Duration of Contract, of this Exhibit.
- D. The Vendor shall execute the work in an orderly and efficient manner. The Vendor shall proceed with the work with all due diligence and use all reasonable efforts to complete the same without delay; failure to do so may constitute unsatisfactory performance, and after written warning, the Vendor may be declared in default.
- E. The Vendor and sub-vendor shall ensure that all motor vehicles used on this project are registered and insured. All drivers shall be licensed in the State of Florida.

F. The Department shall have the right to suspend the work wholly or in part, for such period or periods as the Department deems necessary. The Department will order such suspension in writing, detailing the reasons for the suspension and the Vendor shall not resume operations until it receives written authorization from the Department to do so.

#### 4.3 Parts or Materials Requirements

- A. Parts or materials provided by the Vendor for this project shall be new.
- B. The Vendor shall ensure that all parts, materials, equipment and incidentals incorporated into the work are completely free of any type of asbestos materials.

#### 4.4 Tools and/or Equipment

The Vendor shall be responsible for providing all tools and/or equipment (owned, leased or rented) that may be needed for this project.

#### 4.5 Submittals

At the Pre-work Conference, the Vendor shall submit a copy of the following documents to the Department's Project/Contract Manager for the Department's review and records:

- A. A list of all personnel anticipated for employment under this Contract.
- B. List of Vehicles.
- C. Vendor's Traffic Control Plan (if applicable).
- D. Emergency Phone List.
- E. Documents provided by the Department with the pre-work package. The Vendor shall complete and return all required documents prior to the issuance of the Notice to Proceed (NTP).
- F. Project Schedule
- G. Schedule of Values
- H. Business Tax Receipt in the county the services are being provided (Okaloosa)

#### 4.6 Work Schedule

The Vendor shall perform all work, unless otherwise approved by the Department's Project/Contract Manager, strictly between the hours of 7:00 a.m. and 5:00 p.m. local time, Monday through Friday, excluding state holidays.

#### 4.7 Sign-in and Sign-out

Upon arrival to the site, the Vendor, sub-vendors and their employees shall immediately notify the Department's Project/Contract Manager and immediately report to the Department's Toll Plaza Supervisor on duty and sign-in, completing all information in the Visitor's Log, where applicable. The Vendor, sub-vendors and their employees shall sign-out after completion of the daily work activities. The Vendor, sub-vendors and their employees shall sign-in and sign-out when leaving and returning to the site (including when leaving/returning for breaks).

#### 4.8 Work Status

The Vendor shall keep the Department's Project/Contract Manager informed of the status of all work being performed throughout the duration of this Contract.

#### 4.9 Lighting, Water Source, and Power at the Site

- A. If the existing lighting at the site is not adequate, the Vendor shall be responsible for providing, at its sole expense, additional lighting necessary to perform the work required under this Contract. The Department will not be responsible for providing additional lighting that may be required to perform or inspect the work required under this Contract.

- B. If water is not available at the site or is not of sufficient volume or pressure, the Vendor shall be responsible for providing, at its sole expense, additional water necessary to perform the work required under this Contract.
- C. The Vendor and sub-vendors may use the Department’s electrical power outlets to power the tools utilized by the Vendor’s personnel or sub-vendors’ personnel to perform the work under this Contract. The amperage of the Vendor’s and sub-vendor’s tools should not exceed the allotted circuit amperage in the area work is being performed. The Vendor and sub-vendor shall verify the amperage at the time work is to begin and shall ensure the electrical demand for tool power supply will not overload the circuits.

4.10 Notification of Damages and Damage Repair

The Vendor shall notify the Department’s Project/Contract Manager verbally and/or by email of any damages to Turnpike Facilities or property of the traveling public as a result of the Vendor’s operations. The notification shall be completed during the next business day and include, at a minimum, the type of damage, location, nature of the incident, time and date of occurrence, photos and any related injuries. The Vendor shall, at its sole expense, repair all damages within twenty-four (24) hours of occurrence or at such other time approved by the Department’s Project/Contract Manager.

4.11 Clean-up and Disposal

The Vendor shall maintain all site and setup areas in a clean, neat and presentable condition. Upon completion of Vendor’s daily work activities, the Vendor shall collect and remove from the site all surplus, discarded materials and any other trash resulting from the work, and properly dispose of the same at a dumpsite approved for the disposal of each different type of material. Daily clean-up and disposal of materials shall be performed to the satisfaction of the Department’s Project/Contract Manager. All costs associated with clean-ups and disposals are incidental to this Contract and shall be included in the Vendor’s unit prices shown on the Exhibit “C,” Bid Blank.

4.12 Uniforms

The Vendor, sub-vendors and their employees, at all times, while at the site, shall wear uniforms clearly identifying the company logo and employee’s name.

4.13 Performance Measures

The Vendor will be expected to complete the work within the timeframe established in the Contract. Failure by Vendor to complete the work within the allowed timeframe may result in a deduction based on the following performance criteria;

<b>PERFORMANCE CRITERIA</b>		
<i>Deficiency Identification</i>	<i>Time Allowed/Criteria</i>	<i>Deduction</i>
a. Work not completed within allowed timeframe.	Work must be completed within timeframe established in this Contract.	1% of Contract amount per day late.
b. Work not completed correctly or according to requirements.	Re-perform the work until correct. Work must be completed according to requirements established in this Contract, procedures, specifications, and other Contract documents.	1% of Contract amount per day late due to exceeding allowed timeframe in re-performing the work.

All deductions withheld from the Vendor will occur through adjustments to the Vendor’s invoice(s).

#### 4.14 Subletting or Assigning of Work

The Vendor shall not sublet, assign or transfer any work under this Contract without prior written consent by the Department. Upon written consent by the Department, the Vendor will be permitted to sublet a portion of the work but shall perform with its own organization work amounting to not less than forty percent (40%) of the total Contract amount. All sub-vendors are required to be qualified and certified for the work they intend to perform in accordance with the requirements herein, all federal, state and local regulations, and approved by the Department. Subletting of work shall not relieve the Vendor of its respective liabilities. The Department recognizes a sub-vendor only in the capacity of an employee or agent of the Vendor. The Vendor, sub-vendors, or any of their employees shall not perform any work that is beyond their technical capabilities or for which they are not licensed or certified.

#### 4.15 Notice of Claim

Where the Vendor deems that additional compensation or a time extension is due for work or materials not expressly provided for in the Contract or which is by written directive expressly ordered by the Department, the Vendor shall notify the Department in writing of the intention to make a claim for additional compensation or a time extension before beginning the work on which the claim is based. Such notice by the Vendor shall not in any way be construed as establishing the validity of the claim. If such notice is not submitted to the Department within ten (10) calendar days after the Vendor first recognizes the condition giving rise to the claim, the Vendor hereby waives all right to any claim for additional compensation for such claim.

Rejection of the claim(s) by the Department does not absolve the Vendor of its obligations to meet the requirements in this Contract.

### 5.0 Safety and Worker Protection

#### 5.1 Safety and Worker Protection Requirements

- A. The Vendor shall be responsible for initiating, maintaining and supervising all safety precautions and programs in connection with the work. The Vendor shall provide the necessary protection for the safety of its employees, sub-vendors, sub-vendor's employees and the public to prevent damage, injury, or loss to:
- All employees at the site and other persons who may be affected thereby.
  - All the work and all materials, and/or equipment to be incorporated therein, whether in storage on or offsite.
  - Other property at the site or adjacent thereto, including trees, lawns, walkways, pavements, roadways, structures, and utilities.
- B. The Vendor shall assume full liability for compliance with all federal, state and local regulations pertaining to the protection of workers and persons occupying adjacent Turnpike Facilities.
- C. Any damages to the property of the traveling public and/or the Department as a result of the Vendor's work shall be the sole responsibility of the Vendor.
- D. The Vendor shall properly use and dispose of all chemicals and other hazardous materials in strict accordance with applicable local, state, and federal laws and regulations and shall indemnify the Department of any liabilities arising out of the Vendor's handling, use of, and disposal of said chemicals and hazardous materials.
- E. The Vendor's employees and sub-vendor's employees shall always wear safety vests (current Department approved) when working within the Department's Right of Way. Hard hats or safety helmet caps are to be used in areas of overhead hazards.

- F. The Vendor's vehicles/equipment shall have the company name and/or logo with amber strobe lights mounted on top of all vehicles/equipment. These lights shall be used only when required in the course of the work and shall not be used when traveling to and from each site.

#### 5.2 Delay of Work Due to Weather or Other Causes

- A. When the work is delayed or precluded from being done on schedule, by inclement weather, natural disaster, emergency condition, other work performed by Department personnel, or another Department Vendor, the Vendor shall reschedule the work and advise the Department's Project/Contract Manager of the change in schedule caused by the weather or any other cause for the delay, such as the example contained herein.
- B. In case of extreme traffic or weather conditions, the Vendor shall be required to remove their operation from the roadway and/or right of way at the discretion of the Department's Project/Contract Manager, the Florida Highway Patrol, or other law enforcement agency having jurisdiction over these roadways.

#### 5.3 Lock-out/Tag-out

The Vendor shall comply with the requirements outlined in OSHA Rule 29 CFR 1910.147. The strict compliance with the requirements of "lock-out/tag-out" is to prevent possible employee injury that may result from unexpected energizing or start-up of equipment while conducting maintenance or repair work. These requirements shall be implemented by the Vendor with no exceptions. The Department's Project/Contract Manager shall stop all work if "lock-out/tag-out" is not implemented. The Vendor shall be responsible for loss of time resulting from not following "lock-out/tag-out" procedures on the site and shall not reflect or change the time estimated by the Department's Project/Contract Manager on the work document. Additional hours of work will not be amended/revised for failure to comply with these procedures.

#### 5.4 U-Turns

No U-turns are permitted at median openings, maintenance gates, or such other openings that are intended for the use of emergency vehicles. U-turns shall only be permitted at service plazas or at the next available exit

### 6.0 The Department's Responsibilities

#### 6.1 Administration of Contract

All work under this Contract will be under the administration of the Department.

The Department will assign the Department's Project/Contract Manager to administer the terms and conditions of the Contract at the Pre-work Conference.

#### 6.2 Pre-work Conference

The Department will contact the Vendor and schedule a Pre-work Conference prior to the start date of the Contract to review the work involved and the requirements of the Contract.

#### 6.3 Periodic Inspection

The Department shall have the right to conduct periodic inspections of work performed and materials used to determine compliance with the requirements of this Contract. The Department's Project/Contract Manager shall have the right to inspect and reject any and all work and materials that does not meet with the requirements of the Contract. Any work or materials rejected by the Department shall be corrected at the Vendor's expense. Failure to reject defective work or materials, whether from lack of discovery or for any other reason, shall not relieve the Vendor from responsibility to complete the work in full compliance with all Contract requirements, and shall in no way prevent later rejection of such defective work or materials by the Department.

#### 6.4 Performance Evaluation

The Department shall conduct an evaluation of the Vendor's performance at the end of this Contract. The "Contractor Field Performance Report" shall be used for this purpose. The Vendor shall have an opportunity to review the report and make comments. The Vendor shall be required to sign the report acknowledging receipt of the performance evaluation.

#### 7.0 Duration of Contract

The Department will issue the NTP within sixty (60) calendar days after the Department's execution of the Contract. Services shall commence upon the start date identified in the NTP issued by the Department and shall be completed within sixty (60) calendar days thereafter.

**FLORIDA DEPARTMENT  
OF TRANSPORTATION**



**ATTACHMENTS**

**DOT-ITB-20-8025-AC**

**GENERATOR, FUEL TANK AND AUTOMATIC TRANSFER SWITCH (ATS) REPLACEMENT  
AT MID-BAY BRIDGE ADMINISTRATION BUILDING, SR 293, MILEPOST 5.0**

**FPID: 413878-1-93-11**



INDEX OF DRAWINGS	
SHEET No.	SHEET NAME
<b>GENERAL</b>	
G-001	COVER SHEET
G-002	SYMBOL LEGEND AND ABBREVIATIONS
<b>ARCHITECTURAL</b>	
AS101	ARCHITECTURAL SITE PLAN
A-101	PARTIAL DEMOLITION FLOOR PLAN AND PARTIAL FLOOR PLAN
<b>STRUCTURAL</b>	
S-001	GENERAL STRUCTURAL NOTES
S-101	STRUCTURAL PLAN
<b>MECHANICAL</b>	
M-001	GENERAL NOTES AND LEGEND
M-002	GENERAL CONSTRUCTION NOTES
MS101	OVERALL SITE PLAN
MD101	ENLARGED DEMOLITION FUEL TANK AND GENERATOR PLAN
M-101	ENLARGED FUEL TANK AND GENERATOR PLAN
M-501	GENERATOR DETAILS AND NOTES
M-502	FUEL TANK ANCHORING DETAILS
<b>ELECTRICAL</b>	
E-001	ELECTRICAL SYMBOL LEGEND, GENERAL NOTES AND WIRE SCHEDULE
ES101	OVERALL SITE PLAN
ED101	ENLARGED DEMOLITION FUEL TANK AND GENERATOR PLAN
E-101	ENLARGED FUEL TANK AND GENERATOR PLAN
M-601	EXISTING RISER DIAGRAM AND PANEL SCHEDULE

# STATE OF FLORIDA DEPARTMENT OF TRANSPORTATION

## DESIGN CRITERIA

413878-1-93-11

OKALOOSA COUNTY

SR 293

### MID-BAY BRIDGE ADMINISTRATION BUILDING GENERATOR AND FUEL TANK REPLACEMENT

### WHITE POINT ROAD

AUGUST 2nd, 2019

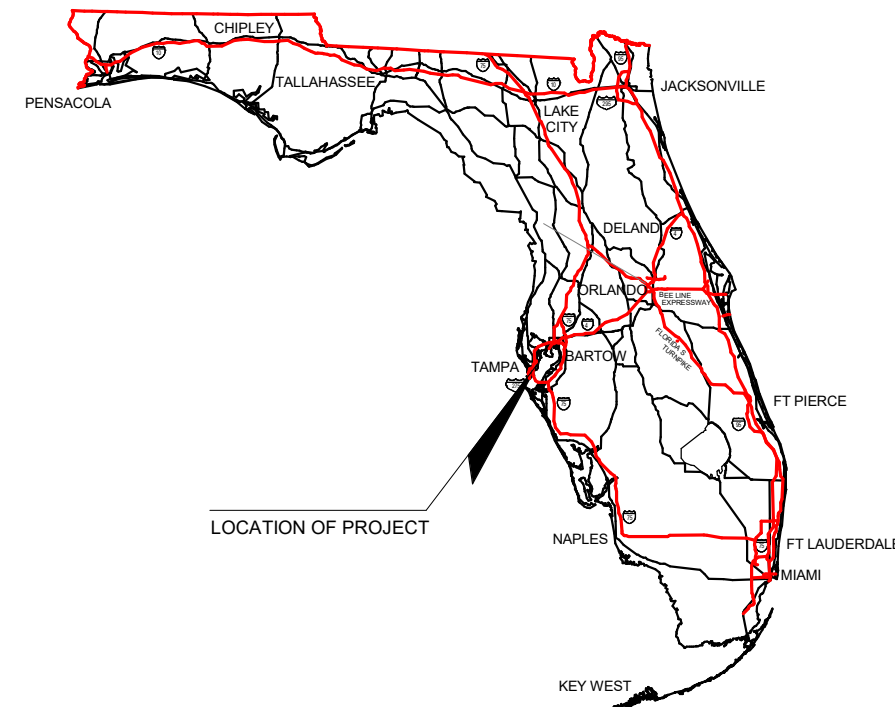

LOCATION OF PROJECT

SHOP DRAWINGS TO BE SUBMITTED TO:

JEFFREY N. WARMINGTON, AIA, NCARB  
REGISTERED ARCHITECT  
FLORIDA'S TURNPIKE ENTERPRISE / ATKINS  
MILEPOST 65  
P.O. BOX 9828  
FORT LAUDERDALE, FL 33310  
PHONE: (786) 251 3620

PLANS PREPARED BY:

ATKINS NORTH AMERICA, INC

800 WATERFORD WAY, SUITE 700  
MIAMI, FLORIDA 33126  
305.592.7275  
COA No.:AA000723 COA No.:24

**NOTE: THE SCALE OF THESE PLANS MAY HAVE CHANGED DUE TO REPRODUCTION**



MID-BAY BRIDGE ADMINISTRATION BUILDING



IF THESE DOCUMENTS ARE BEING TRANSMITTED OR REVIEWED BY COMPUTER OR OTHER ELECTRONIC MEANS, EACH DOCUMENT MUST BE COMPARED TO THE ORIGINAL HARD COPY WITH CERTIFIED RAISED SEAL IN ORDER TO INSURE THE ACCURACY OF THE INFORMATION CONTAINED THEREIN, AND TO FURTHER THAT NO CHANGES, ALTERATIONS OR MODIFICATIONS HAVE BEEN MADE TO THE DOCUMENT. NO RELIANCE SHOULD EVER BE MADE ON A DOCUMENT TRANSMITTED OR REVIEWED BY COMPUTER OR OTHER ELECTRONIC MEANS UNLESS IT IS FIRST COMPARED TO THE ORIGINAL.

GOVERNING STANDARDS AND SPECIFICATIONS:  
FLORIDA DEPARTMENT OF TRANSPORTATION, 2019 DESIGN STANDARDS AND 2019 STANDARD SPECIFICATIONS FOR ROAD AND BRIDGE CONSTRUCTION, AS AMENDED BY CONTRACT DOCUMENTS.

FDOT PROJECT MANAGER: SANTIAGO ALVAREZ  
ATKINS G.E.C. PROJECT MANAGER: JEFFREY N. WARMINGTON

KEY SHEET REVISIONS		
DATE	BY	DESCRIPTION

FISCAL YEAR	DRAWING No.
	G-001
19	SHEET No.
	1

**PROJECT : RENOVATION**  
**ISSUE DATE : AUGUST 2nd, 2019**

**ABBREVIATIONS**

A.F.F.	ABOVE FINISH FLOOR
A/C	AIR CONDITIONING
AL	ALUMINUM
CORR.	CORRIDOR
CONT.	CONTINUOUS
CU	CONDENSING UNIT
DIA.	DIAMETER
EA.	EACH
E.J.	EXPANSION JOINT
EL.	ELEVATION
ELEC.	ELECTRICAL
EXIST.	EXISTING
F.F.	FINISH FLOOR
F.V.	FIELD VERIFY
FT.	FEET
HT.	HEIGHT
H.M.	HOLLOW METAL
HR.	HOUR
IN	INCHES
INST.	INSTALLATION
JT.	JOINT
MFG.	MANUFACTURER
MAX.	MAXIMUM
MIN.	MINIMUM
MTL.	METAL
MP.	MILE POST
N/A	NOT APPLICABLE
N.I.C.	NOT IN CONTRACT
No.	NUMBER
O.C.	ON CENTER
O.D.	OUTSIDE DIAMETER
P.E.	PROFESSIONAL ENGINEER
PLAS.	PLASTIC
PLYWD.	PLYWOOD
PNL.	PANEL
PR.	PAIR
P/S	PRESTRESSED
P.T.	PRESSURE TREATED
R	RADIUS
R.A.	REGISTERED ARCHITECT
RD.	ROOF DRAIN
SCHED.	SCHEDULE
S.C.W.	SOLID CORE WOOD
SEC.	SECTION
SIM.	SIMILAR
S.F.	SQUARE FEET
SPECS.	SPECIFICATIONS
S.S.	STAINLESS STEEL
STRUCT.	STRUCTURE
TYP.	TYPICAL

**SYMBOL LEGEND**

	DRAWING TITLE REFERENCE
	DETAIL REFERENCE
	SECTION CUT
	INTERIOR ELEVATION MARK
	PARTITION TYPE
	DOOR NUMBER
	ROOM NAME AND NUMBER
	COLUMN LINE GRID DESIGNATION
	EXISTING TO BE REMOVED
	NEW WALL
	EXISTING WALL TO REMAIN
	BREAK LINE
	NORTH ARROW
	ELEVATION MARK

C:\Users\BROW7157\OneDrive Corp\OneDrive - Atkins Ltd\Desktop\Mid Bay\Mid-Bay Bridge Admin Bldg. Generator Replacement R2018.rvt

REVISIONS						ATKINS NORTH AMERICA, INC. 800 Waterford Way, Suite 700 Miami, Florida 33126 305.592.7275 FBPR Certificate of Authorization No.: 24	STATE OF FLORIDA DEPARTMENT OF TRANSPORTATION			PROJECT NAME: MID-BAY BRIDGE TOLL PLAZA DESIGN CRITERIA GENERATOR AND FUEL TANK REPLACEMENT	DRAWING NO. G-002
DATE	BY	DESCRIPTION	DATE	BY	DESCRIPTION		ROAD NO.	COUNTY	FINANCIAL PROJECT ID		SHEET TITLE: SYMBOL LEGEND AND ABBREVIATIONS
							S.R. 293	OKALOOSA	413878-1-93-11		

**PROJECT : RENOVATION**  
**ISSUE DATE : AUGUST 2nd, 2019**

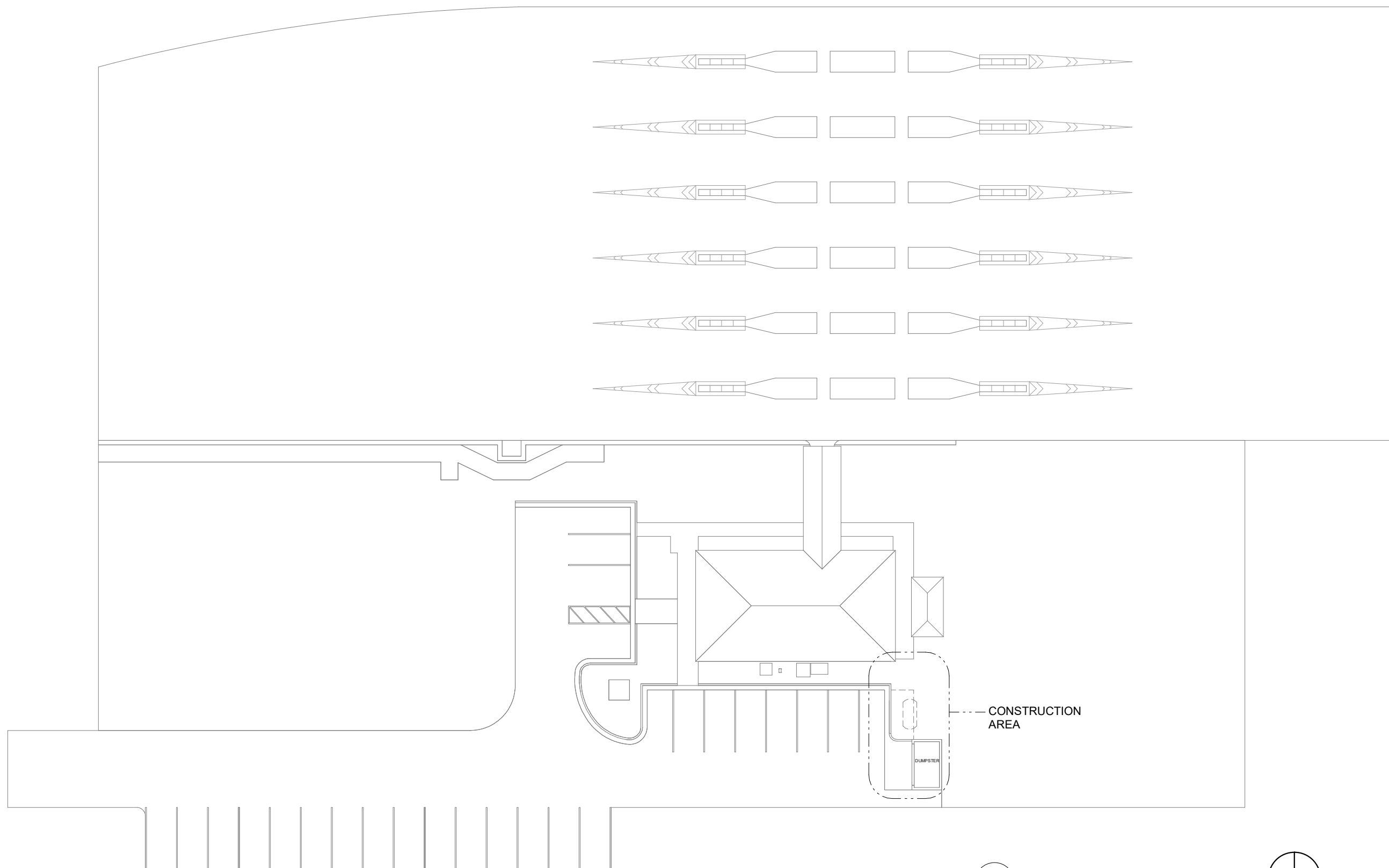

**1** ARCHITECTURAL SITE PLAN  
 AS101 SCALE: 1" = 30'-0" **N**

C:\Users\BROW7757\OneDrive Corp\OneDrive - Atkins Ltd\Desktop\Pompano\Mid Bay\Mid-Bay Bridge Admin Bldg. Generator Replacement R2018.rvt

REVISIONS					
DATE	BY	DESCRIPTION	DATE	BY	DESCRIPTION

**ATKINS NORTH AMERICA, INC.**  
 800 Waterford Way, Suite 700  
 Miami, Florida 33126  
 305.592.7275  
 FBPR Certificate of Authorization No.: 24

STATE OF FLORIDA DEPARTMENT OF TRANSPORTATION		
ROAD NO.	COUNTY	FINANCIAL PROJECT ID
S.R. 293	OKALOOSA	413878-1-93-11

PROJECT NAME: MID-BAY BRIDGE TOLL PLAZA DESIGN CRITERIA GENERATOR AND FUEL TANK REPLACEMENT
SHEET TITLE: ARCHITECTURAL SITE PLAN

DRAWING NO. <b>AS101</b>
SHEET NO. 3

**GENERAL NOTES**

- A. - ALL DIMENSIONS ARE TAKEN FROM FACE OF FINISH TO FACE OF FINISH UNLESS NOTED OTHERWISE.
- B. - PATCH AND REFINISH TO MATCH EXISTING ADJACENT WALL FINISH AFFECTED DUE TO DEMOLITION AND INSTALLATION OF NEW WORK.
- C. - FIELD VERIFY EXISTING DIMENSIONS AND CLEARANCES OF EXISTING STRUCTURES AND IN-GROUND UTILITIES PRIOR TO WORK.

**CONSTRUCTION NOTES**

- 1 NEW PAINTED ALUMINUM FIXED LOUVER SWING GATES MANUFACTURED BY AMETCO ARCHITECTURAL PRODUCTS OR APPROVED EQUAL. FIELD VERIFY DIMENSIONS BEFORE FABRICATION. SUBMIT SHOP DRAWING FOR ENCLOSURE AND COLOR SELECTION.
- 2 NEW PAINTED ALUMINUM FIXED LOUVER FENCE MANUFACTURED BY AMETCO ARCHITECTURAL PRODUCTS OR APPROVED EQUAL. SUBMIT SHOP DRAWING FOR ENCLOSURE AND COLOR SELECTION.
- 3 NEW CONCRETE SLAB. REFER TO STRUCTURAL DRAWINGS.
- 4 NEW MECHANICAL/ELECTRICAL EQUIPMENT. REFERENCE TO THOSE DISCIPLINES DRAWINGS FOR INFORMATION. COORDINATE PLACEMENT OF NEW FUEL TANK WITH REQUIRED DIMENSIONAL CLEARANCES.
- 5 PATCH ASPHALT TO MATCH EXISTING ADJACENT.
- 6 NEW ENCLOSURES AND GATES TO MATCH THE HEIGHT OF THE EXISTING DUMPSTER ENCLOSURE.
- 7 CLEAN AND REPAINT EXISTING METAL LOUVERS TO MATCH NEW FUEL TANK ENCLOSURE AND DUMPSTER GATES.



IMAGE OF PROPOSED GATE

**GENERAL NOTES**

- 1. CONTRACTOR SHALL VERIFY FIELD CONDITIONS AND DIMENSIONS BEFORE STARTING DEMOLITION AND CONSTRUCTION OF NEW WORK.
- 2. PRIOR TO COMMENCING DEMOLITION WORK, CONTRACTOR TO PROVIDE AND INSTALL A PROTECTIVE FENCE COVERING AROUND THE CONSTRUCTION AREA. ALL PROTECTIVE MEASURES INSTALLED SHALL BE TO THE SATISFACTION OF THE DEPARTMENT.

**DEMOLITION NOTES**

- 1 REMOVE EXISTING WOOD SWING GATES.
- 2 REFERENCE TO MECHANICAL AND ELECTRICAL DRAWINGS FOR DEMOLITION OF EQUIPMENT IN THIS AREA.
- 3 EXISTING CONCRETE CURB TO BE REMOVED.
- 4 EXISTING SLAB TO BE REMOVED.

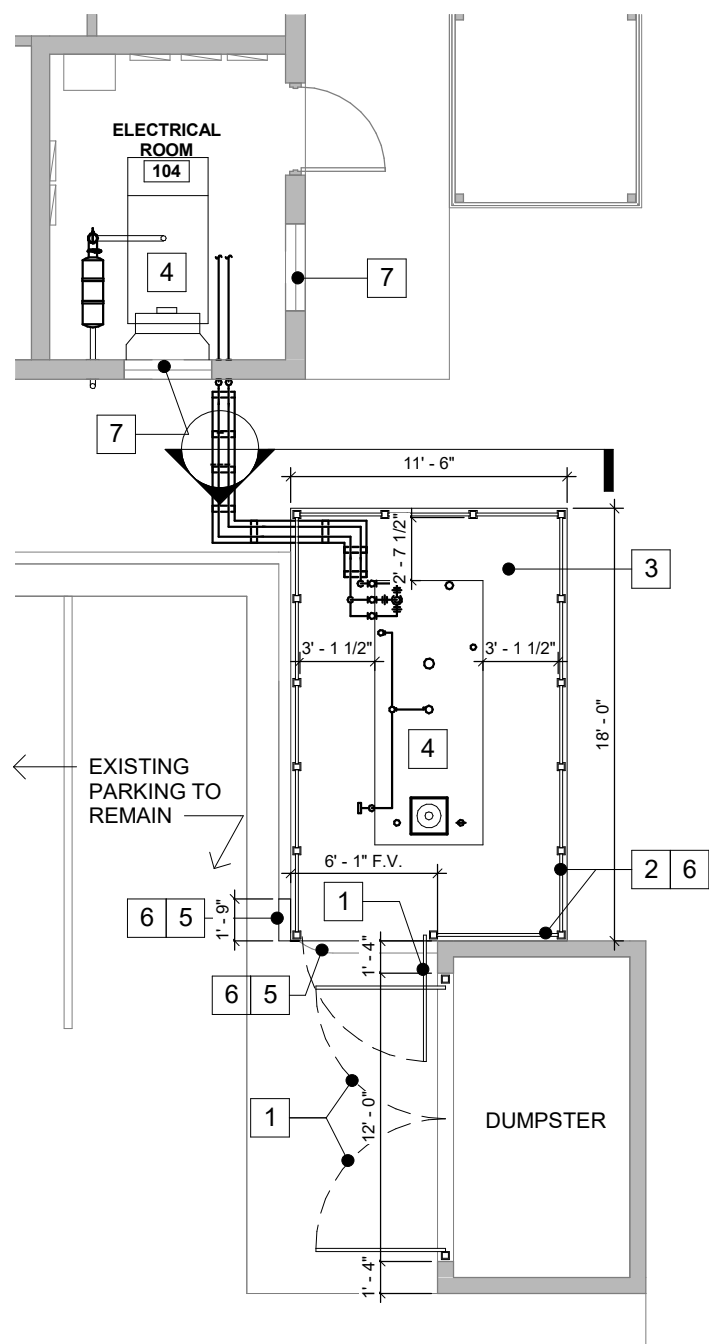

2 PARTIAL FLOOR PLAN  
A-101 SCALE: 1/8" = 1'-0"

GRAPHIC SCALE: 1/8" = 1'-0"

N

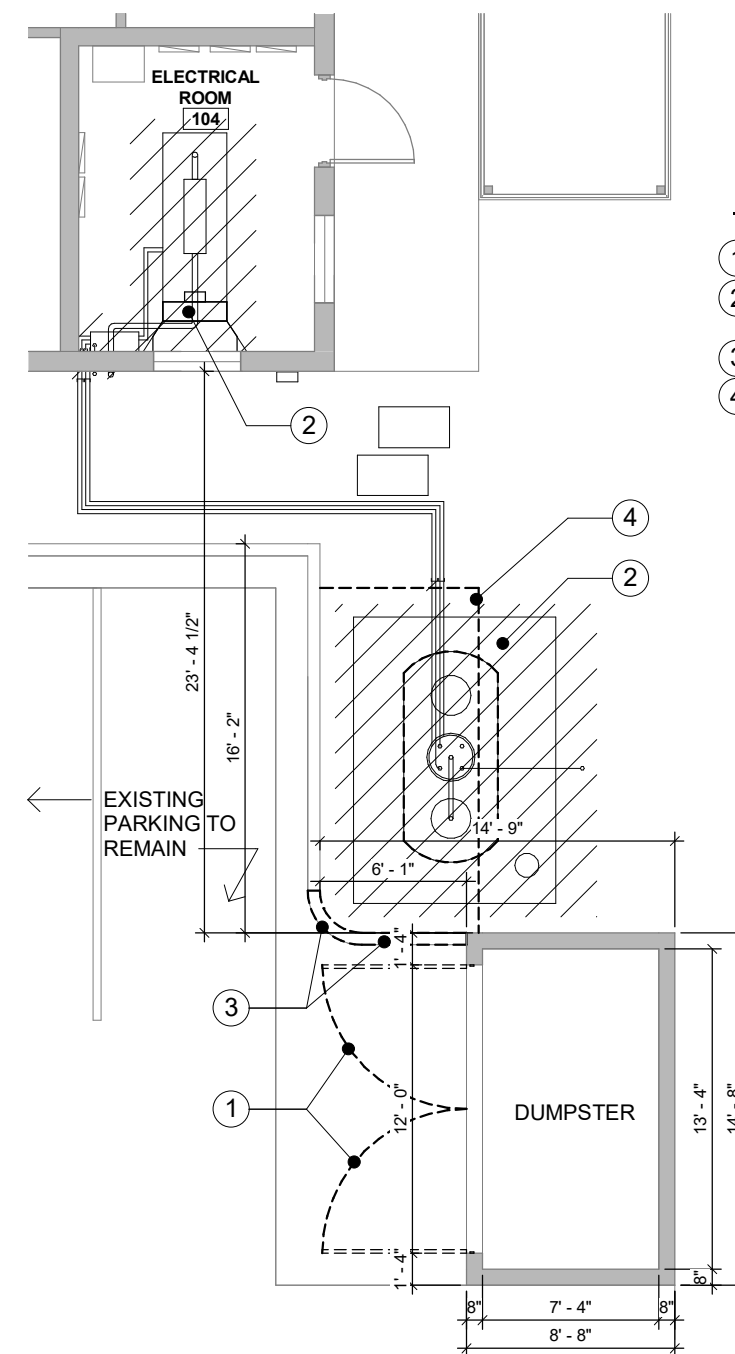

1 PARTIAL DEMOLITION FLOOR PLAN  
A-101 SCALE: 1/8" = 1'-0"

GRAPHIC SCALE: 1/8" = 1'-0"

N

C:\Users\BROW757\OneDrive - Atkins Ltd\Desktop\Pompano\Mid Bay\Mid-Bay Bridge Admin Bldg. Generator Replacement R2018.rvt

REVISIONS					
DATE	BY	DESCRIPTION	DATE	BY	DESCRIPTION

**ATKINS NORTH AMERICA, INC.**  
800 Waterford Way, Suite 700  
Miami, Florida 33126  
305.592.7275  
FBPR Certificate of Authorization No.: 24

<b>STATE OF FLORIDA DEPARTMENT OF TRANSPORTATION</b>		
ROAD NO.	COUNTY	FINANCIAL PROJECT ID
S.R. 293	OKALOOSA	413878-1-93-11

PROJECT NAME:  
MID-BAY BRIDGE TOLL PLAZA DESIGN CRITERIA  
GENERATOR AND FUEL TANK REPLACEMENT

SHEET TITLE:  
PARTIAL DEMOLITION FLOOR PLAN AND PARTIAL  
FLOOR PLAN

DRAWING NO. <b>A-101</b>
SHEET NO. 4

**PROJECT : RENOVATION**  
**ISSUE DATE : AUGUST 2nd, 2019**

**STRUCTURAL GENERAL NOTES:**

**A. BUILDING CODES:**

1. FLORIDA BUILDING CODE, 2017
2. ACI 318-14 BUILDING CODE REQUIREMENTS FOR REINFORCED CONCRETE.
3. AMERICAN INSTITUTE OF STEEL CONSTRUCTION (AISC) SPECIFICATION FOR THE DESIGN, FABRICATION, AND ERECTION OF STRUCTURAL STEEL FOR BUILDINGS, 13TH EDITION.
4. BUILDING CODE REQUIREMENTS FOR MASONRY STRUCTURES (ACI 530-08) AND SPECIFICATIONS FOR MASONRY STRUCTURES (ACI-530.1-08)

**B. DESIGN CRITERIA:**

1. BUILDING WIND LOADS AS PER ASCE 7-10  
 BUILDING CATEGORY: II  
 EXPOSURE "C"

**C. CONSTRUCTION MATERIALS:**

1. CAST-IN-PLACE CONCRETE COMPRESSIVE STRENGTH:  
 4000 PSI AT 28 DAYS (SLAB, FOUNDATION, EQUIPMENT PADS)
2. REINFORCING STEEL - ASTM A 615, GRADE 60 UNCOATED.
3. WELDING ELECTRODES - AWS E-70XX.
4. WELDED STEEL WIRE FABRIC - ASTM A 497
5. COLD-FORMED LIGHT-GAGE ROOF JOISTS SHALL BE 14 GAGE MINIMUM THICKNESS, 33KSI MIN, WITH MINIMUM MOMENT OF INERTIA (Ix) OF 3.524 IN^4. COLD FORMED CONNECTION CLIPS SHALL BE 33 KSI MIN.
6. STRUCTURAL STEEL
  - A. STRUCTURAL STEEL HAS BEEN DESIGNED IN ACCORDANCE WITH THE FBC AND AISC SPECIFICATIONS.
  - B. STRUCTURAL STEEL SHALL MEET THE FOLLOWING REQUIREMENTS UNLESS NOTED OTHERWISE ON THE DRAWINGS:

TYPE	ASTM	GRADE	fy
WIDE FLANGE (W SHAPE)	A36	-	36KSI
C, S&M SHAPES	A36	-	36KSI
ANGLES	A36	-	36KSI
SQUARE & RECTANGULAR HSS	A500	B	46KSI
ROUND HSS	A500	B	42KSI
STEEL PIPE	A53	-	35KSI
STRUCTURAL BOLTS	ASTM1554	36	36KSI
ANCHOR BOLTS-THREADED RODS	F1554	36	36KSI
PLATES	A36		36KSI
THREADED RODS	A36		36KSI

ALL STRUCTURAL STEEL THAT IS EXPOSED TO THE WEATHER SHALL BE HOT DIPPED GALVANIZED.

- C. ALL CONNECTIONS NOT DETAILED OR OTHERWISE NOTED SHALL BE DESIGNED BY THE FABRICATOR. SHOP DRAWINGS AND CONNECTION CALCULATIONS SHALL BE SUBMITTED BEARING THE SEAL OF AN ENGINEER REGISTERED IN THE STATE OF FLORIDA.
- D. BEAM SHEAR CONNECTIONS DESIGN SHALL BE BASED ON BEARING TYPE BOLTED CONNECTIONS WITH BOLTS "SNUG TIGHT" PER AISC.
- E. WELDING:
 

CONNECTIONS SHOWN ARE BASED ON WELD MADE WITH E70XX ELECTRODES. WELDING TO BE DONE BY CERTIFIED WELDERS HOLDING CURRENT WELDING CERTIFICATES, AND MUST PRESENT SAME AT JOB SITE AT ALL TIMES. ALL WELDING PER PLANS AND PER GUIDELINES OF THE AMERICAN WELDING SOCIETY.
7. ANCHOR BOLTS SHALL BE GALVANIZED
8. MASONRY CONSTRUCTION AND MATERIALS SHALL CONFORM TO ALL REQUIREMENTS OF SPECIFICATIONS FOR MASONRY STRUCTURES PUBLISHED BY ACI EXCEPT AS MODIFIED BY REQUIREMENTS OF THE TECHNICAL SPECIFICATIONS.
9. ALL MASONRY SHALL BE LOAD-BEARING NORMAL WEIGHT CMU CONFORMING TO ASTM C90, GRADE N, TYPE II. ALL MORTAR SHALL CONFORM TO ASTM C270, TYPE S, EXCEPT USE TYPE M BELOW GRADE.
10. MINIMUM COMPRESSIVE STRENGTH OF MASONRY SHALL BE F'm=1500 PSI.  
 NET AREA COMPRESSIVE STRENGTH OF CMU WITH TYPE M OR MORTAR=1900 PSI.
11. ALL MASONRY IN THIS PROJECT SHALL BE GROUT-FILLED SOLID.

**D. FOUNDATIONS:**

1. FILL AND BACKFILL TO BE COMPACTED TO 95% OF MAXIMUM DRY DENSITY FOR ALL LAYERS AS VERIFIED BY FIELD DENSITY TEST FOR ALL LAYERS. TESTS SHALL BE MADE IN ACCORDANCE WITH METHODS OF TEST FOR MOISTURE DENSITY RELATIONS OF SOILS, ASTM D 1557 MODIFIED. COMPACTION LAYERS NOT TO EXCEED 12". BACKFILL MATERIAL TO BE APPROVED BY SOIL ENGINEER. SLABS TO BE PLACED CONTINUOUSLY. PROVIDE VAPOR BARRIER BELOW ALL SLABS ON FILL (10 MIL.).

**E. GENERAL NOTES:**

1. ALL CONCRETE EMBEDDED STEEL ANGLES, WELD PLATES, ANCHORAGE DEVICES, ETC., SHALL BE GALVANIZED IN ACCORDANCE WITH ASTM A 123 AND / OR F 2329.
2. ALL REINFORCEMENT TO BE DETAILED AND FABRICATED IN ACCORDANCE WITH ACI 315-94 ALL CONSTRUCTION JOINTS, WITH REINFORCING PASSING THROUGH THE JOINT, SHALL BE ROUGHENED TO A FULL AMPLITUDE OF APPROXIMATELY 1/8" INCH, UNLESS NOTED OTHERWISE.
3. PROVIDE THE FOLLOWING MINIMUM CONCRETE COVER, UNLESS NOTED OTHERWISE ON THE PLANS:  
 FOOTINGS ----- 3"  
 SLABS ON GRADE ----- UPPER 3RD OF SLAB OR 2"; WHICHEVER IS CLOSER TO TOP OF SLAB WALLS ----- 3/4"  
 INTERIOR COLUMNS & BEAMS ----- 1 1/2"  
 COLUMNS AND BEAMS EXPOSED TO WEATHER ----- 2"  
 ANY CONCRETE CAST AGAINST EARTH ----- 3"
4. VERIFY AND CORRELATE ALL DIMENSIONS BEFORE PROCEEDING WITH FABRICATION AND CONSTRUCTION.
5. CHAMFER ALL EXPOSED CONCRETE EDGES 3/4"x3/4", EXCEPT AS NOTED OTHERWISE.
6. ALL DIMENSIONS ARE MEASURED HORIZONTALLY OR VERTICALLY UNLESS NOTED OTHERWISE.

**F. COORDINATION:**

1. COORDINATE ALL MECHANICAL AND CONDUIT PENETRATIONS THROUGH CONCRETE WITH THE CIVIL, MECHANICAL, AND ELECTRICAL SHOP DRAWINGS PRIOR TO PLACING CONCRETE.
2. THE STRUCTURAL SHEETS SHALL BE COORDINATED WITH THE CIVIL, ARCHITECTURAL, MECHANICAL, AND ELECTRICAL SHEETS TO PROPERLY LOCATE PIPE SLEEVES, BLOCK-OUTS, ETC. DISCREPANCIES SHALL BE BROUGHT TO THE ATTENTION OF THE ENGINEER BEFORE PROCEEDING WITH THE WORK.
3. THE STRUCTURAL SHEETS SHALL BE COORDINATED WITH THE STANDARD SPECIFICATIONS, SUPPLEMENTS, AND TECHNICAL SPECIAL PROVISIONS.

**G. DEWATERING**

1. EXPECT TO PERFORM DEWATERING FOR FOUNDATIONS. THE CONTRACTOR SHALL TAKE ALL NECESSARY PRECAUTIONS TO PREVENT THE FLOTATION OF STRUCTURES UNTIL ALL BACKFILL IS PROPERLY COMPACTED IN PLACE AND CONSTRUCTION IS COMPLETE.

**H. SUBMITTALS**

1. THE FOLLOWING ITEMS SHALL BE SUBMITTED FOR REVIEW:
  1. CONCRETE MIX DESIGNS
  2. REINFORCING STEEL

**SOIL STATEMENT:**

FOUNDATION SYSTEM HAS BEEN DESIGNED USING A PRESUMPTIVE LOAD-BEARING CAPACITY OF 2000 PSF. THE SOIL COMPOSITION AT THE SITE CONSISTS OF LIMEROCK MIXED WITH SANDY MATERIAL.

P:\TPK\2013\0000000000\_Mid-Bay Bridge Toll Plaza\000000000000\_Mid-Bay Admin Bldg, Generator and Fuel Tank Replace\01\_CAD-BIM\02\_DWG\SHHEET\03\_struct\S-001.dwg

REVISIONS						<b>ATKINS NORTH AMERICA, INC.</b> 800 Waterford Way, Suite 700 Miami, Florida 33126 305.592.7275 FBPR Certificate of Authorization No.: 24	STATE OF FLORIDA DEPARTMENT OF TRANSPORTATION			MID-BAY BRIDGE TOLL PLAZA DESIGN CRITERIA GENERATOR AND FUEL TANK REPLACEMENT	DRAWING NO.
DATE	BY	DESCRIPTION	DATE	BY	DESCRIPTION		ROAD NO.	COUNTY	FINANCIAL PROJECT ID		S-001
							SR 293	OKALOOSA	413878-1-93-11		SHEET NO.
						<b>GENERAL STRUCTURAL NOTES</b>			5		

PROJECT : RENOVATION  
 ISSUE DATE : AUGUST 2nd, 2019

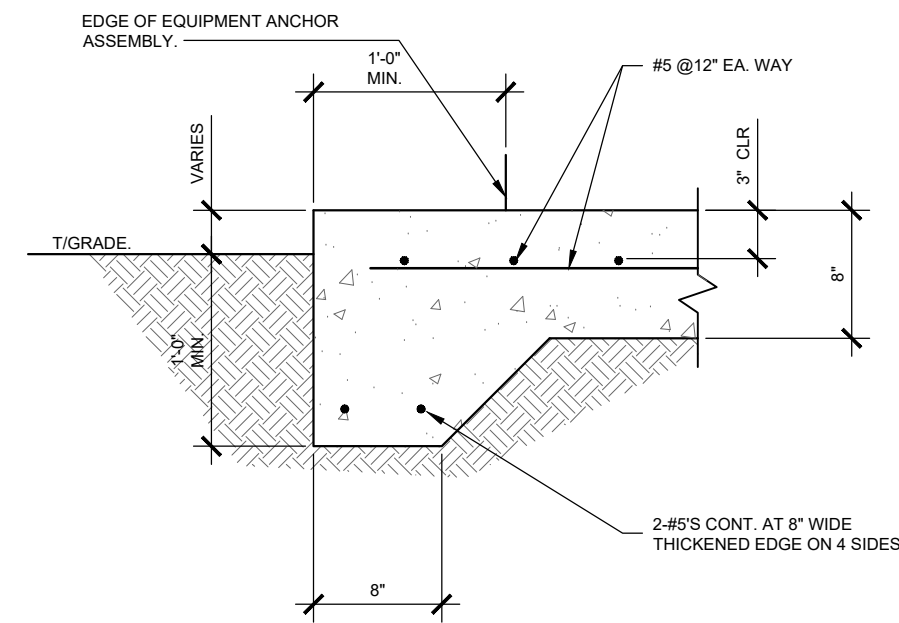
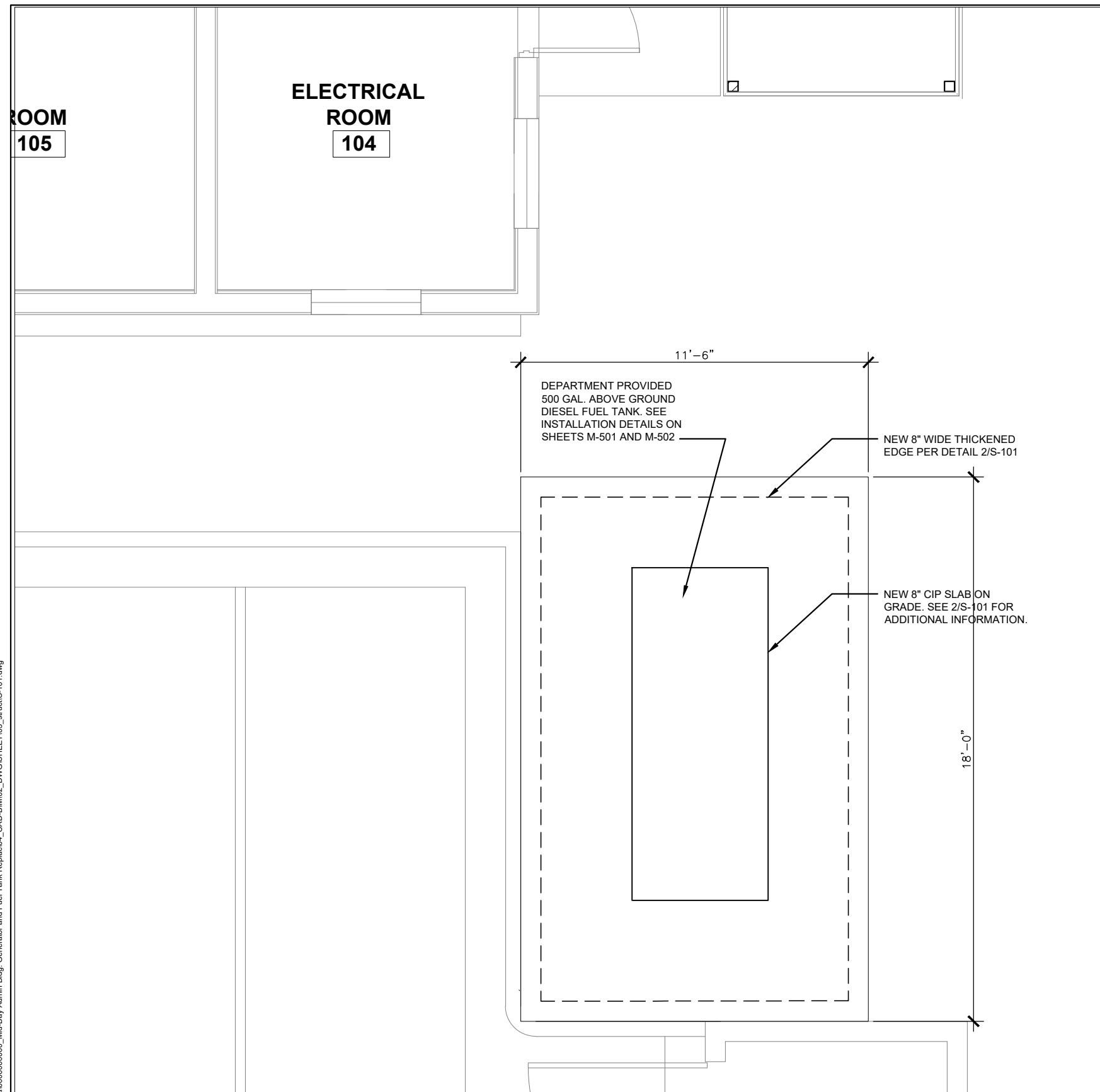

2 SLAB DETAIL  
 S-101 SCALE: N.T.S.

1 FOUNDATION PLAN  
 S-101 SCALE: 3/16"=1'-0"

P:\TPK\2013\0000000000\_Mid-Bay Bridge Toll Plaza\0000000000\_Mid-Bay Admin Bldg. Generator and Fuel Tank Replace01\_CAD-BIM\02\_DWG\SHEET\03\_struct\S-101.dwg









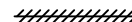

REVISIONS						<b>ATKINS NORTH AMERICA, INC.</b> 800 Waterford Way, Suite 700 Miami, Florida 33126 305.592.7275 FBPR Certificate of Authorization No.: 24	STATE OF FLORIDA DEPARTMENT OF TRANSPORTATION			MID-BAY BRIDGE TOLL PLAZA DESIGN CRITERIA GENERATOR AND FUEL TANK REPLACEMENT		DRAWING NO.
DATE	BY	DESCRIPTION	DATE	BY	DESCRIPTION		ROAD NO.	COUNTY	FINANCIAL PROJECT ID	STRUCTURAL PLAN		SHEET NO.
							SR 293	OKALOOSA	413878-1-93-11			6

**PROJECT : RENOVATION**  
**ISSUE DATE : AUGUST 2nd, 2019**

**GENERAL MECHANICAL / FUEL NOTES**

1. CONTRACTOR SHALL PROVIDE CONSTRUCTION DOCUMENTS SIGNED AND SEAL BY A FLORIDA REGISTERED ENGINEER. ALONG WITH THE CONSTRUCTION DOCUMENTS THE WORK SHALL INCLUDING ALL LABOR, MATERIALS, AND EQUIPMENT FOR FUELING SYSTEMS COMPLETE INCLUDING, CONTROLS, CONTROL PROGRAMING, CONTROL WIRING, GALVANIZED SHEET METAL PLENUMS AND ALL FITTINGS, SPECIALTIES, ANCHORING/SUPPORTING OF EQUIPMENT, AUXILIARY MATERIALS AND ACCESSORIES AS SHOWN ON THE CRITERIA DRAWINGS AND SPECIFIED HEREIN.
2. IT SHALL BE THE RESPONSIBILITY OF THE CONTRACTOR TO VISIT THE SITE OF THE WORK AND BECOME FAMILIAR WITH ALL AVAILABLE INFORMATION REGARDING THE LOCATION OF EXISTING FACILITIES. FAILURE OF THE CONTRACTOR TO FULLY INFORM HIMSELF OF ALL EXISTING CONDITIONS WILL NOT BE CAUSE FOR ADDITIONAL COMPENSATION.
3. ALL EQUIPMENT AND MATERIALS USED IN THIS INSTALLATION SHALL BE NEW, OF APPROVED QUALITY AND MANUFACTURE AND, UNLESS OTHERWISE NOTED, SHALL BE STANDARD CATALOG ITEMS OF THE VARIOUS MANUFACTURERS. EACH COMPONENT OF THE WORK SHALL BE COMPLETE, CONNECTED AND CAPABLE OF SATISFACTORY FUNCTIONAL OPERATION.
4. FOLLOW REQUIREMENTS OF THE FLORIDA BUILDING CODES, REGULATIONS, ORDINANCES, ETC., OF THE STATE, COUNTY, AND/OR MUNICIPALITY, IN WHICH THE CONSTRUCTION IS LOCATED, AND ANY GOVERNMENT ENTITY HAVING JURISDICTION OVER THIS WORK.
5. ALL EQUIPMENT SHALL FIT THE ALLOTTED SPACE AND SHALL LEAVE REASONABLE ACCESS ROOM FOR SERVICING AND REPAIRS. GREATER SPACE AND ROOM REQUIRED BY SUBSTITUTED EQUIPMENT SHALL BE PROVIDED BY THE CONTRACTOR AND AT HIS EXPENSE AND MEETING THE APPROVAL OF THE CONSTRUCTION MANAGER.
6. IF THE CONTRACTOR DISCOVERS ANY DISCREPANCIES BETWEEN EQUIPMENT DIMENSIONS AND SPACE ALLOTMENTS THEREFORE; HE/SHE SHALL NOTIFY THE CONSTRUCTION MANAGER IN WRITING AND SHALL NOT PROCEED WITH THE WORK UNTIL HE HAS RECEIVED WRITTEN INSTRUCTIONS FROM THE CONSTRUCTION MANAGER.
7. THE CONTRACTOR SHALL DO NO CUTTING THAT MAY IMPAIR STRENGTH OF BUILDING CONSTRUCTION. NO HOLES, EXCEPT FOR SMALL SCREWS, MAY BE DRILLED IN BEAMS, DOUBLE-TEES OR OTHER STRUCTURAL MEMBERS WITHOUT OBTAINING PRIOR APPROVAL OF THE CONSTRUCTION MANAGER.
8. CUTTING AND PATCHING - UNLESS OTHERWISE INDICATED, PERFORM ALL CUTTING AND PATCHING NECESSARY FOR THE WORK. PATCH AND PAINT AFFECTED AREAS TO MATCH EXISTING CONDITIONS INCLUDING MATERIAL OF CONSTRUCTION. WHERE INTERFERENCES OCCUR, AND DEPARTURES FROM INDICATED ARRANGEMENTS ARE REQUIRED, COORDINATE THE MECHANICAL/ELECTRICAL/STRUCTURAL WORK WITH THE OTHER TRADES INVOLVED AND MAKE A DETERMINATION AS TO CHANGES AND SHALL OBTAIN APPROVAL FROM THE DEPARTMENT FOR THE PROPOSED CHANGES.
9. THE CONTRACTOR SHALL FURNISH ALL ELECTRICAL WORK ASSOCIATED WITH MECHANICAL/FUEL SYSTEM EQUIPMENT, INCLUDING ELECTRICAL CONTROLS, SWITCHES, CONTACTORS AND STARTERS FOR ALL EQUIPMENT ITEMS REQUIRING SAME. ALL ELECTRICAL WORK SHALL CONFORM IN ALL RESPECTS TO THE REQUIREMENTS OF THE CURRENT NATIONAL ELECTRICAL CODE.
10. UNLESS OTHERWISE INDICATED, METAL FASTENERS AND RELATED PARTS SHALL BE OF ALUMINUM OR STAINLESS STEEL AND SHALL BE OF ADEQUATE STRENGTH FOR THE PURPOSE INTENDED.
11. LEAVE CONCEALED WORK UNCOVERED UNTIL REQUIRED TESTS HAVE BEEN COMPLETED, BUT IF NECESSARY TO MAKE TESTS ON PORTIONS OF THE WORK, THOSE PORTIONS OF THE WORK MAY BE CONCEALED AFTER BEING INSPECTED AND APPROVED. REPAIR DEFECTS THAT ARE DISCOVERED AS A RESULT OF INSPECTIONS OR TESTS WITH NEW MATERIALS. CAULKING, PEELING OR SOLDERING OF SCREWED JOINTS, CRACKS, OR HOLES WILL NOT BE ACCEPTED. REPEAT TESTS AFTER DEFECTS HAVE BEEN CORRECTED.
12. VERIFY ALL SPACE CONDITIONS AT JOB SITE PRIOR TO FABRICATION OF PIPING AND PURCHASE OF EQUIPMENT. NOTIFY ENGINEER OF ANY SPATIAL CONFLICTS THAT COULD AFFECT THE PROJECT. DO NO WORK UNTIL ALL CONFLICTS ARE RESOLVED. BEGINNING OF INSTALLATION WILL BE CONSTRUED AS ACCEPTANCE OF SPATIAL CONDITIONS.
13. VERIFY ALL CONNECTION TO EQUIPMENT WITH MANUFACTURER'S CERTIFIED DRAWINGS. DO NOT SCALE DRAWINGS. PROVIDE TRANSITIONS TO ALL EQUIPMENT AS REQUIRED.
14. COORDINATE PIPING WITH OTHER DISCIPLINES PRIOR TO FABRICATION AND INSTALLATION. PROVIDE ANY OFFSETS AND TRANSITIONS TO COORDINATE WITH OTHER TRADES AS REQUIRED. PIPING IS SHOWN DIAGRAMMATICALLY AND SHALL BE ADJUSTED AS REQUIRED TO SUIT EXISTING OR FIELD CONDITIONS.
15. COORDINATE AVAILABLE ELECTRICAL CHARACTERISTICS AT JOB SITE WITH MECHANICAL/FUEL SYSTEM EQUIPMENT'S ELECTRICAL REQUIREMENTS PRIOR TO SUBMITTING SHOP DRAWINGS AND ORDERING EQUIPMENT.
17. ALL EQUIPMENT, PIPING, ETC., SHALL BE SUPPORTED AS DETAILED AND/OR SPECIFIED. PROVIDE ADDITIONAL SUPPORTS AS REQUIRED TO PROVIDE A VIBRATION-FREE, RIGID INSTALLATION.
19. WARRANTY
  - A. CONSTRUCTION AND PROJECT SCOPE: PROVIDE ONE YEAR WARRANTY FOR PARTS AND LABOR.  
EQUIPMENT : PROVIDE ONE YEAR MANUFACTURERS WARRANTY FOR PARTS AND LABOR.
20. RECORD DRAWINGS / AS-BUILT DOCUMENTATION
  - A. RECORD DRAWINGS SHALL BE SUBMITTED TO THE DEPARTMENT BEFORE FINAL ACCEPTANCE AND SHALL INCLUDE THE FOLLOWING AS A MINIMUM REQUIREMENT:
    1. EQUIPMENT SCHEDULES SHALL REFLECT ALL CHANGES IN THE APPROVED EQUIPMENT THAT DEVIATE FROM THE SCHEDULES AND SHALL INCLUDE THE MANUFACTURER'S NAME, MODEL NUMBER, PERFORMANCE CAPACITIES AND ACCESSORIES.
    2. INCORPORATION OF FIELD AS-BUILT RED LINES REFLECTING DEVIATIONS FROM CONSTRUCTION DOCUMENT'S ORIGINAL DESIGN.
21. FEES, PERMITS AND INSPECTIONS
  - A. THE DEPARTMENT SHALL PAY FOR ALL PERMITS AND APPLICATION FEES FOR WORK UNDER THIS CONTRACT.
  - B. THE CONTRACTOR SHALL COMPLETE ALL PERMIT APPLICATIONS AND DOCUMENTATION AS REQUIRED BY THE AUTHORITIES HAVING JURISDICTION. OBTAIN ALL PERMITS THAT ARE PAID FOR BY THE DEPARTMENT FOR WORK UNDER THIS CONTRACT. PROCURE AND DELIVER TO THE ENGINEER ALL CERTIFICATES ISSUED BY THE AUTHORITIES HAVING JURISDICTION. THE CONTRACTOR SHALL PAY FOR ALL PERMIT INSPECTIONS AND ASSOCIATED REVIEWS FOR WORK UNDER THIS CONTRACT.
  - C. THE WORK WILL BE OBSERVED BY THE DEPARTMENT DURING THE COURSE OF CONSTRUCTION. PROVIDE FOR INSPECTION BY OTHERS HAVING JURISDICTION DURING THE PROPER PHASES.
22. TESTS AND INSPECTIONS
  - A. INCLUDE ALL TESTS AND INSPECTIONS SPECIFIED AND/OR REQUIRED UNDER LAWS, RULES AND REGULATIONS OF ALL DEPARTMENTS HAVING JURISDICTION. TESTS SHALL BE PERFORMED AS INDICATED HEREIN AND OTHER SECTIONS OF SPECIFICATIONS.
23. ACCEPTANCE INSPECTION
  - A. REPRESENTATIVES OF INSTALLERS RESPONSIBLE FOR WORK UNDER THIS DIVISION SHALL BE PRESENT AT TIME OF ACCEPTANCE INSPECTIONS AND SHALL FURNISH REQUIRED MECHANICS, TOOLS, AND LADDERS TO ASSIST IN THE INSPECTION.
  - B. AS A PRECEDENT TO REQUESTING A FINAL INSPECTION, THE FOLLOWING STEPS SHALL BE MET: COMPLETE ALL WORK UNDER THIS SECTION OF THE SPECIFICATIONS.
    1. FURNISH THE ENGINEER WITH LETTER FROM AN AUTHORIZED REPRESENTATIVE OF THE EQUIPMENT MANUFACTURER CERTIFYING THAT ALL WORK HAS BEEN CHECKED FOR OPERATION AND CALIBRATION AND THAT THE SYSTEM IS OPERATING AS INTENDED.
  - C. A LIST OF ITEMS TO BE CORRECTED AS A RESULT OF ACCEPTANCE INSPECTION WILL BE FURNISHED TO THE INSTALLER. NOTIFY ENGINEER IN WRITING OF ANY ITEMS APPEARING ON LIST OF CORRECTION THAT ARE DISPUTED BY INSTALLER. WHEN READY, REQUEST IN WRITING A RE-INSPECTION OF WORK.
  - D. PROVIDE CERTIFICATION THAT ALL WORK IS IN CONFORMANCE WITH ALL CODES AND STANDARDS BY THE GOVERNING AGENCIES HAVING JURISDICTION OF THE WORK.
24. OPERATIONS AND PHASING
  - A. THIS FACILITY OPERATES 24 HOURS A DAY. THE CONTRACTOR SHALL SCHEDULE ALL WORK TO MINIMIZE ANY POWER DOWN TIME. IN THE EVENT THAT THE POWER IS INTERRUPTED, THE CONTRACTOR SHALL PROVIDE TEMPORARY GENERATOR AS REQUIRED TO MAINTAIN THE FACILITY FULLY OPERATIONAL FOR THE DURATION OF THIS PROJECT.
  - B. ALL SHUT DOWNS, WORK ABOVE STAFF, OPERATIONS INTERRUPTIONS AND CONSTRUCTION PHASING SHALL BE SUBMITTED IN WRITING FOR APPROVAL 7 DAYS IN ADVANCE THROUGH THE DEPARTMENT'S CONSTRUCTION MANAGER.
25. NOTIFY THE ENGINEER AT LEAST 72 HOURS IN ADVANCE OF ALL TESTS. FURNISH ALL NECESSARY INSTRUMENTS, GAUGES AND OTHER EQUIPMENT REQUIRED FOR TESTS. MAKE PRELIMINARY TESTS PRIOR TO GIVING NOTICE OF FINAL TESTS.
26. ALL PARTS OF THE WORK AND ASSOCIATED EQUIPMENT SHALL BE TESTED AND ADJUSTED TO WORK PROPERLY AND BE LEFT IN PERFECT OPERATING CONDITION.
27. CORRECT DEFECTS DISCLOSED BY THESE TESTS WITHOUT ANY ADDITIONAL COST TO THE DEPARTMENT. REPEAT TESTS ON REPAIRED OR REPLACED WORK.
28. MAINTAIN SEPARATE LOG OF ALL TESTS BEING CONDUCTED AND HAVE IT AVAILABLE FOR REVIEW BY ENGINEER. LOG TO INDICATE DATE, TYPE OF TESTS, DURATION AND DEFECTS NOTED AND WHEN CORRECTED.
29. THE BUILDING INSPECTION/PERMITTING AGENCY SHALL PERFORM ACCEPTANCE AND INSPECTION OF MECHANICAL/FUEL SYSTEMS. IN ADDITION, OBTAIN FINAL ACCEPTANCE OF MECHANICAL AND FUEL SYSTEMS FROM THE DEPARTMENT'S REPRESENTATIVE.

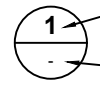
**LEGEND**

	EXISTING EQUIPMENT/PIPING TO BE REMOVED
	PIPE TURNING DOWN
	PIPE TURNING UP
	BALL VALVE
	UNION
ETR	EXISTING TO REMAIN
ETBR	EXISTING TO BE REMOVED
	KEYED NOTE. REFERS TO CONSTRUCTION NOTES.
	SECTION LETTER
	SECTION SYMBOL
	SHEET WHERE SECTION IS SHOWN
	DETAIL NUMBER
	DETAIL SYMBOL
	SHEET WHERE DETAIL IS SHOWN

P:\TPK 2013\000000000\_Mid-Bay Bridge Toll Plaza\000000000000\_Mid-Bay Admin Bldg Generator and Fuel Tank Replace\04\_CAD-BIM\02\_DWG\01SHEET\05\_Mech\01\_GENERAL NOTES AND LEGEND.dwg

REVISIONS						<b>ATKINS NORTH AMERICA, INC.</b> 800 Waterford Way, Suite 700 Miami, Florida 33126 305.592.7275 FBPR Certificate of Authorization No.: 24	STATE OF FLORIDA DEPARTMENT OF TRANSPORTATION			MID-BAY BRIDGE TOLL PLAZA DESIGN CRITERIA GENERATOR AND FUEL TANK REPLACEMENT		DRAWING NO.
DATE	BY	DESCRIPTION	DATE	BY	DESCRIPTION		ROAD NO.	COUNTY	FINANCIAL PROJECT ID	GENERAL NOTES AND LEGEND		M-001
							SR 293	OKALOOSA	413878-1-93-11			SHEET NO.
											7	







**PROJECT : RENOVATION**  
**ISSUE DATE : AUGUST 2nd, 2019**

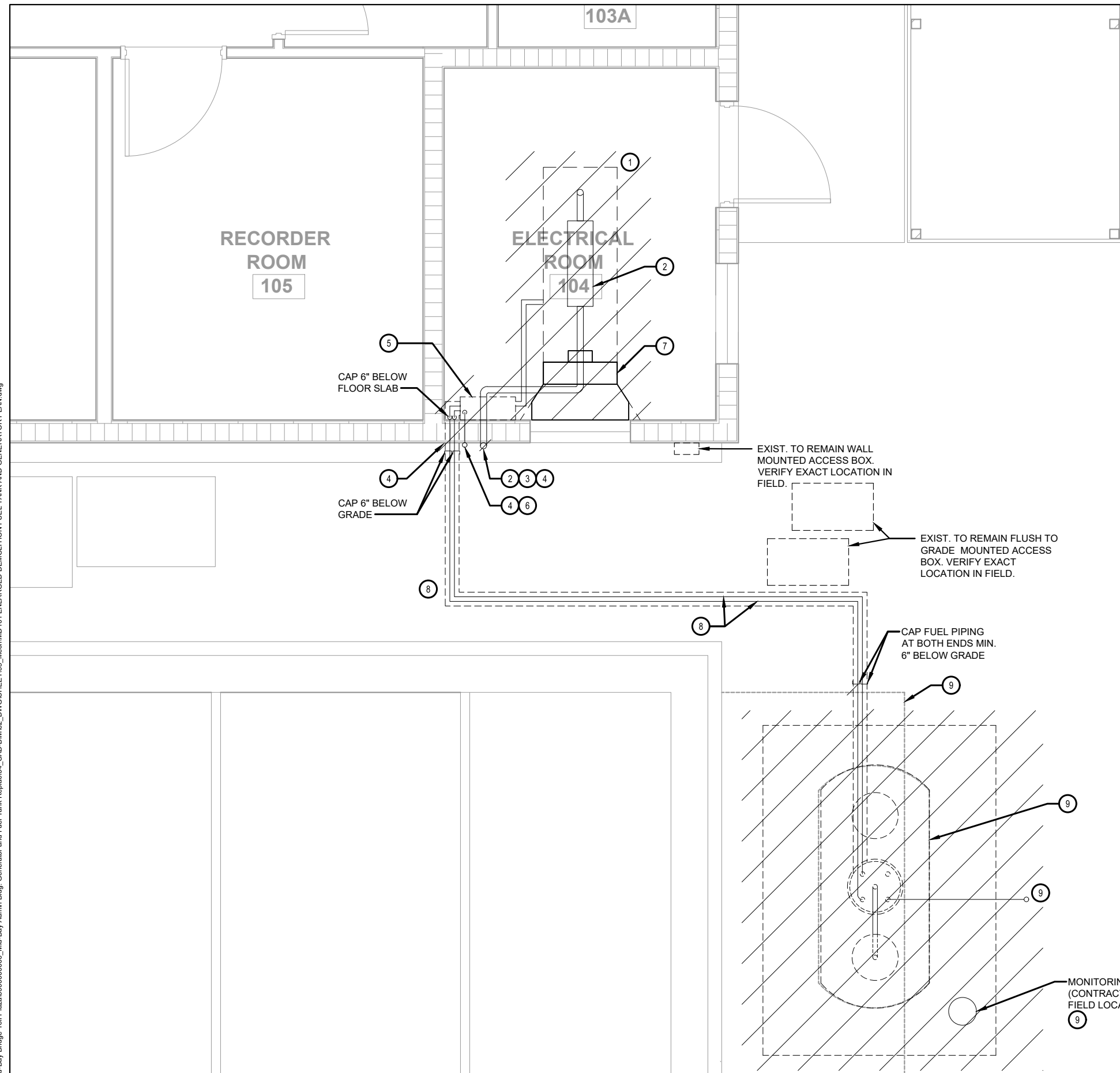

**DEMOLITION NOTES**

- ① EXISTING GENERATOR TO BE REMOVED.
- ② EXISTING GENERATOR EXHAUST SYSTEM INCLUDING MUFFLER, PIPING, HANGERS AND ACCESSORIES TO BE REMOVED.
- ③ EXISTING EXHAUST THIMBLE TO BE REMOVED.
- ④ PATCH WALL BOTH SIDES TO MATCH EXISTING IN BOTH MATERIAL AND FINISH.
- ⑤ EXISTING 50 GAL. DAY TANK, PIPING AND ACCESSORIES TO BE REMOVED.
- ⑥ EXISTING DAY TANK VENT PIPING AND ACCESSORIES TO BE REMOVED.
- ⑦ EXISTING EF-3 TO REMOVED AND REINSTALLED IN SAME LOCATION DUE TO REMOVAL OF EXISTING GENERATOR AND INSTALLATION ON NEW GENERATOR.
- ⑧ EXISTING FUEL PIPING SHALL BE ABANDONED IN PLACE. THE CONTRACTOR SHALL EVACUATE ALL EXISTING FUEL AND RESIDUE FROM TANKS, PIPING AND ACCESSORIES.
- ⑨ EXISTING 500 GAL. UNDERGROUND DIESEL FUEL TANK, PIPING, MANHOLES, MONITORING WELL, HOLD DOWN DEAD MAN, CONCRETE SLAB AND ACCESSORIES TO BE REMOVED AND AREA FILLED IN.

**NOTE:**

CONTRACTOR SHALL REMOVE AND CLEAN ALL EXISTING FUEL SYSTEM AND COMPONENTS. ALL FUEL SYSTEM EVACUATING AND ABANDONMENT SHALL BE PREFORMED IN ACCORDANCE WITH THE FLORIDA DEPARTMENT OF ENVIRONMENTAL PROTECTION AND ESCAMBIA COUNTY HEALTH DEPARTMENT.

**ENLARGED DEMOLITION FUEL TANK AND GENERATOR PLAN**

1  
MD101

SCALE: 1/4" = 1'-0"

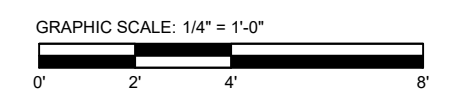

REVISIONS					
DATE	BY	DESCRIPTION	DATE	BY	DESCRIPTION

**ATKINS NORTH AMERICA, INC.**  
 800 Waterford Way, Suite 700  
 Miami, Florida 33126  
 305.592.7275  
 FBPR Certificate of Authorization No.: 24

<b>STATE OF FLORIDA DEPARTMENT OF TRANSPORTATION</b>		
ROAD NO.	COUNTY	FINANCIAL PROJECT ID
SR 293	OKALOOSA	413878-1-93-11

<b>MID-BAY BRIDGE TOLL PLAZA DESIGN CRITERIA GENERATOR AND FUEL TANK REPLACEMENT</b>
<b>ENLARGED DEMOLITION FUEL TANK AND GENERATOR PLAN</b>

DRAWING NO.	MD101
SHEET NO.	10

P:\TPK\20130000000000\_Mid-Bay Bridge Toll Plaza\000000000000\_Mid-Bay Admin Bldg\_Generator and Fuel Tank Replace\04\_CAD-BIM\02\_DWG\SHEET\05\_Mech\MD101 ENLARGED DEMOLITION FUEL TANK AND GENERATOR PLAN.dwg

**PROJECT : RENOVATION**  
**ISSUE DATE : AUGUST 2nd, 2019**

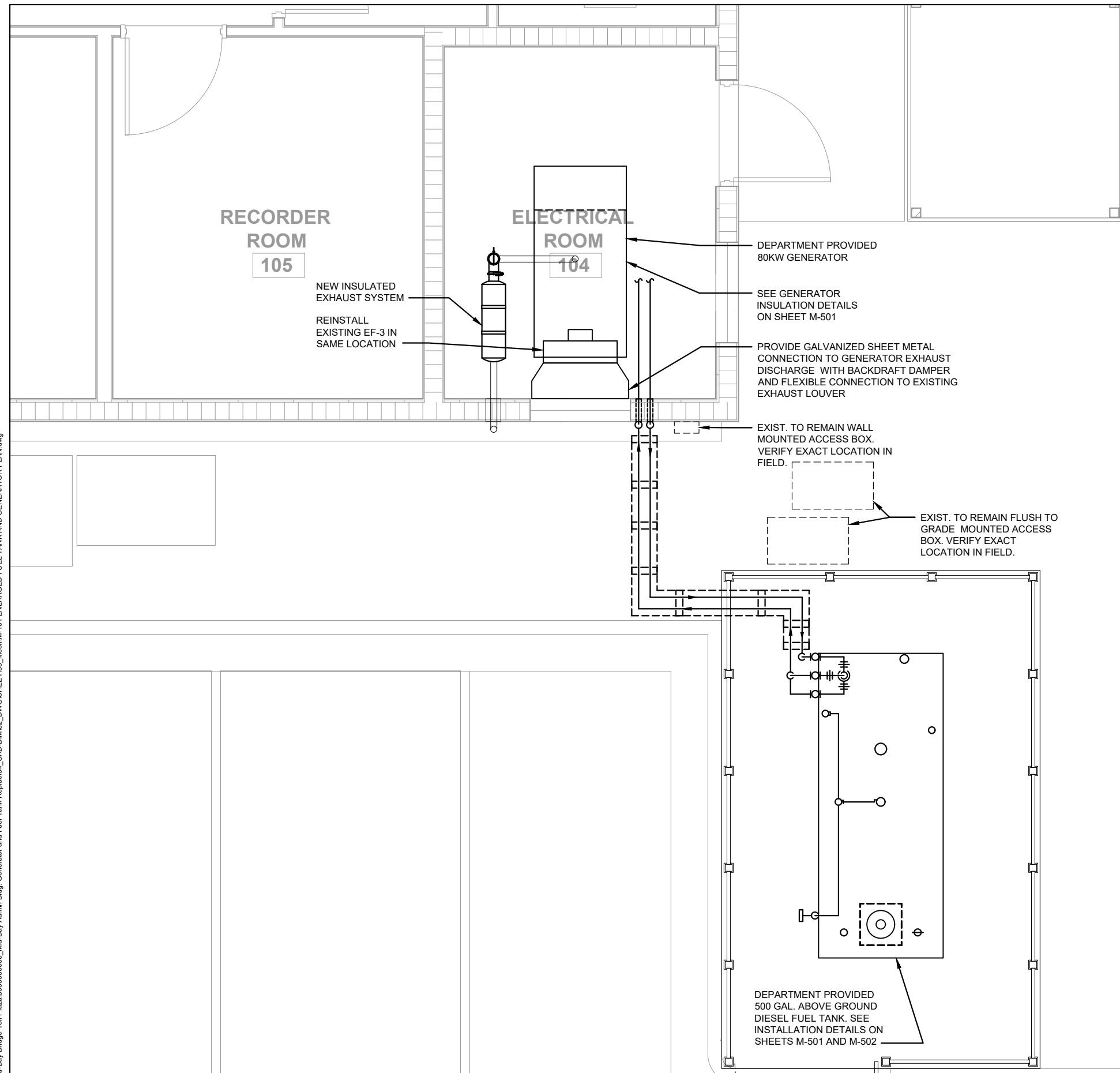

**NOTES:**

1. THE CONTRACTOR SHALL INSPECT THE TANK FOR CRACKS, CORROSION OR ANY DAMAGES PRIOR TO INSTALLATION TO THE NEW SITE. ANY ISSUES FOUND DURING THE INSPECTION SHALL BE REPORTED TO THE DEPARTMENT.
2. THE CONTRACTOR SHALL BE RESPONSIBLE TO FILL THE TANK WITH FUEL TO 95% FULL.

**ENLARGED FUEL TANK AND GENERATOR PLAN**

1  
M-101

SCALE: 1/4" = 1'-0"



GRAPHIC SCALE: 1/4" = 1'-0"



P:\TPK 2013\0000000000\_Mid-Bay Bridge Toll Plaza\0000000000\_Mid-Bay Admin Bldg\_Generator and Fuel Tank Replace\04\_CAD-BIM\02\_DWG\SHEET\05\_Mech\M-101 ENLARGED FUEL TANK AND GENERATOR PLAN.dwg

REVISIONS					
DATE	BY	DESCRIPTION	DATE	BY	DESCRIPTION

**ATKINS NORTH AMERICA, INC.**  
 800 Waterford Way, Suite 700  
 Miami, Florida 33126  
 305.592.7275  
 FBPR Certificate of Authorization No.: 24

<b>STATE OF FLORIDA DEPARTMENT OF TRANSPORTATION</b>		
ROAD NO.	COUNTY	FINANCIAL PROJECT ID
SR 293	OKALOOSA	413878-1-93-11

<b>MID-BAY BRIDGE TOLL PLAZA DESIGN CRITERIA GENERATOR AND FUEL TANK REPLACEMENT</b>
<b>ENLARGED FUEL TANK AND GENERATOR PLAN</b>

DRAWING NO. <b>M-101</b>
SHEET NO. <b>11</b>

**PROJECT : RENOVATION**  
**ISSUE DATE : AUGUST 2nd, 2019**

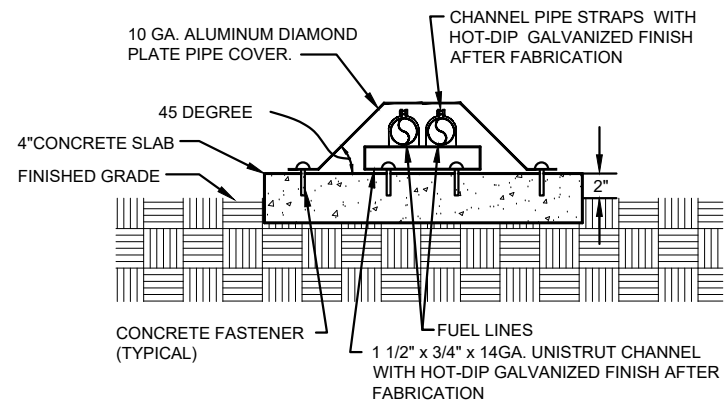

**NOTE:**

- FUEL PIPE COVER PLATE SHALL BE PROVIDED FOR ALL EXPOSED PIPING ROUTED WITHIN SERVICE WALKWAYS OR PATHS.

**1 FUEL PIPE SUPPORT AND COVER PLATE DETAIL**

M-501 SCALE: N.T.S.

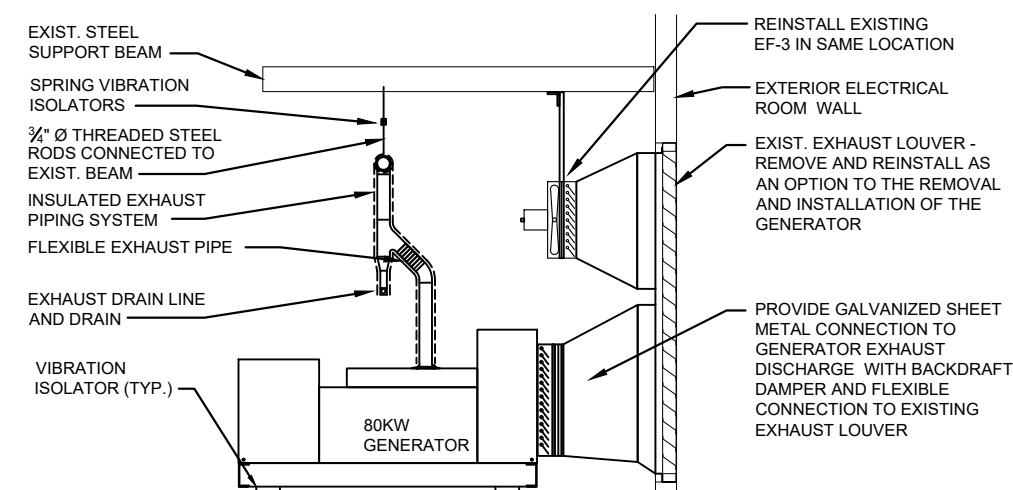

**2 GENERATOR SECTION INSTALLATION DETAIL**

M-501 SCALE: N.T.S.

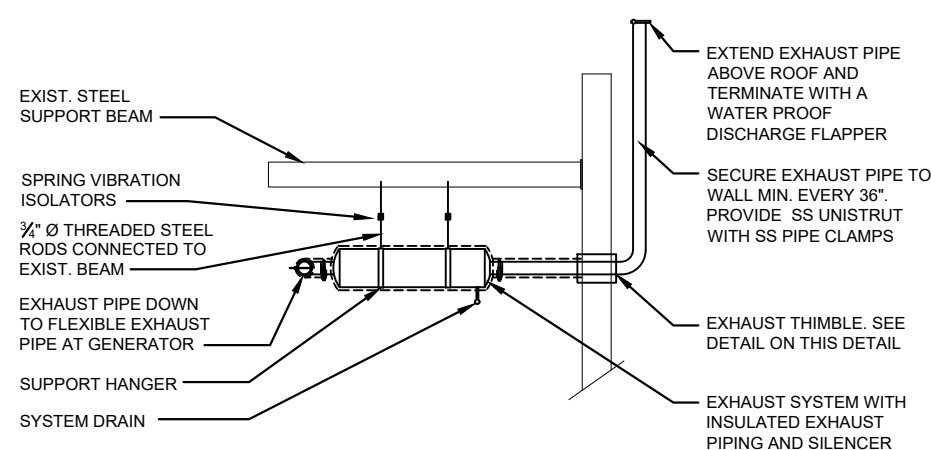

**3 SILENCER INSTALLATION DETAIL**

M-501 SCALE: N.T.S.

- NOTES:
- EXHAUST PIPE SHALL NOT MAKE CONTACT WITH THIMBLE.
  - OD: TWICE THE DIAMETER OF EXHAUST PIPE BEING USED.
  - ID: 1" LARGER THAN OUTSIDE DIAMETER OF EXHAUST PIPE.

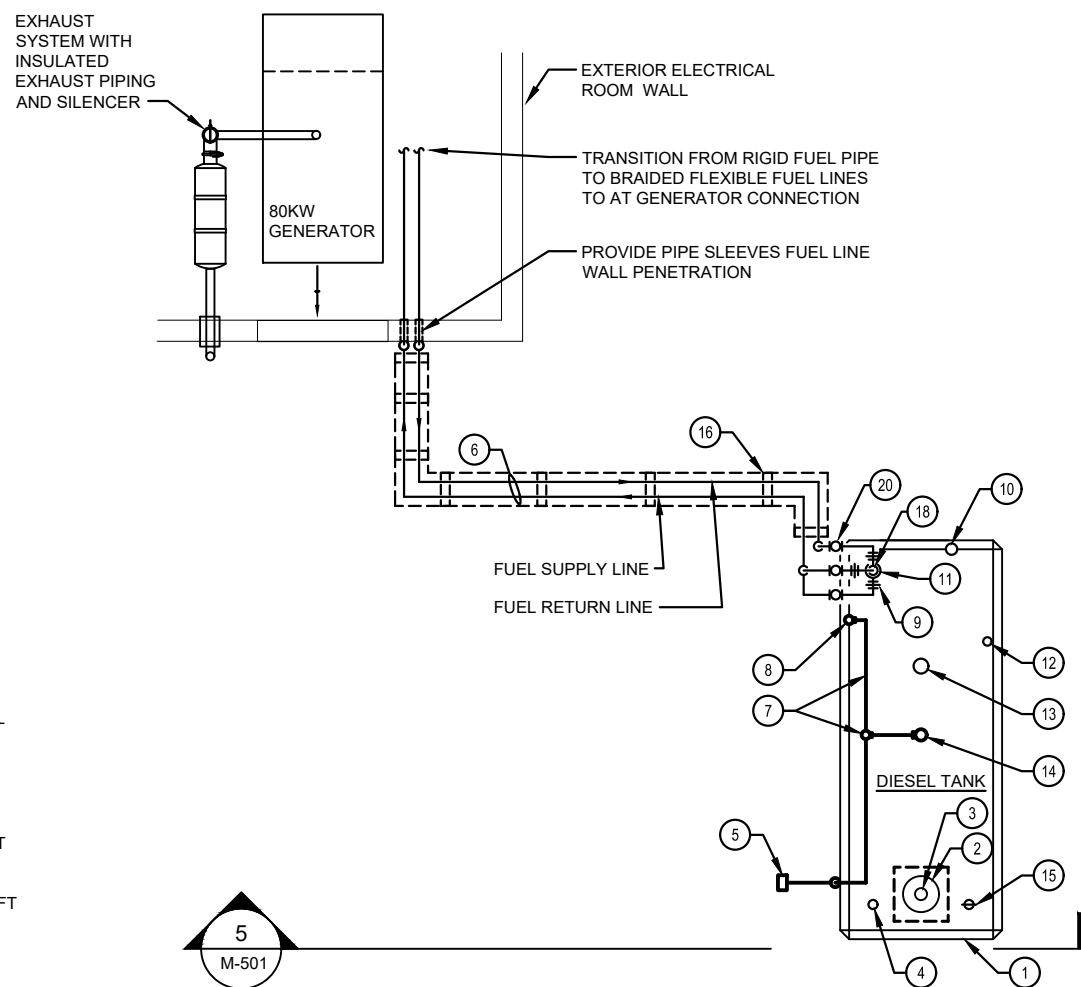
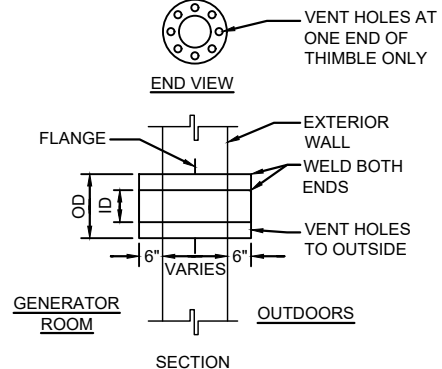

**4 FUEL FLOOR PLAN DETAIL**

M-501 SCALE: N.T.S.

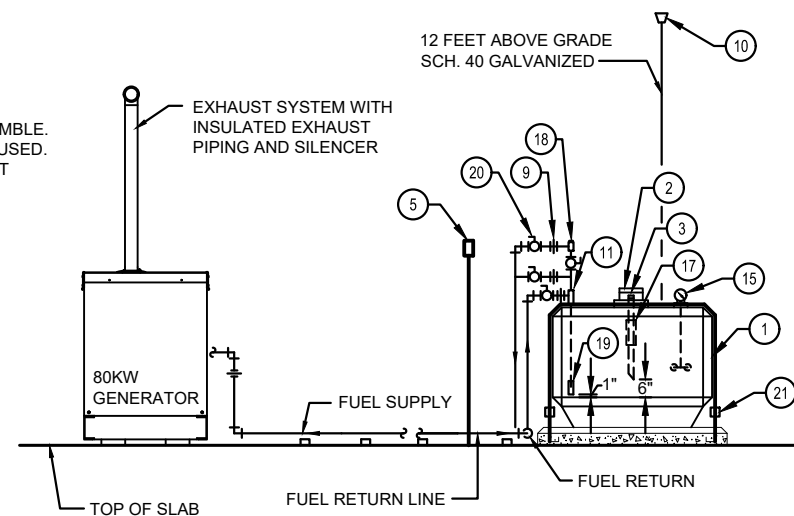

**5 ELEVATION DETAIL**

M-501 SCALE: N.T.S.

**GENERATOR FUEL TANK & ACCESSORIES**

- | ITEM No. | DESCRIPTION                                                                                                                                                                                                                                                                                                                                                 |
|----------|-------------------------------------------------------------------------------------------------------------------------------------------------------------------------------------------------------------------------------------------------------------------------------------------------------------------------------------------------------------|
| 1        | PROVIDED BY DEPARTMENT, INSTALLED BY CONTRACTOR. RECTANGULAR 500 GALLON ABOVE GROUND FIRE RATED MONOLITHIC CONCRETE VAULTED DIESEL FUEL TANK. TANK UL-142 AND UL-2085 LISTED. FDEP APPROVED EQUIPMENT LIST NO. EQ-750.                                                                                                                                      |
| 2        | 7 GALLON CAPACITY, (UL) LISTED OVERSPILL CONTAINMENT.                                                                                                                                                                                                                                                                                                       |
| 3        | 2" TANK INLET SPOUT ADAPTOR WITH DUST CAP.                                                                                                                                                                                                                                                                                                                  |
| 4        | 2" TANK INLET FOR FUEL LEVEL SENSOR. REFER TO ELECTRICAL DRAWINGS FOR DETAILS AND SPECIFICATION.                                                                                                                                                                                                                                                            |
| 5        | FUEL TANK MONITOR. SEE ELECTRICAL ENLARGED SITE PLANS FOR INSTALLATION LOCATION AND DETAILS. SEE SCADA SYSTEM BLOCK DIAGRAM AND NOTES FOR SPECIFIED FUEL TANK MONITOR AND CONNECTION ACCESSORIES.                                                                                                                                                           |
| 6        | 3/4" SCH. 40, BLACK IRON FUEL SUPPLY AND RETURN LINES.                                                                                                                                                                                                                                                                                                      |
| 7        | SEE ELECTRICAL DRAWINGS FOR CONDUIT, WIRING JUNCTION BOXES AND EQUIPMENT GROUNDING.                                                                                                                                                                                                                                                                         |
| 8        | LEAK DETECTION SWITCH AND STEM WITH SENSOR CABLE FOR TANK INTERSTITIAL SPACE MONITORING. PROVIDE WITH ALARM CONSOLE.                                                                                                                                                                                                                                        |
| 9        | 3/4" UNION.                                                                                                                                                                                                                                                                                                                                                 |
| 10       | 2" PRIMARY VENT AND CAP.                                                                                                                                                                                                                                                                                                                                    |
| 11       | 2" TANK FITTING FOR COMBINATION FUEL SUPPLY AND RETURN LINE.                                                                                                                                                                                                                                                                                                |
| 12       | 2" TANK FITTING AND OPEN VENT FITTING FOR TANK INTERSTITIAL SPACE.                                                                                                                                                                                                                                                                                          |
| 13       | 4" EMERGENCY VENT.                                                                                                                                                                                                                                                                                                                                          |
| 14       | 2" OPENING FOR HIGH/LOW LEVEL ALARM SWITCH. SET HIGH LEVEL AT 90% TANK FILL LEVEL AND LOW LEVEL AT 30% TANK FILL.                                                                                                                                                                                                                                           |
| 15       | LIQUID LEVEL CLOCK GAUGE WITH STAINLESS STEEL BALL AND CHAIN.                                                                                                                                                                                                                                                                                               |
| 16       | PIPE SUPPORT AND COVER PLATE. (SEE DETAIL)                                                                                                                                                                                                                                                                                                                  |
| 17       | AST OVERFILL PREVENTION VALVE ASSEMBLY, SET TO SHUT-OFF FUEL SUPPLY AT 95% TANK FILL.                                                                                                                                                                                                                                                                       |
| 18       | 3/4" UL LISTED ANTI-SIPHON VALVE DESIGNED FOR DIESEL FUEL APPLICATIONS WITH A FIELD ADJUSTABLE HYDROSTATIC HEAD PRESSURE OF 0'-12'. THE ANTI-SIPHON VALVE SHALL BE INSTALLED IN THE FUEL SUPPLY LINE FROM THE TANK WITH MANUAL BALL VALVES FOR BYPASSING AND ISOLATING THE ANTI-SIPHON VALVE. THE CONTRACTOR SHALL ADJUST VALVE TO ACTUAL FIELD CONDITIONS. |
| 19       | SUCTION STRAINER, WITH TYPE 304 STAINLESS STEEL 20 MESH SCREEN.                                                                                                                                                                                                                                                                                             |
| 20       | BALL VALVE.                                                                                                                                                                                                                                                                                                                                                 |
| 21       | TIE DOWN STRAP, TWO REQUIRED. REFER TO FUEL TANK ANCHORING DETAILS.                                                                                                                                                                                                                                                                                         |

**GENERAL NOTES:**

- CONTRACTOR SHALL COORDINATE FINAL LOCATION OF GENERATOR AND DIESEL FUEL TANK IN FIELD. PROVIDE LAYOUT AND CONFIGURATION TO THE DEPARTMENT FOR APPROVAL PRIOR TO INSTALLATION.
- FUEL LEVEL SENSOR, FUEL TANK MONITOR, AND ALL WIRED OR POWERED ACCESSORIES ARE PROVIDED AND INSTALLED BY THE ELECTRICAL CONTRACTOR UNLESS NOTED OTHERWISE. SEE MECHANICAL AND ELECTRICAL SPECIFICATIONS.
- MECHANICAL CONTRACTOR SHALL COORDINATE ALL TANK OPENINGS (SIZE AND LOCATION) WITH ELECTRICAL CONTRACTOR PRIOR TO ORDERING AND INSTALLING EQUIPMENT/COMPONENTS.

P:\TPK\2013\0000000000\_Mid-Bay Bridge Toll Plaza\0000000000\_Mid-Bay Admin Bldg. Generator and Fuel Tank Replace\04\_CAD-BIM\02\_DWG\01-SHEET\05\_MechM-501 GENERATOR DETAILS AND NOTES.dwg

REVISIONS					
DATE	BY	DESCRIPTION	DATE	BY	DESCRIPTION

**ATKINS NORTH AMERICA, INC.**  
 800 Waterford Way, Suite 700  
 Miami, Florida 33126  
 305.592.7275  
 FBPR Certificate of Authorization No.: 24

STATE OF FLORIDA DEPARTMENT OF TRANSPORTATION		
ROAD NO.	COUNTY	FINANCIAL PROJECT ID
SR 293	OKALOOSA	413878-1-93-11

MID-BAY BRIDGE TOLL PLAZA DESIGN CRITERIA GENERATOR AND FUEL TANK REPLACEMENT		DRAWING NO.
GENERATOR DETAILS AND NOTES		M-501
		SHEET NO.
		12

PROJECT : RENOVATION  
 ISSUE DATE : AUGUST 2nd, 2019

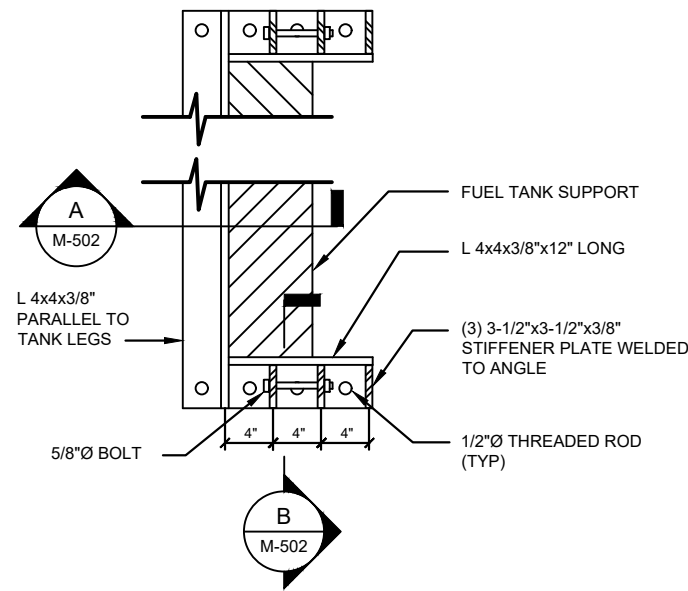

**1 PLAN VIEW**  
 M-502 SCALE: N.T.S.

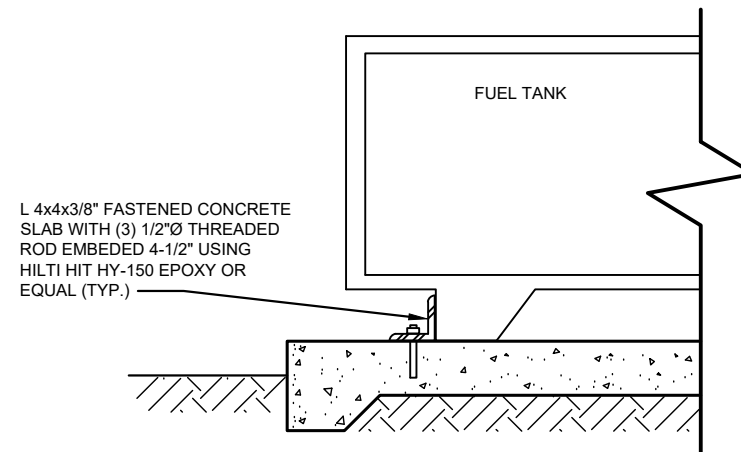

**A SECTION**  
 M-502 SCALE: N.T.S.

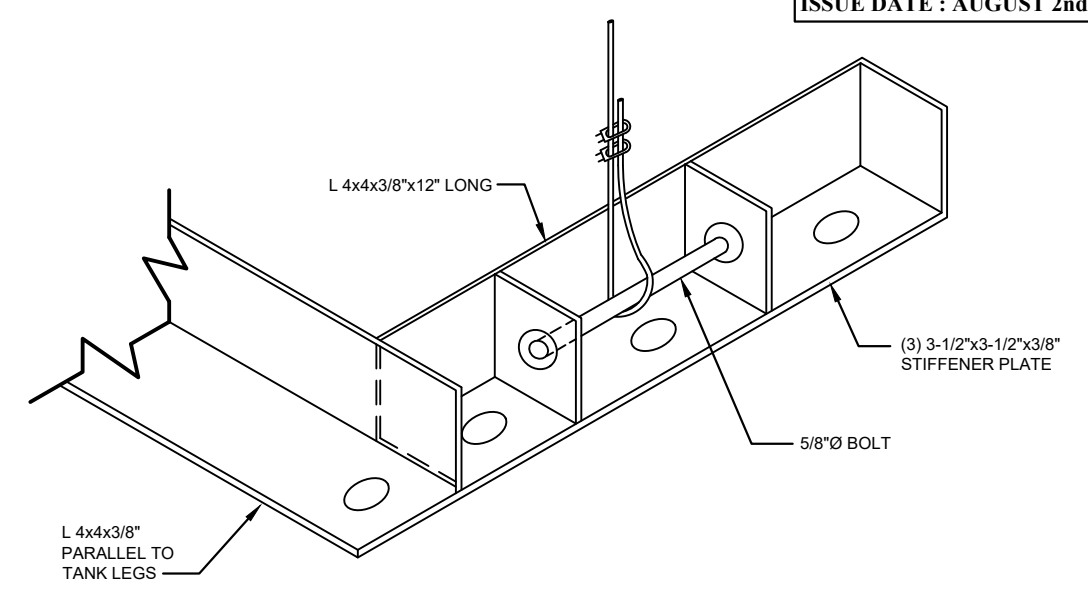

**2 FUEL TANK HOLD DOWN CABLES, ENLARGED VIEW**  
 M-502 SCALE: N.T.S.

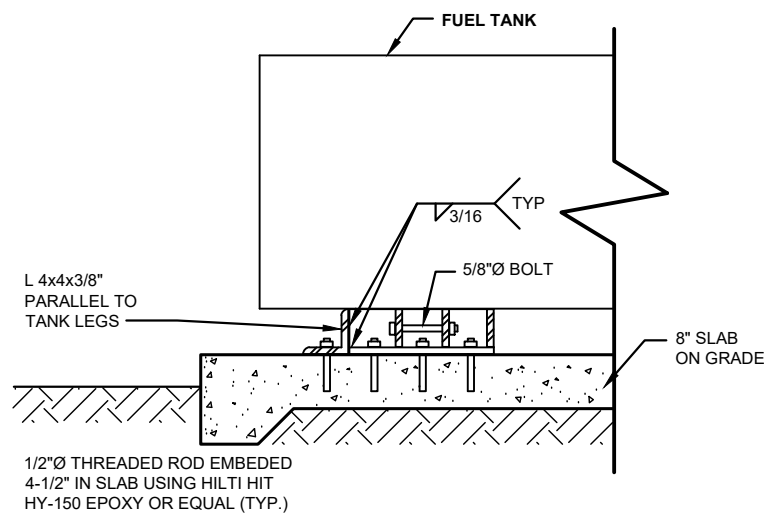

**3 ELEVATION**  
 M-502 SCALE: N.T.S.

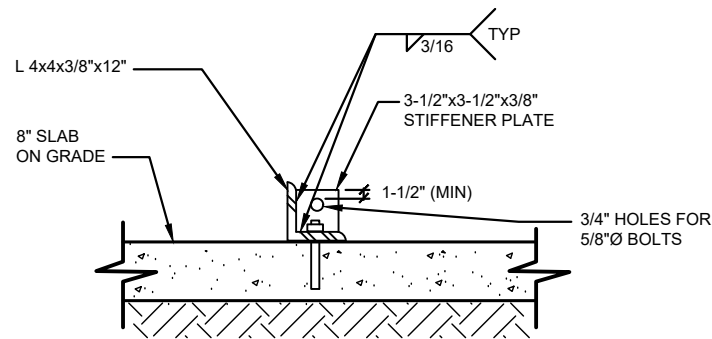

**B SECTION**  
 M-502 SCALE: N.T.S.

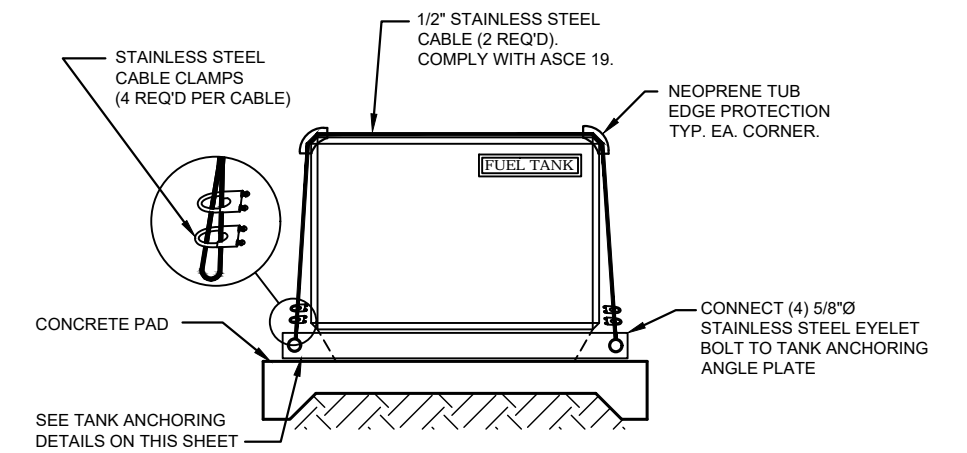

**4 FUEL TANK HOLD DOWN CABLES**  
 M-502 SCALE: N.T.S.

**NOTES:**

1. STRUCTURAL STEEL SHALL CONFORM TO ASTM A36.
2. ALL WELDS SHALL BE IN ACCORDANCE WITH AWS CODE. ELECTRODE SHALL BE E70XX.
3. THREADED ROD SHALL BE STANDARD ASTM A36.
4. BOLTS SHALL CONFORM TO ASTM A325.
5. PAINT ALL EXPOSED STEEL WITH GRAY COLD GALVANIZED PAINT.

DEPARTMENT PROVIDED TANK:  
 PROVIDE NEW OSHA AND ANSI COMPLIANT PERMANENT SAFETY SIGNS TO INDICATE THE FOLLOWING:

1. TYPE GRADE AND CLASS OF LIQUID IN TANK
2. HAZARD/DANGER
3. COMBUSTIBLE LIQUID
4. VOLUME OF TANK
5. NO SMOKING
6. NO OPEN FLAME

IDENTIFICATION SHALL BE POSITIONED SO THAT IT CAN BE EASILY SEEN FROM THE NORMAL ANGLE OF APPROACH.

P:\TPK\2013\0000000000\_Mid-Bay Bridge Toll Plaza\0000000000\_Mid-Bay Admin Bldg\_Generator and Fuel Tank Replace\04\_CAD-BIM\02\_DWG\SHEET\05\_MechM-502 FUEL TANK ANCHORING DETAILS.dwg

REVISIONS					
DATE	BY	DESCRIPTION	DATE	BY	DESCRIPTION

**ATKINS NORTH AMERICA, INC.**  
 800 Waterford Way, Suite 700  
 Miami, Florida 33126  
 305.592.7275  
 FBPR Certificate of Authorization No.: 24

STATE OF FLORIDA DEPARTMENT OF TRANSPORTATION		
ROAD NO.	COUNTY	FINANCIAL PROJECT ID
SR 293	OKALOOSA	413878-1-93-11

MID-BAY BRIDGE TOLL PLAZA DESIGN CRITERIA GENERATOR AND FUEL TANK REPLACEMENT	
<b>FUEL TANK ANCHORING DETAILS</b>	

DRAWING NO. <b>M-502</b>
SHEET NO. <b>13</b>

**PROJECT : RENOVATION**  
**ISSUE DATE : AUGUST 2nd, 2019**

**ELECTRICAL SYMBOL LEGEND**

SYMBOL	DESCRIPTION
	20 AMP. DUPLEX RECEPTACLE, MOUNTED 18" A.F.F. U.O.N.
	OUTLET OR JUNCTION BOX
	PANEL
	SELF ENCLOSED CIRCUIT BREAKER
	HOMERUN TO PANEL (E - PANEL DESIGNATION, 27 - CIRCUIT NUMBER)
AFF	ABOVE FINISH FLOOR
AHU	AIR HANDLER UNIT
AIC	AMPERE INTERRUPTING CAPACITY
A.,AMP.	AMPERE
ATS	AUTOMATIC TRANSFER SWITCH
C.,COND.	CONDUIT
CKT.	CIRCUIT
COUNT.	COUNTER
EF	EXHAUST FAN
ELEC.	ELECTRICAL
EX.,EXIST.	EXISTING
EQ.,EQUIP.	EQUIPMENT
F/N	FULL NEUTRAL
GEN.	GENERATOR
GFI	GROUND FAULT INTERRUPTER
GND.,G.	GROUND
HP	HEAT PUMP
KVA	KILO VOLT AMPERE
KW	KILOWATT
LTG	LIGHTING
LTS	LIGHTS
MCB	MAIN CIRCUIT BREAKER
MLO	MAIN LUGS ONLY
N.T.S.	NOT TO SCALE
Ø, PH	PHASE
P	POLE
RECEPT., REC.	RECEPTACLE
STOR.	STORAGE
TEL.	TELEPHONE
TYP.	TYPICAL
U.O.N.	UNLESS OTHERWISE NOTED
V	VOLT
VAV	VARIABLE AIR VOLUME
W	WIRE
WR	WEATHER PROOF
WR	WATER RESISTANCE

**ELECTRICAL GENERAL NOTES:**

- PRIOR TO BID, VISIT JOB SITE AND BECOME FAMILIAR WITH THE EXISTING CONDITIONS. SPECIAL ATTENTION SHALL BE GIVEN TO CONDITIONS OF PANELS AND SWITCHING EQUIPMENT WHERE NEW WORK IS REQUIRED. MODIFY EXISTING PANELS AND EQUIPMENT BY THE ADDITION OF CIRCUIT BREAKERS, WIRING, ETC. AS REQUIRED IN ORDER TO PROVIDE A COMPLETE AND OPERATING SYSTEM. NO EXTRA COMPENSATION WILL BE ALLOWED FOR FAILURE TO COMPLY WITH THIS REQUIREMENT.
- ALL WORK SHALL BE DONE IN ACCORDANCE WITH THE NATIONAL ELECTRICAL CODE (N.E.C.), AND GOVERNING MUNICIPAL, STATE AND LOCAL CODES, AND SHALL BE PERFORMED IN A THOROUGH AND WORKMAN LIKE MANNER BY COMPETENT WORKMEN.
- CONTRACTOR SHALL GUARANTEE THE ENTIRE ELECTRICAL WORK, INCLUDING PARTS AND LABOR FOR A PERIOD OF ONE (1) YEAR AFTER FINAL WRITTEN ACCEPTANCE OF OWNER.
- ALL WORK SHALL BE PERFORMED BY A LICENSED ELECTRICAL CONTRACTOR IN A FIRST CLASS MANNER AND SHALL BE COMPLETED AND FULLY OPERATIVE TO THE ACCEPTANCE OF OWNER.
- MAINTAIN A COMPLETE SET OF ELECTRICAL PRINTS FOR INDICATING ALL CHANGES. USE COLORED PENCILS TO MARK CHANGES AT THE TIME OF EXECUTION AND DELIVER THE SET TO ARCHITECT / ENGINEER UPON COMPLETION.
- ALL MATERIALS SHALL BE NEW, OF AMERICAN MANUFACTURE, AND BEAR THE UNDERWRITER'S LABORATORY AND UNION LABELS AS APPLICABLE. IT IS THE CONTRACTOR'S RESPONSIBILITY TO COORDINATE DELIVERY SCHEDULES OF MATERIALS.
- CIRCUIT BREAKERS SHALL BE MOLDED CASE, BOLT-ON TYPE, OF QUICK-MAKE ACTION, RATED AT 10,000 (120V), 65,000 (277/480V) AIC RMS. SYMMETRICAL. EACH MOLDED CASE CIRCUIT BREAKER SHALL HAVE THERMAL MAGNETIC TRIP DEVICE.
- LIGHTING FIXTURES SHALL BE COMPLETE WITH ALL NECESSARY WIRING LAMP HOLDERS, REFLECTORS, GLASSWARE AND MOUNTING ACCESSORIES AS REQUIRED AND POLES.
- CONTRACTOR SHALL MAKE ALL NECESSARY EXCAVATIONS, CUTTING AND DO ALL REATTACHING AS NECESSARY FOR THE PROPER EXECUTION OF THIS WORK.
- AFTER COMPLETION OF THE INSTALLATION, THE SYSTEM SHALL TEST FREE FROM SHORT CIRCUITS AND GROUNDS.
- ALL ELECTRICAL CONDUCTORS SHALL BE INSTALLED IN CONDUIT. CONDUITS SHALL COMPLY WITH N.E.C. PVC CONDUIT SHALL BE SCHEDULE 40 AND SHALL BE USED WHERE CONDUIT IS RUN IN CONCRETE SLABS, OR UNDERGROUND. ELECTRICAL METALLIC TUBING CONDUIT SHALL BE USED ON ALL INTERIOR WIRING. GRS CONDUIT SHALL BE USED ON ALL EXTERIOR WIRING.
- ALL CONDUCTORS SHALL BE COPPER. NO CONDUCTOR SHALL BE SMALLER THAN No. 12 AWG. INSTALL A GROUNDING CONDUCTOR IN ALL PVC CONDUITS SIZED PER N.E.C. INSULATION SHALL BE 600V. RATED AND SHALL BE THWN.
- VERIFY SERVICE VOLTAGE BEFORE ORDERING ANY ELECTRICAL EQUIPMENT.
- SPLICES FOR No. 6 AWG OR SMALLER SHALL BE MADE WITH UL LISTED MECHANICAL PRESSURE CONNECTORS. SPLICES FOR No. 4 AWG OR LARGER SHALL BE MADE WITH MECHANICAL PRESSURE, SOLDERLESS CONNECTORS, AND SHALL BE BURNDY SERVITS OR APPROVED EQUAL.
- ANY EXISTING EQUIPMENT OR DEVICES INADVERTENTLY DE-ENERGIZED OR DISCONNECTED SHALL BE RE-ENERGIZED AT NOT COST TO THE OWNER.
- EXISTING EQUIPMENT REMOVED SHALL BECOME THE PROPERTY OF THE OWNER AND SHALL BE REMOVED FROM THE JOB SITE.
- COVER PLATES USED ON ALL WIRING DEVICES SHALL MATCH EXISTING.
- OUTLET BOXES SHALL BE GALVANIZED, WITH SUITABLE PLASTER RINGS OR TRIMS TO CONFORM TO FINISH SURFACE AS REQUIRED. EXTRA LARGE BOXES SHALL BE USED IN ACCORDANCE WITH N.E.C. IN PLACE OF SIZE INDICATED WHERE NECESSARY TO PREVENT UNDUE CROWDING OF WIRES. GANG BOXES SHALL BE USED FOR GANG SWITCHES.
- SAFETY SWITCHES SHALL BE HEAVY DUTY, FUSED OR NON-FUSED AND SIZES AS INDICATED.
- GROUNDING SHALL BE IN ACCORDANCE WITH ARTICLE 250 OF THE N.E.C.
- LOADS IN GUTTERS SHALL BE PROPERLY BALANCED BETWEEN PHASES.
- EQUIPMENT SUPPLY BY OTHERS TO BE CONNECTED BY ELECTRICAL CONTRACTOR.
- ELECTRICAL CONTRACTOR TO COORDINATE HIS WORK WITH ALL OTHER TRADES.
- ANY DISCREPANCIES ARE TO BE BROUGHT TO THE ATTENTION OF THE ARCHITECT AND ENGINEER BEFORE PROCEEDING WITH THE WORK.
- PRIOR TO INSTALLATION OF ROUGH ELECTRICAL WIRING, CHECK NAMEPLATE DATA ON A/C EQUIPMENT TO OBTAIN CORRECT WIRE SIZES AND OVERCURRENT PROTECTION.
- REFER TO MECHANICAL DRAWINGS FOR EXACT LOCATION OF MECHANICAL EQUIPMENT.
- ELECTRICAL DESIGN COMPLIES WITH THE FLORIDA ENERGY CODE - ENERGY CONSERVATION, 5TH EDITION.
- CIRCUIT BREAKERS SERVING HVAC EQUIPMENT WITH A REQUIREMENT FOR HACR BREAKERS, IN THE RANGE OF 15 - 60 AMPS, UL APPROVED HACR BREAKERS SHALL BE USED.
- ALL CONTACTORS TO BE ELECTRICALLY OR MECHANICALLY HELD AS INDICATED ON THE DRAWINGS.
- NEW WIRING DEVICES TO MATCH TYPE AND COLOR OF THE EXISTING DEVICES.
- PROVIDE PULLWIRE IN EMPTY RACEWAYS.
- PROVIDE NEW TYPED DIRECTORIES FOR PANELBOARDS.
- MINIMUM CONDUIT SIZE FOR ELECTRICAL WORK SHALL BE 3/4" AND FOR DAT/VOICE SHALL BE 1" CONDUIT.
- PROVIDE SIGNAGE "WARNING OF ARC FLASH HAZARD" AND LABELS FOR ARC FLASH AS PER NEC 110.16

**WIRE SIZE REQUIRED FOR BRANCH CIRCUITS AT LESS THAN 3% VOLTAGE DROP**

		1 FT	51 FT	76 FT	101 FT	126 FT	151 FT
		TO 50 FT	TO 75 FT	TO 100 FT	TO 125 FT	TO 150 FT	TO 200 FT
120 V	20A	#12	#10	#8	#8	#6	#6
	30A	#10	#8	#6	#6	#6	#4
	40A	#8	#6	#6	#4	#4	#3
	50A	#8	#6	#4	#4	#3	#2
208 V 1Ø	20A	#12	#12	#12	#10	#10	#8
	30A	#10	#10	#10	#8	#8	#6
	40A	#8	#8	#8	#8	#6	#6
	50A	#8	#8	#8	#6	#6	#4
	60A	#6	#6	#6	#6	#4	#4
	70A	#4	#4	#4	#4	#4	#3
	80A	#4	#4	#4	#4	#4	#3
	90A	#3	#3	#3	#3	#3	#2
208 V 3Ø	20A	#12	#12	#12	#10	#10	#8
	30A	#10	#10	#10	#8	#8	#6
	40A	#8	#8	#8	#8	#6	#6
	50A	#8	#8	#8	#6	#6	#4
	60A	#6	#6	#6	#6	#6	#4
	70A	#4	#4	#4	#4	#4	#4
	80A	#4	#4	#4	#4	#4	#3
	90A	#3	#3	#3	#3	#3	#3
100A	#3	#3	#3	#3	#3	#2	

CALCULATED USING COPPER WIRE AT 75 C.

BRANCH CIRCUITS HAVE BEEN CALCULATED FOR SINGLE PHASE VOLTAGE DROP BASED ON SINGLE PHASE CIRCUIT

P:\TPK 2013\0000000000\_Mid-Bay Bridge Toll Plaza\0000000000\_Mid-Bay Admin Bldg\_Generator and Fuel Tank Replace\04\_CAD-BIM\02\_DWG\SHEET\08\_Elec\E-001 ELECTRICAL SYMBOL LEGEND, GENERAL NOTES AND WIRE SCHEDULE.dwg

REVISIONS						<b>ATKINS NORTH AMERICA, INC.</b> 800 Waterford Way, Suite 700 Miami, Florida 33126 305.592.7275 FBPR Certificate of Authorization No.: 24	STATE OF FLORIDA DEPARTMENT OF TRANSPORTATION			MID-BAY BRIDGE TOLL PLAZA DESIGN CRITERIA GENERATOR AND FUEL TANK REPLACEMENT		DRAWING NO.
DATE	BY	DESCRIPTION	DATE	BY	DESCRIPTION		ROAD NO.	COUNTY	FINANCIAL PROJECT ID	<b>ELECTRICAL SYMBOL LEGEND, GENERAL NOTES                  AND WIRE SCHEDULE</b>		SHEET NO.
							SR 293	OKALOOSA	413878-1-93-11			14



**PROJECT : RENOVATION**  
**ISSUE DATE : AUGUST 2nd, 2019**

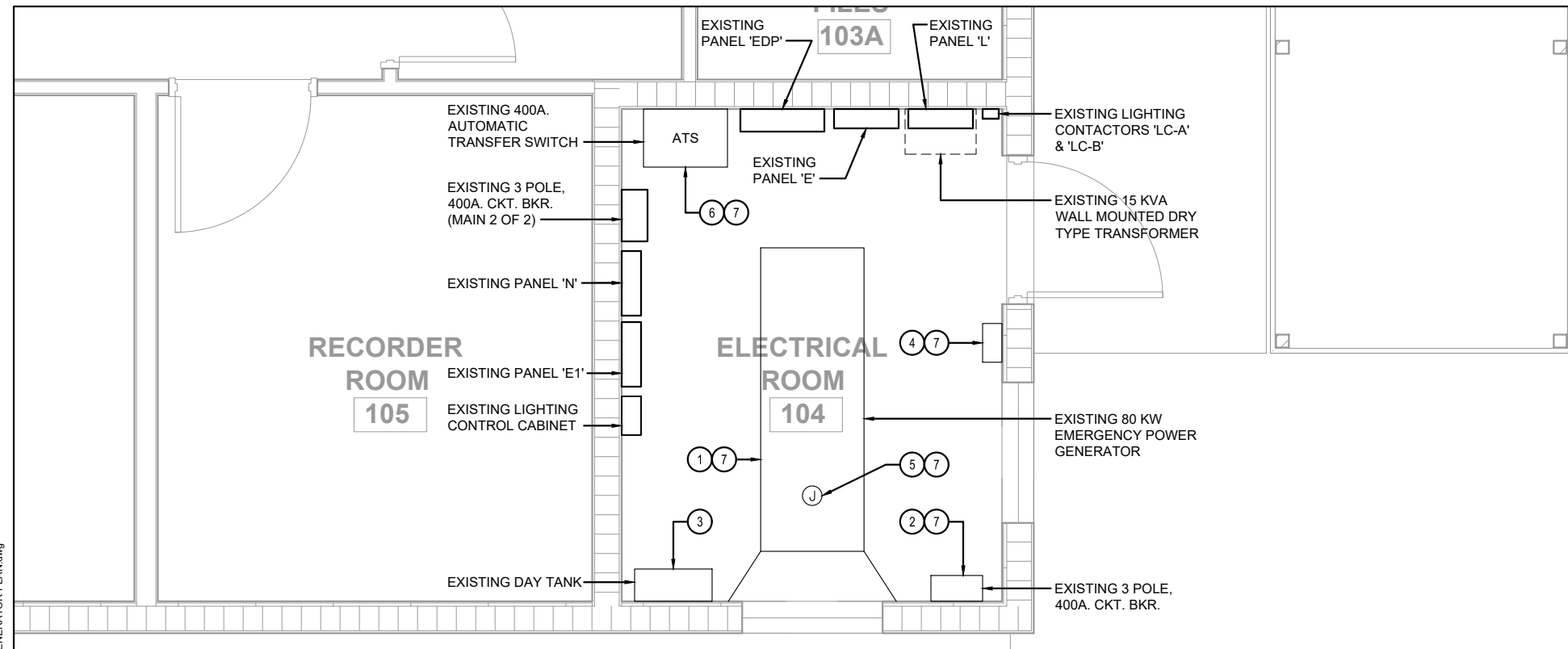

**DEMOLITION NOTES**

- ① DISCONNECT AND REMOVE EXISTING 80KW, 120/208V, 3Ø, 4W GEN SET.
- ② DISCONNECT AND REMOVE EXISTING 3P. 400 C.B.
- ③ DISCONNECT AND REMOVE EXISTING DAY TANK.
- ④ DISCONNECT AND REMOVE EXISTING BATTERY CHARGER CONNECTION. EXISTING CIRCUIT TO BE RE-USED.
- ⑤ DISCONNECT AND REMOVE EXISTING JACKET WATER HEATER CONNECTION. EXISTING CIRCUIT TO BE RE-USED.
- ⑥ DISCONNECT AND REMOVE EXISTING 400 AMP. ATS.
- ⑦ DISCONNECT AND REMOVE WIRING BACK TO THE LAST REMAINING DEVICE.

P:\TPK\2013\0000000000\_Mid-Bay Bridge Toll Plaza\0000000000\_Mid-Bay Admin Bldg\_Generator and Fuel Tank Replace\04\_CAD-BIM\02\_DWG\SHEET\08\_Elect\ED101 ENLARGED DEMOLITION FUEL TANK AND GENERATOR PLAN.dwg

EXISTING 500 GAL. UNDERGROUND DIESEL FUEL TANK TO BE REMOVED SEE MECHANICAL DRAWINGS

**ENLARGED DEMOLITION FUEL TANK AND GENERATOR PLAN**  
 1 ED101 SCALE: 1/4" = 1'-0"

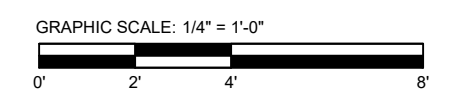

REVISIONS					
DATE	BY	DESCRIPTION	DATE	BY	DESCRIPTION

**ATKINS NORTH AMERICA, INC.**  
 800 Waterford Way, Suite 700  
 Miami, Florida 33126  
 305.592.7275  
 FBPR Certificate of Authorization No.: 24

STATE OF FLORIDA DEPARTMENT OF TRANSPORTATION		
ROAD NO.	COUNTY	FINANCIAL PROJECT ID
SR 293	OKALOOSA	413878-1-93-11

MID-BAY BRIDGE TOLL PLAZA DESIGN CRITERIA GENERATOR AND FUEL TANK REPLACEMENT
<b>ENLARGED DEMOLITION FUEL TANK AND GENERATOR PLAN</b>

DRAWING NO. ED101
SHEET NO. 16



**PROJECT : RENOVATION**  
**ISSUE DATE : AUGUST 2nd, 2019**

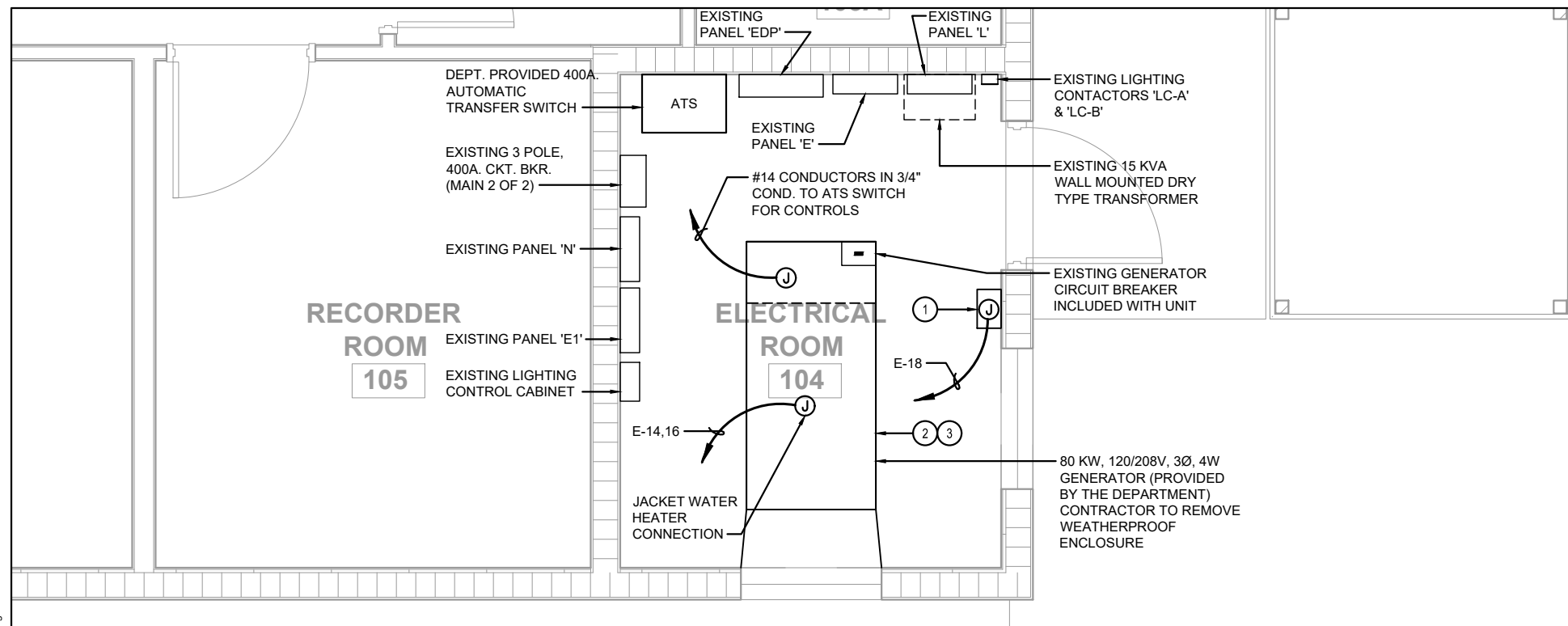

- NOTE:**
- ① PROVIDE AND INSTALL NEW BATTERY CHARGER.
  - ② THE CONTRACTOR SHALL BE RESPONSIBLE TO REMOVE AND DISPOSE THE GENERATOR UNIT EXTERIOR HOUSING (METAL ENCLOSURE).
  - ③ THE CONTRACTOR SHALL BE RESPONSIBLE TO INSPECT, TEST AND CLEAN THE DEPARTMENT PROVIDED GENERATOR PRIOR TO INSTALLATION TO THE NEW SITE. ANY ISSUES FOUND DURING THE INSPECTION AND TESTING SHALL BE REPORTED TO THE DEPARTMENT.

P:\TPK\2013\0000000000\_Mid-Bay Bridge Toll Plaza\0000000000\_Mid-Bay Admin Bldg\_Generator and Fuel Tank Replace\04\_CAD-BIM\02\_DWG\SHEET\08\_Elec\E-101 ENLARGED FUEL TANK AND GENERATOR PLAN.dwg

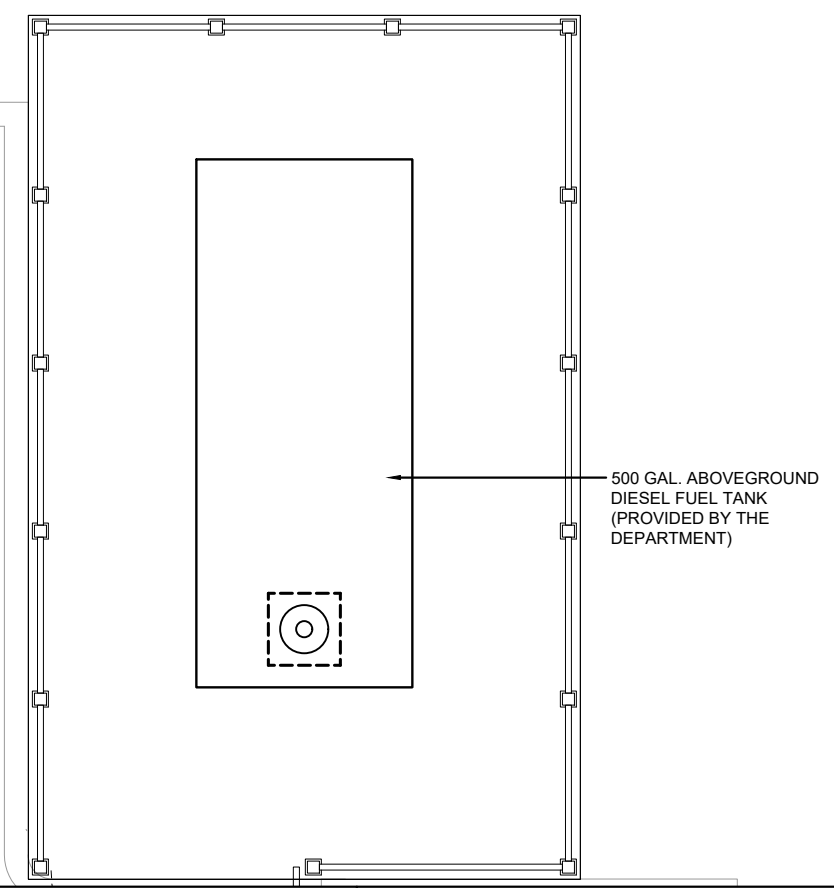

**ENLARGED FUEL TANK AND GENERATOR PLAN**

① E-101 SCALE: 1/4" = 1'-0"

GRAPHIC SCALE: 1/4" = 1'-0"

0' 2' 4' 8'

REVISIONS					
DATE	BY	DESCRIPTION	DATE	BY	DESCRIPTION

**ATKINS NORTH AMERICA, INC.**  
 800 Waterford Way, Suite 700  
 Miami, Florida 33126  
 305.592.7275  
 FBPR Certificate of Authorization No.: 24

**STATE OF FLORIDA**  
**DEPARTMENT OF TRANSPORTATION**

ROAD NO.	COUNTY	FINANCIAL PROJECT ID
SR 293	OKALOOSA	413878-1-93-11

**MID-BAY BRIDGE TOLL PLAZA DESIGN CRITERIA**  
**GENERATOR AND FUEL TANK REPLACEMENT**

**ENLARGED FUEL TANK AND GENERATOR PLAN**

DRAWING NO.  
E-101

SHEET NO.  
17



**ATTACHMENT "B"**  
**CERTIFICATION**  
**DISBURSEMENT OF PREVIOUS PAYMENTS**

Date: \_\_\_\_\_, 20\_\_\_\_\_

Contract No.: \_\_\_\_\_

Financial Project No(s): \_\_\_\_\_

**Contract For:**

To release payment for all work performed in the Month of, \_\_\_\_\_, 20\_\_\_\_\_

\_\_\_\_\_  
(State)

\_\_\_\_\_  
(Zip)

As prime contractor for the above referenced Contract, hereby certifies that all subcontractors, laborers, and material suppliers having an interest in this Contract have received their pro rata share of all previous payments made by the Department for all work completed and materials and equipment furnished in the previous period.

\_\_\_\_\_  
(Name of Business)

\_\_\_\_\_  
(Signature) Owner, President, Vice President or Designated Officer (Corp. Resolution\*)

\_\_\_\_\_  
(Address)

\_\_\_\_\_  
(Print/Type Name)

\_\_\_\_\_  
(City)

\_\_\_\_\_  
(Title)

\*If person signing for the Business is someone other than the Owner, President, or Vice President, a copy of the Corporate Resolution granting signature authorization must be attached to form.

**CERTIFICATION MUST BE ATTACHED TO INVOICE**

**ATTACHMENT "C"**

STATE OF FLORIDA DEPARTMENT OF TRANSPORTATION  
CERTIFICATE OF CONTRACT COMPLETION

Contract Number \_\_\_\_\_ FPI No.: \_\_\_\_\_

Project Description \_\_\_\_\_

Contractor \_\_\_\_\_

Contract Date \_\_\_\_\_ Total Amount \$ \_\_\_\_\_

**CONTRACTOR'S AFFIDAVIT**

I solemnly swear and affirm: That the work under the above named Contract and all Amendments and Supplements thereto have been completed in accordance with the requirements of said Contract; that all costs incurred for equipment, materials, labor, and services against the project have been paid; that no liens have been attached against the project; that no suits are pending by reason of work on the project under the Contract; that all Worker's Compensation claims are covered by Worker's Compensation insurance as required by law; that all public liability claims are adequately covered by insurance, and that the Owner shall save, protect, defend, indemnify, and hold the Department harmless from and against any and all claims which arise as a direct or indirect result of any transaction, event or occurrence related to performance of the work contemplated under said contract.

\_\_\_\_\_  
(Signature), Owner, President, Vice President or other Designated Officer (Corp. Resolution\*) \_\_\_\_\_ (Title)

**(Corporate Seal)**

STATE OF \_\_\_\_\_

COUNTY OF \_\_\_\_\_

The foregoing affidavit was acknowledged before me this \_\_\_\_\_ day of \_\_\_\_\_, 20\_\_\_\_\_

by \_\_\_\_\_, on behalf of the Vendor. He/She is personally known to me or has  
(Print/Type Name of Person Signing Above)

produced \_\_\_\_\_, as identification.  
(Type of Identification)

Notary Public: \_\_\_\_\_  
(Signature)

**(Notary Stamp)**

Type/Print Name: \_\_\_\_\_

\* If person signing for the Business is someone other than the Owner, President, or Vice President, a copy of the Corporate Resolution granting signature authorization must be furnished in the bid package.

**CERTIFICATION MUST BE ATTACHED TO THE FINAL INVOICE**

**FLORIDA DEPARTMENT  
OF TRANSPORTATION**



**EXHIBIT “B”**  
**METHOD OF COMPENSATION**

**DOT-ITB-20-8025-AC**

**GENERATOR, FUEL TANK AND AUTOMATIC TRANSFER SWITCH (ATS) REPLACEMENT  
AT MID-BAY BRIDGE ADMINISTRATION BUILDING, SR 293, MILEPOST 5.0**

**FPID: 413878-1-93-11**

**EXHIBIT "B"**  
**METHOD OF COMPENSATION**

**GENERATOR, FUEL TANK AND AUTOMATIC TRANSFER SWITCH (ATS) REPLACEMENT  
AT MID-BAY BRIDGE ADMINISTRATION BUILDING, SR 293, MILEPOST 5.0**

**1.0 General**

The Vendor shall accept the compensation as provided in this Contract as full payment for furnishing all labor, materials and equipment, for performing all work under this Contract, and for all other costs including, but not limited to: tolls, dump fees, fuel and any documentation required in this Contract. All work not specifically defined shall be included in the bid item(s).

**2.0 Pay Item Definition (Basis of Payment)**

The Department agrees to pay the Vendor for the services performed, an amount of compensation and method of payment as described and detailed herein and in Exhibit "C," Bid Blank.

**2.1 GENERATOR, FUEL TANK AND AUTOMATIC TRANSFER SWITCH (ATS)  
REPLACEMENT:**

The pay item below represents the total and full compensation to the Vendor for furnishing all labor, materials, tools, equipment including pickup, handling & delivery of Vendor supplied equipment, supplies, travel time and expenses, transportation, mobilization, disposal, safety and worker protection, profit, overhead, markups, supervisor and all other incidental expenses and costs incurred by the Vendor necessary to perform generator, fuel tank and ATS replacement as specified in this Contract and Attachment "A," Design Criteria for a turn-key project. No payment will be made for stockpile material. The removal and disposal of existing equipment shall be done in accordance with all applicable local, state, and federal requirements, laws, and regulations.

**PAY ITEM NO. 1 – GENERATOR, FUEL TANK AND AUTOMATIC TRANSFER  
SWITCH (ATS) REPLACEMENT, LUMP SUM (LS).**

**3.0 Method of Measurement**

All measurement of payment will be based on the actual amount of work completed and accepted, in strict accordance with the specifications and all codes/standards specified herein and approved by the Department's Project/Contract Manager. Work completed under this Contract shall be measured according to the methods outlined in the basis of payment hereunder and shall be paid for at the Contract unit price for such activity.

**3.1 Compensation**

The Vendor shall be paid, per the compensation details in this Exhibit and price schedule in the Exhibit "C," Bid Blank for the work accomplished and accepted by the Department's Project/Contract Manager. The total payment made to the Vendor shall not exceed the maximum amount of the face value of the Contract, without Supplemental Agreement being processed.

**3.2 Method of Payment**

Partial payments shall be allowed for this project. The Department reserves the right to withhold full payment or partial payment of the Vendor's invoice when less than the work performed listed on the invoice or work performed were inadequate, not authorized, or not completed.

**3.3 Invoicing**

Payment will be made to the Vendor following receipt and approval of an invoice package for all work performed and accepted by the Department's Project/Contract Manager.

The Vendor's invoice package shall be submitted to the address below.

Department of Transportation  
PO Box 9828  
Fort Lauderdale, FL 33310  
Attn: To be determined

- A. The invoice package shall be a legible summary on the Vendor's letterhead that includes the following:
1. Company Name
  2. Address
  3. Remittance address if different from mailing address
  4. Date of Service
  5. Contract or Purchase Order Number
  6. Pay Item Number & Description
  7. Quantity
  8. Unit Price
  9. Total Amount of Invoice
  10. Total Labor Hours
- B. The "LABOR HOURS" are the total number of expended hours times the number of employees assigned to perform the work. The information is required for entry into the Department's Maintenance Management System (MMS) only, and not intended as a basis of payment.
- 3.4 The Vendor shall provide a statement (Attachment "B," Certification Disbursement of Previous Payments), with all but the first and last pay request to the Department which certifies that the Vendor has disbursed to all sub-vendors, laborers, and materials suppliers, having an interest in the Contract, their pro-rata shares of the payment, out of the previous payments received by the Vendor for all work completed and materials furnished in the previous period. This certification shall be in the form designated by the Department. The Department shall not make any payments after the initial payment until the Vendor furnishes said certification, unless the Vendor demonstrates good cause for not making any such required payment and provides written notification of any such good cause to both, the Department and the affected sub-vendors, laborers, and material suppliers.
- 3.5 The Vendor shall submit a Certificate of Contract Completion with the final invoice (see Attachment "C").
- 3.6 In the event that funds paid to the Vendor under this Contract are subsequently disallowed by the Department because of accounting errors or charges not in conformity with this Contract, the Vendor agrees that such disallowed amounts are due to the Department upon demand. Further, Vendor agrees that the Department shall have the right to deduct from any payment due to the Vendor under any other Contract between the Vendor and the Department or under this Contract, an amount sufficient to satisfy any amount due and owing the Department by the Vendor.

**FLORIDA DEPARTMENT  
OF TRANSPORTATION**



**EXHIBIT "C"**  
**BID BLANK**

**DOT-ITB-20-8025-AC**

**GENERATOR, FUEL TANK AND AUTOMATIC TRANSFER SWITCH (ATS) REPLACEMENT  
AT MID-BAY BRIDGE ADMINISTRATION BUILDING, SR 293, MILEPOST 5.0**

**FPID: 413878-1-93-11**



**EXHIBIT “C”  
 BID BLANK**

**GENERATOR, FUEL TANK AND AUTOMATIC TRANSFER SWITCH (ATS)  
 REPLACEMENT AT MID-BAY BRIDGE ADMINISTRATION BUILDING, SR 293,  
 MILEPOST 5.0**

PAY ITEM NO.	DESCRIPTION	UNIT	QUANTITY OF ITEM	PAY ITEM TOTAL
1	GENERATOR, FUEL TANK AND AUTOMATIC TRANSFER SWITCH (ATS) REPLACEMENT AS SPECIFIED IN THIS CONTRACT	Lump Sum (LS)	1	\$ _____.

The undersigned has completed and is returning the following documents as part of its bid package and understands that failure to return any of these documents fully completed may cause rejection of the bid.

*The following forms must be completed and submitted by or prior to the bid due date and time, in order for the bid to be responsive:*

\_\_\_ Bid Blank: Exhibit C, Page C-1 thru C-2.

\_\_\_ A copy of the Vendor’s Business Tax Receipt, stating the name of the Bidder’s business, the street address of the business where all the work covered under the Contract will be handled, and the type of work that covers the services being called for in the Contract.

\_\_\_ A copy of the Vendor’s license(s) as a certified or registered Vendor, authorized to perform the work specified in this bid package in the State of Florida in accordance with the laws of the State of Florida. (Refer to Exhibit “A,” Scope of Services; Section 3.0, Vendor’s Qualifications)

\_\_\_ A current letter from a surety company or bonding agent authorized to do business in the State of Florida. (Refer to Exhibit “A,” Scope of Services; Section 3.0, Vendor’s Qualifications)

\_\_\_ All forms supplied with the bid package (Forms 1 thru 4) return Form 5 & 6 if applicable. Be certain to fill in all the blanks on the forms supplied; do not leave any blank lines on the forms. Sign and return each form. (If awarded the Contract, Form 7 will be required)

\_\_\_ Submit documentation of the work experience with the bid package.

**MFMP Transaction Fee:** All payment(s) to the Vendor resulting from this competitive solicitation WILL be subject to the MFMP Transaction Fee in accordance with the referenced Form PUR 1000 General Contract Condition #14. The Transaction Fee imposed shall be based upon the date of issuance of the payment.

Name of Business: \_\_\_\_\_

**Fill in the following information, complete with authorized signature and date.**

Name of Business: (Print) \_\_\_\_\_

Business Address: \_\_\_\_\_

City: \_\_\_\_\_ State: \_\_\_\_\_ Zip Code: \_\_\_\_\_

Federal I.D. No. : \_\_\_\_\_ M.B.E.: Yes No

Phone Number: ( ) \_\_\_\_\_ Email Address: \_\_\_\_\_

**Emergency Contact Information (After Hours):**

Name: \_\_\_\_\_ Phone Number: ( ) \_\_\_\_\_

Email Address: \_\_\_\_\_ Fax No. :( ) \_\_\_\_\_

Cellular Number: ( ) \_\_\_\_\_

Authorized Signature: \_\_\_\_\_

Title: \_\_\_\_\_  
Owner, President, or Designated Officer (Corporate Resolution)\*\*

Print Name: \_\_\_\_\_ Date: \_\_\_\_\_

Phone Number: ( ) \_\_\_\_\_ Email Address: \_\_\_\_\_

\*\*If person signing the form is someone other than the Owner, President, or Vice President, a copy of the Corporate Resolution granting signature authorization must be furnished in the bid package.