

**State of Florida
Department of Transportation**



INVITATION TO BID
Asphalt Binder Auto Extraction Device

DOT-ITB-20-9088-SJ

RESPONSES DUE:

Tuesday, March 3, 2020 @ 3:00PM EST

CONTACT FOR QUESTIONS:

Sherill Johnson, Procurement Agent
605 Suwannee Street, Mail Station 20
Tallahassee, Florida 32399-0450
sherill.johnson@dot.state.fl.us
Phone: (850) 414-4381

BID SHEET

BID #: DOT-ITB-20-9088-SJ

FOB: Florida Department of Transportation
State Materials Office
5007 NE 39th Avenue
Gainesville, Florida 32609

BID TITLE: Asphalt Binder Auto Extraction Device

BID AS SPECIFIED OR APPROVED EQUIVALENT

Asphalt Binder Auto Extraction Device
(As outlined within Exhibit A – Technical Specifications) \$ _____

DELIVERY: Delivery will be made within _____ days after receipt of Purchase Order.

Is this product available with recycled content? __Yes __No

If yes, please send information separate from this Invitation to Bid (See Recycled Material Special Condition for more information).

MFMP Transaction Fee:

All payment(s) to the vendor resulting from this competitive solicitation **WILL** be subject to the MFMP Transaction Fee in accordance with the referenced Form PUR 1000 General Contract Condition #14. The Transaction Fees imposed shall be based upon the date of issuance of the payment.

NOTE: In submitting a response, the bidder acknowledges they have read and agree to the solicitation terms and conditions and their submission is made in conformance with those terms and conditions.

ACKNOWLEDGEMENT: I certify that I have read and agree to abide by all terms and conditions of this solicitation and that I am authorized to sign for the bidder. I certify that the response submitted is made in conformance with all requirements of the solicitation.

Bidder: _____ FEID# _____

Address: _____ City, State, Zip: _____

Phone: _____ Fax: _____ E-mail: _____

Authorized Signature: _____ Date: _____

Printed/Typed: _____ Title: _____

STATE OF FLORIDA DEPARTMENT OF TRANSPORTATION
DRUG-FREE WORKPLACE PROGRAM CERTIFICATION

375-040-18
PROCUREMENT
03/17

287.087 Preference to businesses with drug-free workplace programs. --Whenever two or more bids, proposals, or replies that are equal with respect to price, quality, and service are received by the state or by any political subdivision for the procurement of commodities or contractual services, a bid, proposal, or reply received from a business that certifies that it has implemented a drug-free workplace program shall be given preference in the award process. In order to have a drug-free workplace program, a business shall:

(1) Publish a statement notifying employees that the unlawful manufacture, distribution, dispensing, possession, or use of a controlled substance is prohibited in the workplace and specifying the actions that will be taken against employees for violations of such prohibition.

(2) Inform employees about the dangers of drug abuse in the workplace, the business's policy of maintaining a drug-free workplace, any available drug counseling, rehabilitation, and employee assistance programs, and the penalties that may be imposed upon employees for drug abuse violations.

(3) Give each employee engaged in providing the commodities or contractual services that are under bid a copy of the statement specified in subsection (1).

(4) In the statement specified in subsection (1), notify the employees that, as a condition of working on the commodities or contractual services that are under bid, the employee will abide by the terms of the statement and will notify the employer of any conviction of, or plea of guilty or nolo contendere to, any violation of Chapter 893 or of any controlled substance law of the United States or any state, for a violation occurring in the workplace no later than 5 days after such conviction.

(5) Impose a sanction on, or require the satisfactory participation in a drug abuse assistance or rehabilitation program if such is available in the employee's community by, any employee who is so convicted.

(6) Make a good faith effort to continue to maintain a drug-free workplace through implementation of this section.

Does the individual responding to this solicitation certify that their firm has implemented a drug-free workplace program in accordance with the provision of Section 287.087, Florida Statutes, as stated above?

YES

NO

NAME OF BUSINESS: _____

STATE OF FLORIDA DEPARTMENT OF TRANSPORTATION
IN-STATE PREFERENCE FORM
For Invitation-to-Bid Commodity

375-040-56
PROCUREMENT
OGC – 08/18

Bid Number: _____

Title: _____

Pursuant to Section 287.084, Florida Statutes, relating to the Florida-based business preference, effective July 1, 2012:

In a competitive solicitation in which the lowest bid is submitted by a vendor whose principal place of business is located outside the state of Florida and that state where the vendor's principal place of business is located does not grant a preference in competitive solicitation to vendors having a principal place of business in that state, the preference to the lowest responsible and responsive vendor having a principal place of business in this state shall be 5 percent.

Note: The Vendor is *MUST* complete and submit this form with its bid. Failure to submit will result in the vendor being found non-responsive.

Vendor Name: _____

Vendor FEIN: _____

The Vendor (does) (does not) have a principal place of business located in the state of Florida.

If so, please provide an address:

Note: Pursuant to Section 287.084(2) A vendor whose principal place of business is outside the state of Florida **must accompany any written bid** documents with a written opinion of an attorney licensed to practice law in that foreign state, as to the preferences, if any or none, granted by the law of that state to its own business entities whose principal places of business is in that foreign state in the letting of any or all public contracts. **Failure to submit the written opinion will result in the vendor being found non-responsive.**

Authorized Signature: _____

Title: _____

Date: _____

STATE OF FLORIDA DEPARTMENT OF TRANSPORTATION
**VENDOR CERTIFICATION REGARDING
SCRUTINIZED COMPANIES LISTS**

Respondent Vendor Name: _____
Vendor FEIN: _____
Vendor's Authorized Representative Name and Title: _____
Address: _____
City: _____ State: _____ Zip: _____
Phone Number: _____
Email Address: _____

Section 287.135, F.S. prohibits a company from bidding on, submitting a proposal for, or entering into or renewing a contract for goods or services of any amount if the company is on the Scrutinized Companies that Boycott Israel List, created pursuant to Section 215.475, F.S. or is engaged in a boycott of Israel. Section 287.135, F.S. also prohibits a company from bidding on, submitting a proposal for, or entering into or renewing a contract for goods or services of \$1,000,000 or more, if the company is on either the Scrutinized Companies with Activities in Sudan List, or the Scrutinized Companies with Activities in the Iran Petroleum Energy Sector Lists which are created pursuant to s. 215.473, F.S.

As the person authorized to sign on behalf of Respondent, I hereby certify that the company identified above in the section entitled "Respondent Vendor Name" is not listed on either the Scrutinized Companies with Activities in Sudan List or the Scrutinized Companies with Activities in the Iran Petroleum Energy Sector List, or the Scrutinized Companies that Boycott Israel List. I further certify that the company is not engaged in a boycott of Israel. I understand that pursuant to section 287.135, Florida Statutes, the submission of a false certification may subject company to civil penalties, attorney's fees, and/or costs.

Certified By: _____
who is authorized to sign on behalf of the above referenced company.
Authorized Signature Print Name and Title: _____
Date: _____

INTRODUCTION SECTION

1) INVITATION

The purpose of this Invitation to Bid is to obtain competitive bids for the purchase of Asphalt Binder Auto Extraction Device by the Department of Transportation, hereafter referred to as the "Department".

All commodities identified in this Invitation to Bid will be subject to the availability of identical commodities as provided by mandatory Department of Management Services' State Contract(s) at such time these commodities become available. In the event of duplication(s) of commodities, the Department of Management Services' mandatory State Contract shall prevail.

2) TIMELINE

Provided below is a list of critical dates and actions. These dates are subject to change. Notices of changes (Addenda) will be posted on the Florida Vendor Bid System at www.myflorida.com (click on "BUSINESS", click on "Doing Business with the State", under "Everything for Vendors and Customers", click on "Vendor Bid System (VBS)", click on "Search Advertisements") under this bid number. It is the responsibility of all potential bidders to monitor this site for any changing information prior to submitting your bid.

<u>ACTION / LOCATION</u>	<u>DATE</u>	<u>LOCAL TIME</u>
DEADLINE FOR TECHNICAL QUESTIONS (There is no deadline for administrative questions)	02-20-2020	05:00 PM
BIDS DUE (ON OR BEFORE) Florida Department of Transportation Central Procurement Office Attn: Sherill Johnson, Procurement Agent 605 Suwannee Street, Mail Station 20 Tallahassee, Florida 32399-0450 Phone: (850) 414.4381	03-03-2020	03:00 PM
PUBLIC OPENING Florida Department of Transportation Central Procurement Office Attn: Sherill Johnson, Procurement Agent 605 Suwannee Street, Room 129 Tallahassee, Florida 32399-0450	03-03-2020	03:00 PM
POSTING OF INTENDED DECISION/AWARD	03-09-2020	

3) BID OPENING AGENDA

The sealed bids will be opened by the Department's Procurement Office personnel at the date, time and location in the Timeline. All bid openings are open to the public and will be conducted according to the following agenda:

Opening remarks – Approximate time of 2 minutes by Department Procurement Office personnel.
Public input period – To allow a maximum of 15 minutes total for public input related to the bid solicitation.

Bids opened – At conclusion of public input or 15 minutes, whichever occurs first, bids received timely will be opened with bidder's name and prices to be read aloud.

Adjourn - After all bids received timely have been opened, the meeting will be adjourned.

4) **SPECIAL ACCOMMODATIONS**

Any person with a qualified disability requiring special accommodations at a pre-bid conference, public meeting, and/or opening shall contact the contact person at the phone number, e-mail address or fax number provided on the title page at least five (5) working days prior to the event. If you are hearing or speech impaired, please contact this office by using the Florida Relay Services which can be reached at 1 (800) 955-8771 (TDD).

SPECIAL CONDITIONS

1) **MyFloridaMarketPlace (MFMP)**

BIDDERS MUST BE ACTIVELY REGISTERED IN THE STATE OF FLORIDA'S MYFLORIDAMARKETPLACE SYSTEM BY THE TIME AND DATE OF THE BID OPENING OR THEY MAY BE CONSIDERED NON-RESPONSIVE (see Special Condition 21). All prospective bidders that are not registered, should go to <https://vendor.myfloridamarketplace.com/> to complete on-line registration, or call 1-866-352-3776 for assisted registration.

All payment(s) to the vendor resulting from this competitive solicitation **WILL** be subject to the 1% MFMP Transaction Fee in accordance with the referenced Form PUR 1000 General Contract Condition #14. The Transaction Fees imposed shall be based upon the date of issuance of the payment.

2) **Florida Department of Financial Services (DFS) W-9 REQUIREMENT**

The Florida Department of Financial Services (DFS) requires all vendors that do business with the state to submit an electronic Substitute Form W-9. Vendors must submit their W-9 forms electronically at <https://flvendor.myfloridacfo.com> to receive payments from the state. Contact the DFS Customer Service Desk at (850) 413-5519 or FLW9@myfloridacfo.com with any questions.

3) **QUESTIONS & ANSWERS**

In accordance with section 287.057(23), Florida Statutes, respondents to this solicitation or persons acting on their behalf may not contact, between the release of the solicitation and the end of the 72-hour period following the agency posting the notice of intended award, excluding Saturdays, Sundays, and state holidays, any employee or officer of the executive or legislative branch concerning any aspect of this solicitation, except in writing to the procurement officer or as provided in the solicitation documents. Violation of this provision may be grounds for rejecting a response.

Any technical questions arising from this Invitation to Bid must be forwarded, in writing, to the procurement agent identified below. Questions must be received no later than the time and date reflected on the Timeline. The Department's written response to written inquiries submitted timely by bidders will be posted on the Florida Vendor Bid System at www.myflorida.com (click on "BUSINESS", click on "Doing Business with the State", under "Everything for Vendors and Customers", click on "Vendor Bid System (VBS)", click on "Search Advertisements"), under this bid number. It is the responsibility of all potential bidders to monitor this site for any changing information prior to submitting their bid.

WRITTEN TECHNICAL QUESTIONS should be submitted to:

FDOT Procurement Office

Attn: Sherill Johnson

605 Suwannee, Street, Mail Station 20, Tallahassee, Florida 32399-0450

Or sherill.johnson@dot.state.fl.us

Questions regarding administrative aspects of the bid process should be directed to the Procurement Agent in writing at the address above or by phone: (850) 414-4381

4) **ORAL INSTRUCTIONS / CHANGES TO THE INVITATION TO BID (ADDENDA)**

No negotiations, decisions, or actions will be initiated or executed by a bidder as a result of any oral discussions with a State employee. Only those communications which are in writing from the Department will be considered as a duly authorized expression on behalf of the Department.

Notices of changes (Addenda) will be posted on the Florida Vendor Bid System at www.myflorida.com (click on "BUSINESS", click on "Doing Business with the State", under "Everything for Vendors and Customers", click on "Vendor Bid System (VBS)", click on "Search Advertisements") under this bid number. It is the responsibility of all potential bidders to monitor this site for any changing information prior to submitting your bid. All Addenda will be acknowledged by signature and subsequent submission of Addenda with bid when so stated in the Addenda.

5) **DIVERSITY ACHIEVEMENT**

The Department, in accordance with *Title VI of the Civil Rights Act of 1964, 42 USC 2000d-2000d-4, Title 49, Code of Federal Regulations, U.S. Department of Transportation, Subtitle A, Office of the Secretary, Part 21*, Nondiscrimination in federally-assisted programs of the Department of Transportation issued pursuant to such Act, hereby notifies all bidders that the Department will affirmatively ensure that in any contract/agreement entered into pursuant to this advertisement, minority and disadvantaged business enterprises will be afforded the full opportunity to submit bids in response to this invitation and will not be discriminated on the basis of race, color, national origin, or sex in consideration for an award.

The Department encourages the recruitment and utilization of small, minority, women, and service-disabled veteran businesses. The Department, its vendors, suppliers, and consultants should take all necessary and reasonable steps to ensure that small, minority, women, and service-disabled veteran businesses have the opportunity to compete for and perform contract work for the Department in a nondiscriminatory environment.

6) **PRICES/DELIVERY**

Prices shall be firm, net, delivered prices, F.O.B. destination.

7) **IN-STATE PREFERENCE FOR COMMODITY BIDS**

In accordance with Section 287.084, Florida Statutes, when the lowest responsible and responsive bid is submitted by a vendor whose principal place of business is located outside the state of Florida, a 5% price preference shall be awarded to the lowest responsible and responsive vendor whose principal place of business is located in the state of Florida, **as determined by the vendor's registration with the Florida Department of State (SunBiz)**, unless the state where the out-of-state vendor is located provides a price preference for businesses having a principal place of business in that state. In that case, the same price preference shall be awarded to the lowest responsible and responsive vendor whose principal place of business is located in the state of Florida responding to this Invitation to Bid (ITB).

All bidders MUST complete the attached "In-State Preference Form" and **submit with their bid response**. All vendors whose principal place of business is outside of Florida, as determined by the vendor's registration with the Florida Department of State (SunBiz), **must accompany any written bid, proposal, or reply documents** with a written opinion of an attorney at law licensed to practice law in that foreign state, as to the preferences, if any or none, granted by the law of that state to its own business entities whose principal places of business are in that foreign state in the letting of any or all public contracts. **Failure to submit the "In-State Preference Form AND written opinion will result in the vendor being found non-responsive.**

For the 5% preference, the Department will apply 5% to the bid price(s) of the lowest out of state vendor whose state does not grant a preference if that vendor has submitted the lowest responsible and responsive bid. The "In-State Preference" does not apply to transportation projects that use federal funds.

8) INTENDED AWARD

As the best interest of the State may require, the right is reserved to make award(s) by individual item, group of items, all or none, or a combination thereof: on a geographical district basis and / or on a statewide basis with one or more suppliers, to reject any and all bids or waive any minor irregularity or technicality in bids received. When it is determined there is competition to the lowest responsible bidder, evaluation of other bids is not required. Bidders are cautioned to make no assumptions, unless their bid has been evaluated as being responsive. All awards made as a result of this bid shall conform to applicable Florida Statute. If the Department is confronted with identical pricing or scoring from multiple vendors, the Department shall determine the order of award using the following criteria, in the order of preference listed below (from highest priority to lowest priority):

1. Section 295.187(4), Florida Statutes; Veteran Business Enterprise
2. Section 287.087, Florida Statute; Drug Free Work Place
3. Section 287.057(11); Minority Business Enterprise

In the event that the application of the above referenced preferences does not resolve the identical replies, the Department shall determine the award by means of random drawing.

9) PRE-BID CONFERENCE

A PRE-BID CONFERENCE WILL NOT BE HELD.

10) ALTERNATES

Alternate brands will be considered for this bid. The "Department" reserves the right to require each bidder to demonstrate to the satisfaction of the "Department" that the items/materials will perform in a completely acceptable manner. In the event the "Department" judges that the demonstrated performance is unsatisfactory, the "Department" may reject the bid. The bidder must be prepared to demonstrate the materials within fourteen (14) days after the bid opening date. Demonstration time and place is subject to agreement of the "Department" and the bidder.

Bidders submitting a bid that is based on an alternate brand of equipment must submit, with their bid, complete specifications and descriptive technical literature for the equipment proposed.

11) WARRANTY/SUBSTITUTIONS

A warranty is required on all equipment and components purchased against defective materials, workmanship, and failure to perform in accordance with required industry performance criteria, for a period of not less than twelve (12) months from the date of initial installation and operation at the State Materials Office by the Vendor and acceptance by the purchaser. Any deviation from these criteria must be documented in the bid response or the above statement shall prevail. Delivery of substitute commodities requires prior written approval from the ordering location.

Should the device be found to be defective during the warranty period, the Vendor must make the required repairs (1) at the State Materials Office, or (2) replace or repair the defective parts at the Vendor's location(s) and incur all shipping and/or mobilization charges connected with said replacement or repair.

12) REPLACEMENT/RESTOCKING

Replacement of all materials found defective within the warranty period shall be made without cost to the purchaser, including transportation if applicable. All fees associated with restocking cancelled orders shall be the responsibility of the vendor.

13) PRODUCT REQUIREMENTS/SPECIFICATIONS

Any deviation from specifications indicated herein must be clearly pointed out; otherwise, it will be considered that items offered are in strict compliance with these specifications, and successful bidder will be held responsible therefore. Deviations must be explained in detail on separate attached sheet(s).

14) ACCEPTANCE

All items listed in the specifications, delivered to the Department not meeting specifications or found to be poorly manufactured will not be accepted, but returned to the vendor, at their expense, for replacement. Replacement of all items found defective shall be made without cost to the Department, including transportation, if applicable. As it may be impossible for each facility to inspect all items upon arrival, a reasonable opportunity must be given to these facilities for inspection of the items, and returning those that are defective.

15) REVIEW OF BIDDER'S FACILITIES & QUALIFICATIONS

After the bid due date and prior to contract execution, the Department reserves the right to perform or to have performed, an on-site review of the bidder's facilities and qualifications. This review will serve to verify data and representations submitted by the bidder and may be used to determine whether the bidder has adequate facilities, equipment, qualified and experienced staff, and overall management capabilities to provide the required items. The review may also serve to verify whether the bidder has financial capabilities adequate to meet the contract requirements.

Should the Department determine that the bid package has material misrepresentations or that the size or nature of the bidder's facilities, equipment, management capabilities, or the number of experienced personnel (including technical staff) are not adequate to ensure satisfactory contract performance, the Department has the right to reject the bid.

16) PROTEST OF INVITATION TO BID SPECIFICATIONS

Any person who is adversely affected by the contents of this Invitation to Bid must file the following with the Department of Transportation, Clerk of Agency Proceedings, Office of the General Counsel, 605 Suwannee Street, Mail Station 58, Tallahassee, Florida 32399-0450:

1. A written notice of protest within seventy-two (72) hours after the posting of the solicitation (the notice of protest may be Faxed to 850-414-5264), and
2. A formal written protest in compliance with Section 120.57(3), Florida Statutes, within ten (10) days of the date on which the written notice of protest is filed.

Failure to file a protest within the time prescribed in section 120.57(3), Florida Statutes, or failure to post the bond or other security required by law within the time allowed for filing a bond shall constitute a waiver of proceedings under Chapter 120, Florida Statutes.

17) UNAUTHORIZED ALIENS

The employment of unauthorized aliens by any contractor is considered a violation of Section

274A(e) of the Immigration and Nationality Act. If the contractor knowingly employs unauthorized aliens, such violation shall be cause for unilateral cancellation of the contract.

18) SCRUTINIZED COMPANIES LISTS

ALL Responses, regardless of dollar value, must include a completed [Vendor Certification Regarding Scrutinized Companies Lists](#) to certify the respondent is not on either of those lists. The Form should be submitted with the Price Proposal.

A Vendor is ineligible to enter into a contract with the Department for goods or services of any amount if, at the time of entering into such contract, the Vendor is on the Scrutinized Companies that Boycott Israel List, created pursuant to Section 215.4725, Florida Statutes, or is engaged in a boycott of Israel.

Section 287.135, Florida Statutes, also prohibits companies from entering into a contract for goods or services of \$1 million or more that are on either the Scrutinized Companies with Activities in Sudan List or the Scrutinized Companies with Activities in the Iran Petroleum Energy Sector Lists which were created pursuant to s. 215.473, Florida Statutes.

If the Department determines the Vendor submitted a false certification under Section 287.135 of the Florida Statutes, the Department shall either terminate the Contract after it has given the Vendor notice and an opportunity to demonstrate the Department's determination of false certification was in error pursuant to Section 287.135 of the Florida Statutes, or maintain the Contract if the conditions of Section 287.135 of the Florida Statutes are met.

19) RESERVATIONS

The Department reserves the right to accept or reject any or all bids received and reserves the right to make an award without further discussion of the bids submitted. Therefore, the bidder should make sure that the bid package submitted is complete and accurate and submitted to ensure delivery on or before the bid opening time and date specified in this solicitation. It is understood that the bid will become a part of the Department's official file, without obligation to the Department.

20) ADDITIONAL TERMS & CONDITIONS

No conditions may be applied to any aspect of the ITB by the bidder. Any conditions placed on any aspect of the bid documents by the bidder may result in the bid being rejected as a conditional bid (see "RESPONSIVENESS OF BIDS"). **DO NOT WRITE IN CHANGES ON ANY ITB SHEET.** The only recognized changes to the ITB prior to bid opening will be a written Addenda issued by the Department.

21) RESPONSIVENESS OF BIDS

Bids will not be considered if not received by the Department **on or before** the date and time specified as the due date for submission. All bids must be typed or printed in ink. A responsive bid is an offer to provide the items specified in this Invitation to Bid in accordance with all requirements of this Invitation to Bid. Bids found to be non-responsive will not be considered. Bids may be rejected if found to be irregular or not in conformance with the specifications and instructions herein contained. A bid may be found to be irregular or non-responsive by reasons that include, but are not limited to, failure to utilize or complete prescribed forms, modifying the bid specifications, submitting conditional bids or incomplete bids, submitting indefinite or ambiguous bids, or executing forms or the bid sheet with improper and/or undated signatures. Other conditions which may cause rejection of bids include, evidence of collusion among bidders, obvious lack of experience or expertise to provide the required items, and failure to perform or meet financial obligations on previous contracts. ALL determinations of responsiveness will be made by the FDOT Procurement Office.

22) REQUIRED DOCUMENTS

The bidder must use the attached Bid Sheet to submit its bid. The Bid Sheet must be signed and dated in ink by a representative who is authorized to contractually bind the bidder. All bid sheets and other documentation submitted in response to this solicitation must be executed and submitted in a sealed envelope. **Indicate the bid number, with the time and date of the bid opening, on the envelope used to return the bid.**

23) "DRUG-FREE WORK PLACE" PREFERENCE

Whenever two or more bids which are equal with respect to price, quality, and service are received, the Department shall determine the order of award first in accordance with section 295.187(4), Florida Statutes, giving preference to "Veteran Business Enterprise" then to bid responses from vendors that certify the business has implemented a drug-free workplace program in accordance with Section 287.087, Florida Statutes. The "Drug-Free Workplace Program Certification" must be completed and submitted with the bid response to be eligible for this preference.

24) COPYRIGHTED MATERIAL

Copyrighted material will be accepted as part of a bid only if accompanied by a waiver that will allow the Department to make paper and electronic copies necessary for the use of Department staff and agents. It is noted that copyrighted material is not exempt from the Public Records Law, Chapter 119, Florida Statutes. Therefore, such material will be subject to viewing by the public, but copies of the material will not be provided to the public.

25) ATTACHMENT TO ITB SUBMITTAL - CONFIDENTIAL MATERIAL

The Bidder must include any materials it asserts to be exempted from public disclosure under Chapter 119, Florida Statutes, in a separate bound document labeled "Attachment to Invitation to Bid, Number DOT-ITB-20-9088-AJ-Confidential Material". The Bidder must identify the specific Statute that authorizes exemption from the Public Records Law. Any claim of confidentiality on materials the Bidder asserts to be exempt from public disclosure and placed elsewhere in the bid will be considered waived by the Bidder upon submission, effective after opening.

26) MAIL OR DELIVER BIDS TO: (DO NOT FAX OR SEND BY E-MAIL)

**Florida Department of Transportation
Central Procurement Office
Attn: Sherill Johnson, Procurement Office
605 Suwannee Street, Mail Station 20
Tallahassee, Florida 32399-0450
Phone: (850) 414.4381**

It is the bidder's responsibility to assure that the bid is delivered to the proper place **on or before** the Bid Due date and time (See Introduction Section 2 Timeline). Bids which for any reason are not so delivered will not be considered.

27) MODIFICATIONS, RESUBMITTAL AND WITHDRAWAL

Bidders may modify submitted bids at any time prior to the bid due date. Requests for modification of a submitted bid shall be in writing and must be signed by an authorized signatory of the bidder. Upon receipt and acceptance of such a request, the entire bid will be returned to the bidder and not considered unless resubmitted by the due date and time. Bidders may also send a change in a sealed envelope to be opened at the same time as the bid. The ITB number, opening date and time should appear on the envelope of the modified bid.

28) **POSTING OF INTENDED DECISION/AWARD**

28.1 - General:

The Department's decision will be posted on the Florida Vendor Bid System at www.myflorida.com, (click on "BUSINESS", click on "Doing Business with the State", under "Everything for Vendors and Customers", click on "Vendor Bid System (VBS)", on date and time in the Timeline, and will remain posted for a period of seventy-two (72) hours. Any bidder who is adversely affected by the Department's recommended award or intended decision must file the following with the Department of Transportation, Clerk of Agency Proceedings, Office of the General Counsel, 605 Suwannee Street, Mail Station 58, Tallahassee, Florida 32399-0450:

1. A written notice of protest within seventy-two (72) hours after posting of the Intended Award (the notice of protest may be Faxed to 850-414-5264), and
2. A formal written protest and protest bond in compliance with Section 120.57(3), Florida Statutes, within ten (10) days of the date on which the written notice of protest is filed. At the time of filing the formal written protest, a bond (a cashier's check or money order may be accepted) payable to the Department must also be submitted in an amount equal to one percent (1%) of the estimated contract amount based on the contract price submitted by the protestor.

Failure to file a protest within the time prescribed in Section 120.57(3), Florida Statutes, or failure to post the bond or other security required by law within the time allowed for filing a bond shall constitute a waiver of proceedings under Chapter 120, Florida Statutes.

28.2 - Inability to Post:

If the Department is unable to post as defined above, the Department will notify all bidders by electronic notification on the Florida Vendor Bid System (see special condition 28.1, above) or by mail, fax, and/or telephone. The Department will provide notification of any future posting in a timely manner.

28.3 - Request to Withdraw Bid:

Requests for withdrawal will be considered if received by the Department, in writing, within seventy-two (72) hours after the bid opening time and date. Requests received in accordance with this provision will be granted by the Department upon proof of the impossibility to perform based upon obvious error on the part of the bidder. Bidders that do not withdraw as stated above will forfeit their bid bond, if applicable.

29) **AWARD OF THE CONTRACT**

The Department will issue a Purchase Order.

30) **RECYCLED MATERIAL**

The Department encourages the use of products and materials with recycled content and post-consumer recovered materials. If the item(s) specified herein is available with recycled content, we request that you provide product information to help in our search for recycled products. However, this bid request is for the product as specified herein and does not require prices for recycled product unless specified. This information should be sent separately and not as a part of your bid response.

31) ATTACHED FORMS

The Bidder **must** complete all required items below and submit them as part of the Bid package. Any Bid in which these forms are not used or in which these forms are improperly executed may be considered non-responsive and the bid may be subject to rejection.

Bid Sheet

Drug-Free Workplace Program Certification (if applicable)

Vendor Certification Regarding Scrutinized Companies Lists (Form 375-030-60)

In-State Preference Form (375-040-56)

32) TERMS AND CONDITIONS

32.1 General Contract Conditions (PUR 1000)

The State of Florida's General Contract Conditions are outlined in form PUR 1000, which is a downloadable document incorporated into this Invitation to Bid (ITB) by reference. Any terms and conditions set forth in this ITB document will take precedence over the PUR 1000 form where applicable.

<http://www.dms.myflorida.com/content/download/2933/11777/1000.pdf>

The following paragraphs do not apply to this Invitation to Bid:

Paragraph 31, Dispute Resolution - PUR 1000

Paragraph 40, PRIDE – PUR 1000, when federal funds are utilized.

32.2 General Instructions to Respondents (PUR 1001)

The State of Florida's General Instructions to Respondents are outlined in form PUR 1001, which is a downloadable document incorporated into this Invitation to Bid (ITB) by reference. Any terms and conditions set forth in this ITB document take precedence over the PUR 1001 form where applicable.

<http://www.dms.myflorida.com/content/download/2934/11780/1001.pdf>

The following paragraphs do not apply to this Invitation to Bid:

Paragraph 3, Electronic Submission – PUR 1001

Paragraph 4, Terms and Conditions – PUR 1001

Paragraph 5, Questions – PUR 1001

32.3 MFMP Purchase Order Terms and Conditions

All MFMP Purchase Order contracts resulting from this solicitation will include the terms and conditions of this solicitation and the State of Florida's standardized Purchase Order Terms and Conditions, which can be found at the Department of Management Services website at the following link:

http://www.dms.myflorida.com/content/download/117735/646919/Purchase_Order_Terms_Sept_1,_2015_.pdf

Section 8(B), PRIDE, is not applicable when using federal funds.

33) ORDER OF PRECEDENCE

All responses are subject to the terms and conditions of this solicitation, which, in case of conflict, shall have the following order of precedence listed:

Special Conditions

Technical Specification

Bid Sheet

MFMP Purchase Order Terms and Conditions

General Instructions to Respondents (PUR 1001)

General Contract Conditions (PUR 1000)

Introduction Section

EXHIBIT A – TECHNICAL SPECIFICATIONS

FLORIDA DEPARTMENT OF TRANSPORTATION STATE MATERIALS OFFICE

ACQUISITION – ASPHALT BINDER AUTO EXTRACTION DEVICE

DOT-ITB-20-9088-SJ

1.0 SCOPE

The Florida Department of Transportation (FDOT) intends to acquire an asphalt binder auto extraction device for the purposes of improving the safety of this test method. In the use of current equipment, much labor is involved in handling trichloroethylene, which is a hazardous chemical and known carcinogen. Though safety protocols are used, there is always some fume exposure and the possibility of physical contact with the chemical should an accident occur or safety protocols not be followed. The machine to be purchased automates the entire process and significantly minimizes safety hazards, yet meets current ASTM standards. The purpose of this scope is to define the requirements of such a device.

2.0 ASPHALT AUTO EXTRACTION DEVICE SPECIFICATIONS

The device shall satisfy, at a minimum, the following specifications from ASTM D8159 – 19:

1. Device Specifications:

1.1 Automated Extraction Unit, consisting of a fully automated system with a process flow chart equivalent to the one reported in Fig. 1.

1.1.1 The automated extraction system shall be composed of the following components:

1.1.2 Washing Chamber (Fig. 1, #1)—Stainless steel washing chamber fitted with an ultrasonic device, a heating system (Fig. 1, #2), a rotating washing drum, and a closing door with a safety lock.

1.1.3 Inspection Window (Fig. 1, #3)—Transparent window, allowing monitoring of the color of the solvent flowing from the washing chamber to the centrifuge.

1.1.4 Centrifuge (Fig. 1, #4, #5)—Stainless steel centrifuge casing with cover and safety lock. Internal centrifuge spindle capable of accommodating a cup with appropriate geometry and rotating at a speed suitable to ensure the separation between mineral filler passing the designated drum mesh sieve and solvent. To remove mineral filler from the cup after the centrifugation process, a special inlay paper is required inside the cup prior to start of extraction.

1.1.5 Solvent Pump (Fig. 1, #9)—Capable of transferring the solvent from the clean solvent tank to the washing chamber.

1.1.6 Condenser (Fig. 1, #6)—Stainless steel tank with built-in cooling coil for water cooling to condense solvent.

1.1.7 Pump, Air or Vacuum (Fig. 1, #7)—Solvent-resistant pump, able to circulate air and solvent vapors during the drying cycle. The circulation of the air ensures that the solvent vapors are extracted from the specimen and released in the condenser.

1.1.8 Outlet Valve and Recovery Module (Fig. 1, #8, #10-13)—Composed of two chambers and integrated cooling system, capable of adequately recovering solvent from an asphalt mixture. One chamber shall serve as a binder and solvent solution storage chamber, and the other serving as a clean solvent storage and recovery chamber. All chambers shall have the capability to allow transfer of solvent through the extraction process.

1.1.8.1 Solvent Recovery and Binder Storage Chamber, fitted with heating system to distill solvent, fill level indicators to prevent heating when chamber is empty, and an outlet tap.

1.1.8.2 Clean Solvent Storage and Recovery Chamber, fitted with integrated cooling system, fill level indicator, outlet tap, and mechanism to allow solvent distillate to flow or be transferred back to washing chamber.

1.2 Washing Drum—A stainless steel washing drum able to contain the specimen. The cylindrical wall is made of mesh having an aperture of one of the following mesh sizes: 0.063 mm, 0.075 mm, or 0.090 mm. The mesh shall be interchangeable and resistant to wear and impacts from the aggregates during the test. The drum shall have a closing system (lid). The connection between the parts of the drum and the closing lid will ensure the sealing with regards to fine particles. (Any aperture should be smaller than the mesh filtering grade.) The washing drum with lid closed fits into washing chamber in Fig. 1, #1 after being filled with asphalt mixture prior to extraction.

1.3 Centrifuge Cup—A stainless steel cup to collect mineral filler during extraction. The cup is placed empty with inlay paper prior to extraction into the centrifuge chamber in Fig. 1, #4.

1.4 Inlay paper for centrifuge cup shall meet the following specifications: weight: 40 g/m²; pH neutral. Inlay paper suggested size: 383 by 205 mm.

1.5 Human-machine interface (Fig. 1, #14).

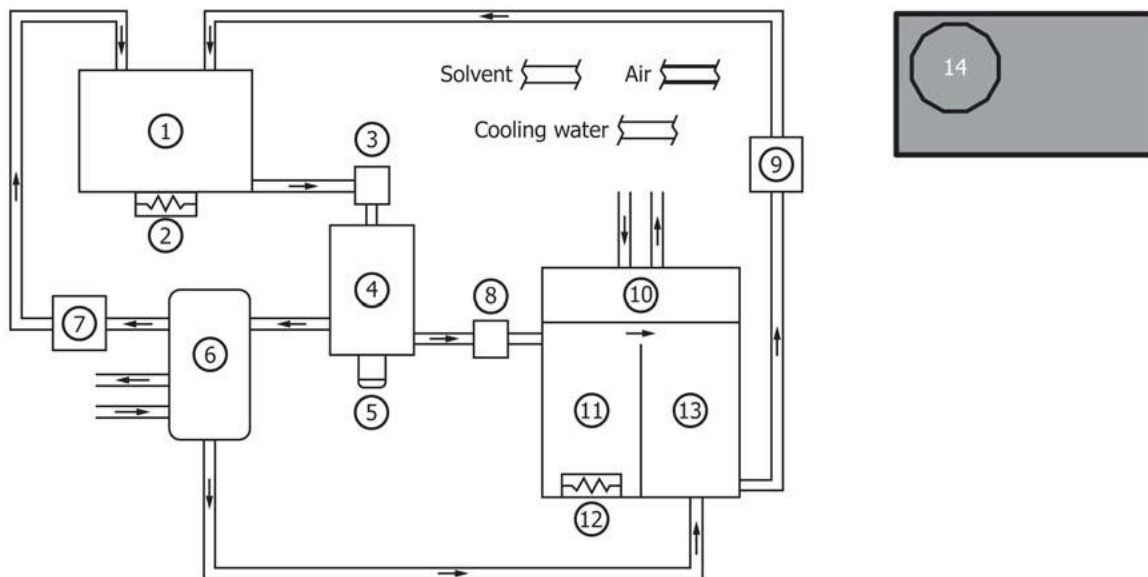

- 1. Washing chamber
- 2. Washing chamber heating system
- 3. Inspection window
- 4. Centrifuge
- 5. Centrifuge motor
- 6. Condenser
- 7. Vacuum or air pump
- 8. Outlet valve
- 9. Solvent pump
- 10. Integrated cooling system
- 11. Extracted binder and solvent solution tank
- 12. Distillation unit heating system for collection and partial solvent recovery
- 13. Clean solvent tank
- 14. Human-machine interface (HMI)

FIG. 1 Schematic Drawing of Automated Extraction Unit

2. The Vendor shall provide at a minimum the following:
 - a. Delivery, unpacking and inspection of the device.
 - b. Device setup.
 - c. Device calibration.
 - d. Demonstration of proper functioning of the unit.
 - e. Training on the use of the unit.
 - f. Training on the maintenance of the unit.
 - g. Provide any other information, document, software, hardware, etc. deemed necessary or required.

3.0 WARRANTY

1. A warranty of all equipment and components must be provided against defects in material and workmanship for a period of not less than 12 months from the date of initial installation and operation at the State Materials Office by the Vendor and acceptance by the Department.
2. Should the device be found to be defective during the warranty period, the Vendor must make the required repairs (1) at the State Materials Office, or (2) replace or repair the defective parts at the Vendor's location(s) and incur all shipping and/or mobilization charges connected with said replacement or repair.

4.0 PLACE OF DELIVERY

The device shall be delivered to the Florida Department of Transportation, State Material Office in Gainesville, Florida, where final acceptance shall occur. The Vendor shall notify the Department of the anticipated delivery date at least 10 business days prior to the delivery due date.

ATTN: Greg Sholar
Florida Department of Transportation
State Materials Office
5007 NE 39th Ave
Gainesville, FL 32609
Phone (352) 955-2920
gregory.sholar@dot.state.fl.us

BID CHECKLIST

(DOES NOT NEED TO BE RETURNED WITH YOUR BID RESPONSE)

This Checklist is provided as a guideline, only, to assist bidders in the preparation of their bid response. Included are some important matters that the bidder should check. This checklist is just a guideline, and is not intended to include all matters required by the ITB. Bidders are responsible to read and comply with the ITB in its entirety.

Check off each the following:

- _____ 1. The "Bid Sheet" has been filled out completely, signed, and enclosed in the bid response.
- _____ 2. The Federal Employers Identification Number or Social Security Number has been entered in the space provided.
- _____ 3. "Drug-Free Workplace Program Certification" form has been read, signed, and enclosed in the bid response, if applicable.
- _____ 4. "Scrutinized Companies Lists" certification form has been read, signed, and enclosed in the bid response.
- _____ 5. The Technical Specifications section has been thoroughly reviewed for compliance to the bid requirements.
- _____ 6. The prices bid have been reviewed for accuracy and all price corrections have been initialed in ink.
- _____ 7. The "In-State Preference" form has been filled out completely and accompanied with a written response from an attorney, if applicable, as outlined in Special Condition 7 and enclosed in the bid response.
- _____ 8. The www.myflorida.com website has been checked and any Addendums posted have been completed, signed, and included in the bid response.
- _____ 9. The bid response must be received, at the location specified, **on or before** the Bid Due Date and Time designated in the ITB.
- _____ 10. On the Lower Left Hand Corner of the Envelope transmitting your bid response, write in the following information:

Bid No.: DOT-ITB-20-9088-SJ

Title: Asphalt Binder Auto Extraction Device

Opening Date & Time: See "TIMELINE" in INTRODUCTION SECTION