

(2) STRUCTURAL PRACTICES FOR EROSION AND SEDIMENT CONTROL

(a) INLET PROTECTION SYSTEM

PURPOSE: ANY OF A NUMBER OF SEDIMENT BARRIERS THAT EITHER PREVENT SEDIMENT FROM ENTERING AN INLET OR TRAP THE SEDIMENTS ONCE THEY ENTER THE INLET.

- (1) TYPICAL APPLICATIONS INCLUDE ROCK BARRIERS, FRAME AND FILTER BARRIERS, CURB INLET "SUMP" BARRIER, CURB INLET DIVERSION BERM, CURB AND GUTTER SEDIMENT CONTAINMENT SYSTEM OR CURB INLET INSET.
- (2) SHOULD BE INSTALLED ONLY WHEN CONSTRUCTION ACTIVITIES ARE ON-GOING AND ONLY WHERE SUMP CONDITIONS EXIST.
- (3) SHOULD NOT BE USED WHEN CONSTRUCTION IS COMPLETE AND SHOULD NOT BE USED IN AREAS WHERE FLOODING COULD ENCROACH INTO THE TRAVEL LANES.

III. OTHER CONTROLS:

(1) WASTE DISPOSAL

- (a) THE CONTRACTOR WILL PROVIDE LITTER CONTROL AND COLLECTION WITHIN THE PROJECT BOUNDARIES DURING CONSTRUCTION ACTIVITIES.
- (b) ALL FERTILIZER AND CHEMICAL CONTAINERS SHALL BE DISPOSED OF BY THE CONTRACTOR ACCORDING TO EPA'S STANDARD PRACTICES AS DETAILED BY THE MANUFACTURER.
- (c) NO SOLID MATERIALS, INCLUDING BUILDING AND CONSTRUCTION MATERIALS, SHALL BE DISCHARGED TO WETLANDS OR BURIED ON SITE.
- (d) ALL SANITARY WASTE WILL BE COLLECTED FROM PORTABLE UNITS BY A LICENSED SANITARY WASTE MANAGEMENT CONTRACTOR AS REQUIRED BY STATE REGULATIONS.

(2) OFF-SITE VEHICLE TRACKING - WILL BE CONTROLLED BY THE FOLLOWING METHODS:

- (a) LOADED HAUL TRUCKS ARE TO BE COVERED BY A TARPULIN AT ALL TIMES.
- (b) EXCESS DIRT ON ROAD WILL BE REMOVED DAILY.

(3) STATE AND FEDERAL REGULATIONS: PERMITS WILL BE REQUIRED FROM THE FOLLOWING AGENCIES:

N/A: PERMIT EXEMPT PROJECT

(4) NON-STORMWATER (INCLUDING SPILL REPORTING)

THE CONTRACTOR WILL PROVIDE THE FDOT WITH AN EROSION AND SEDIMENT CONTROL PLAN THAT WILL INCLUDE SPILL CONTAINMENT, REPORTING, AND RESPONSES. THE PLAN SHALL SPECIFY WHAT MANAGEMENT PRACTICES AND CONTAINMENT METHODS WILL BE USED TO PREVENT POTENTIAL POLLUTANTS (FUEL, LUBRICANTS, HERBICIDES, ETC.) FROM SPILLING ONTO THE SOIL OR INTO THE SURFACE WATERS. IF A SPILL DOES OCCUR, OR IF CONTAMINATED SOIL OR GROUNDWATER IS ENCOUNTERED, CONTACT THE FDOT DISTRICT 5 HAZARDOUS WASTE COORDINATOR AT (386) 943-5000.

IV. MAINTENANCE:

MAINTAIN AND REPAIR ALL EROSION AND SEDIMENT CONTROL DEVICES AND REMOVE EROSION AND SEDIMENT CONTROL DEVICES WHEN NOTICE OF TERMINATION IS MAILED. REMOVE AND PROPERLY DISPOSE OF SEDIMENT BUILDUP THROUGH THE LIFE OF THE INSTALLED EROSION AND SEDIMENT CONTROL DEVICES.

- (1) ALL CONTROL MEASURES WILL BE MAINTAINED DAILY BY THE CONTRACTOR AND ALL MEASURES WILL BE MAINTAINED IN GOOD WORKING ORDER. IF A REPAIR IS NECESSARY, IT WILL BE INITIATED IMMEDIATELY.
- (2) SODDING WILL BE INSPECTED FOR BARE SPOTS, WASHOUTS, AND HEALTHY GROWTH.
- (3) SYNTHETIC BALES SHALL BE MAINTAINED TO ENSURE THEIR USEFULNESS AND NOT BLOCK OR IMPEDE STORMWATER FLOW OR DRAINAGE.
- (4) STABILIZED CONSTRUCTION ENTRANCES SHALL BE MAINTAINED TO PREVENT CLOGGING OF ROCK BEDDING WHICH MAY IMPEDE THE USEFULNESS OF THE STRUCTURE.

V. INSPECTION:

- (1) INSTALL AND MAINTAIN RAIN GAUGES ON THE PROJECT SITE AND RECORD WEEKLY RAINFALL IN ACCORDANCE WITH THE NPDES PERMIT.
- (2) ALL EROSION AND SEDIMENT CONTROL MEASURES WILL BE INSPECTED DAILY BY CONTRACTOR'S PERSONNEL WHO ARE F.D.E.P. CERTIFIED STORMWATER MANAGEMENT INSPECTORS. ALL EROSION CONTROL DEVICES WILL BE INSPECTED WITHIN 24 HOURS OF A RAINFALL EVENT OF 0.5 INCHES OR GREATER.
- (3) COMPLETE ALL SWPPP INSPECTION REPORT FORMS REQUIRED FOR THE NPDES PERMIT.

VI. TRACKING AND REPORTING:

- (1) SUBMIT A WEEKLY REPORT TO THE DEPARTMENT DOCUMENTING THE DAILY INSPECTIONS AND MAINTENANCE OR REPAIRS TO THE EROSION AND SEDIMENT CONTROL DEVICES. MAINTAIN ALL REQUIRED REPORTS AND COMPLETE ALL SWPPP INSPECTION FORMS.
- (2) PREPARATION OF ALL THE CONTRACTOR'S REPORTS OF INSPECTION, MAINTENANCE AND REPAIRS REQUIRED FOR THE CONTROL AND ABATEMENT OF EROSION AND WATER POLLUTION, SHALL BE INCLUDED IN THE INDIVIDUAL COSTS OF THE EROSION AND SEDIMENT CONTROL DEVICES OR LUMP SUM COST OF THE PROJECT.
- (3) USE THE SWPPP CONSTRUCTION INSPECTION REPORT FORM # 650-040-03, FOR DAILY INSPECTIONS.

REVISIONS				ENGINEER OF RECORD: BARRY JAMES SWITZER P.E. NO.: 43422 HNTB CORPORATION 610 CRESCENT EXECUTIVE COURT SUITE 400, LAKE MARY, FL 32746 (407) 805-0355 CERT. OF AUTH. NO. 6500	STATE OF FLORIDA DEPARTMENT OF TRANSPORTATION			SHEET NO.  9
DATE	DESCRIPTION	DATE	DESCRIPTION		ROAD NO.	COUNTY	FINANCIAL PROJECT ID	
					CFRC	ORANGE / SEMINOLE	427956-1-72-27	

**TEMPORARY TRAFFIC CONTROL CONSTRUCTION NOTES**

1. THE EXISTING POSTED SPEEDS SHALL BE MAINTAINED AT ALL TIMES:  
 SR 436- 40 MPH  
 SR 426- 30 MPH  
 SR 527- 30 MPH
2. LANE CLOSURES ARE RESTRICTED TO ACTIVE WORK PERIODS. NO LANE CLOSURES ARE ALLOWED DURING THE FOLLOWING TIMES:  
 SR 436- 6:00 AM TO 11:00 PM  
 SR 426- 5:30 AM TO MIDNIGHT
3. UTILIZE PCMS'S TO NOTIFY THE PUBLIC OF UPCOMING LANE CLOSURES. SIGNS ARE TO BE INSTALLED THREE (3) DAYS IN ADVANCE OF LANE CLOSURES WITH THE FOLLOWING DISPLAYS:

DAILY (NIGHTLY) LANE CLOSURES	MM/DD TO MM/DD
-------------------------------------	----------------------

LOCATION TO BE APPROVED BY THE ENGINEER.

4. NOTIFY LYNX 3 BUSINESS DAYS IN ADVANCE OF LANE CLOSURES AND DETOUR IMPLEMENTATION;  
 KEITH TILLET, 407-254-6207, KTILLET@GOLYNX.COM  
 BRUCE DETWEILER, 407-254-6136, BDETWEILER@GOLYNX.COM

**SR 436 TRAFFIC CONTROL PHASE NOTES**

- PHASE I  
 THE INTENT OF THIS PHASE IS TO CONSTRUCT PAVEMENT MARKINGS AND SIGNAGE.
1. CONSTRUCT THE PROPOSED PAVEMENT MARKINGS UTILIZING INDEX 613 OR 618 AS APPROPRIATE.
  2. CONSTRUCT THE PROPOSED SIGNAGE UTILIZING INDEX 612.

**SR 426 TRAFFIC CONTROL PHASE NOTES**

- PHASE I  
 THE INTENT OF THIS PHASE IS TO CONSTRUCT THE ASPHALT PEDESTRIAN CROSSING, MILL AND RESURFACE THE APPROACH ROADWAY, AND APPLY THE DYNAMIC ENVELOPE PAVEMENT MARKINGS.
1. UTILIZE INDEX 616 TO INSTALL THE REQUIRED EROSION CONTROL MEASURES.
  2. UTILIZE INDICES 616 AND 660 TO MILL AND RESURFACE THE APPROACH ROADWAY.
  3. IMPLEMENT THE TEMPORARY DETOUR TO CONSTRUCT THE DYNAMIC ENVELOPE PAVEMENT MARKINGS. LANE CLOSURE TIMES ARE NOT APPLICABLE TO THE TEMPORARY DETOUR.

**SR 426 TRAFFIC CONTROL PHASE TYPICALS**

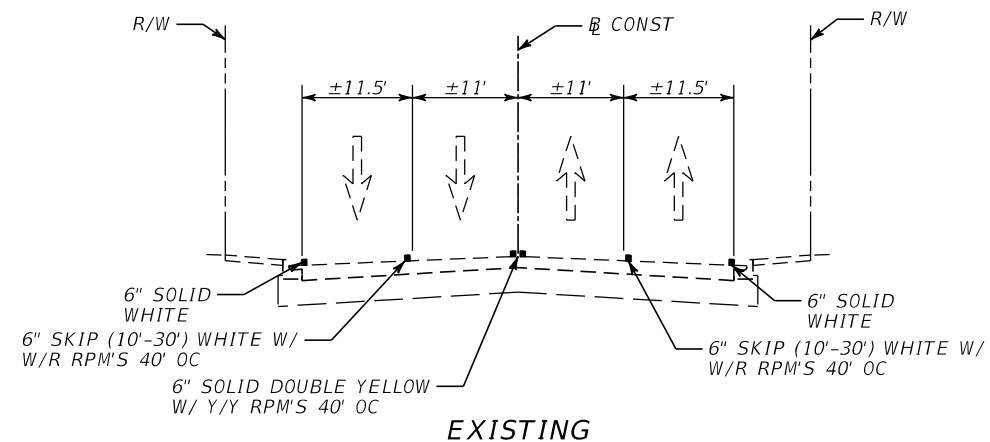

**SR 426 TRAFFIC CONTROL PHASE TYPICALS**

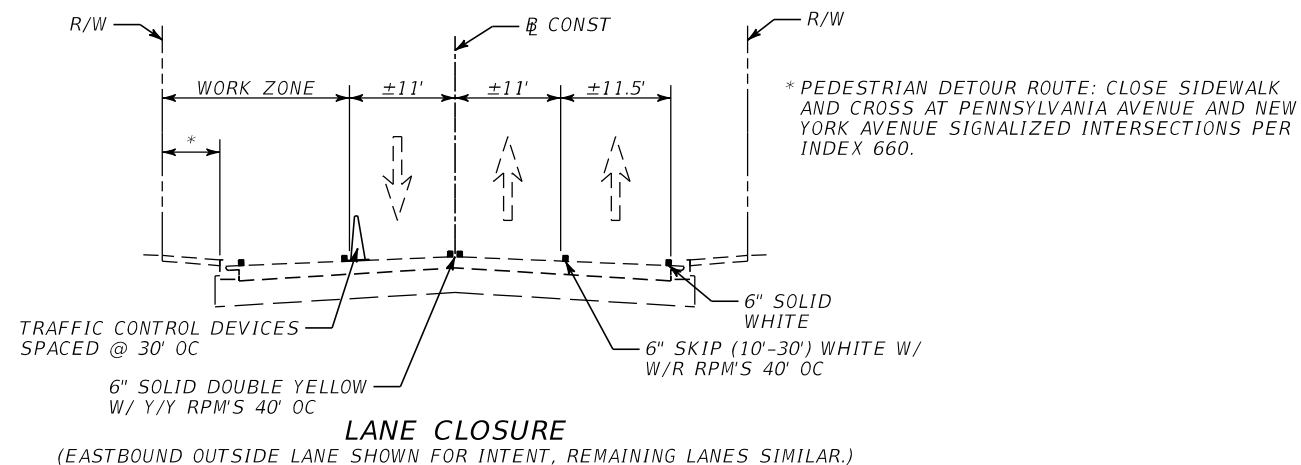

**CONSTRUCTION AND PHASE NOTES**

REVISIONS				ENGINEER OF RECORD: MATTHEW S. ROSS P.E. NO.: 56977 HNTB CORPORATION 610 CRESCENT EXECUTIVE COURT SUITE 400, LAKE MARY, FL 32746 (407) 805-0355 CERT. OF AUTH. NO. 6500	STATE OF FLORIDA DEPARTMENT OF TRANSPORTATION			SHEET NO.  10
DATE	DESCRIPTION	DATE	DESCRIPTION		ROAD NO.	COUNTY	FINANCIAL PROJECT ID	
					CFRC	ORANGE / SEMINOLE	427956-1-72-27	

**TRAFFIC CONTROL PLAN**

THE OFFICIAL RECORD OF THIS SHEET IS THE ELECTRONIC FILE DIGITALLY SIGNED AND SEALED UNDER RULE 61G15-23.004, F.A.C.

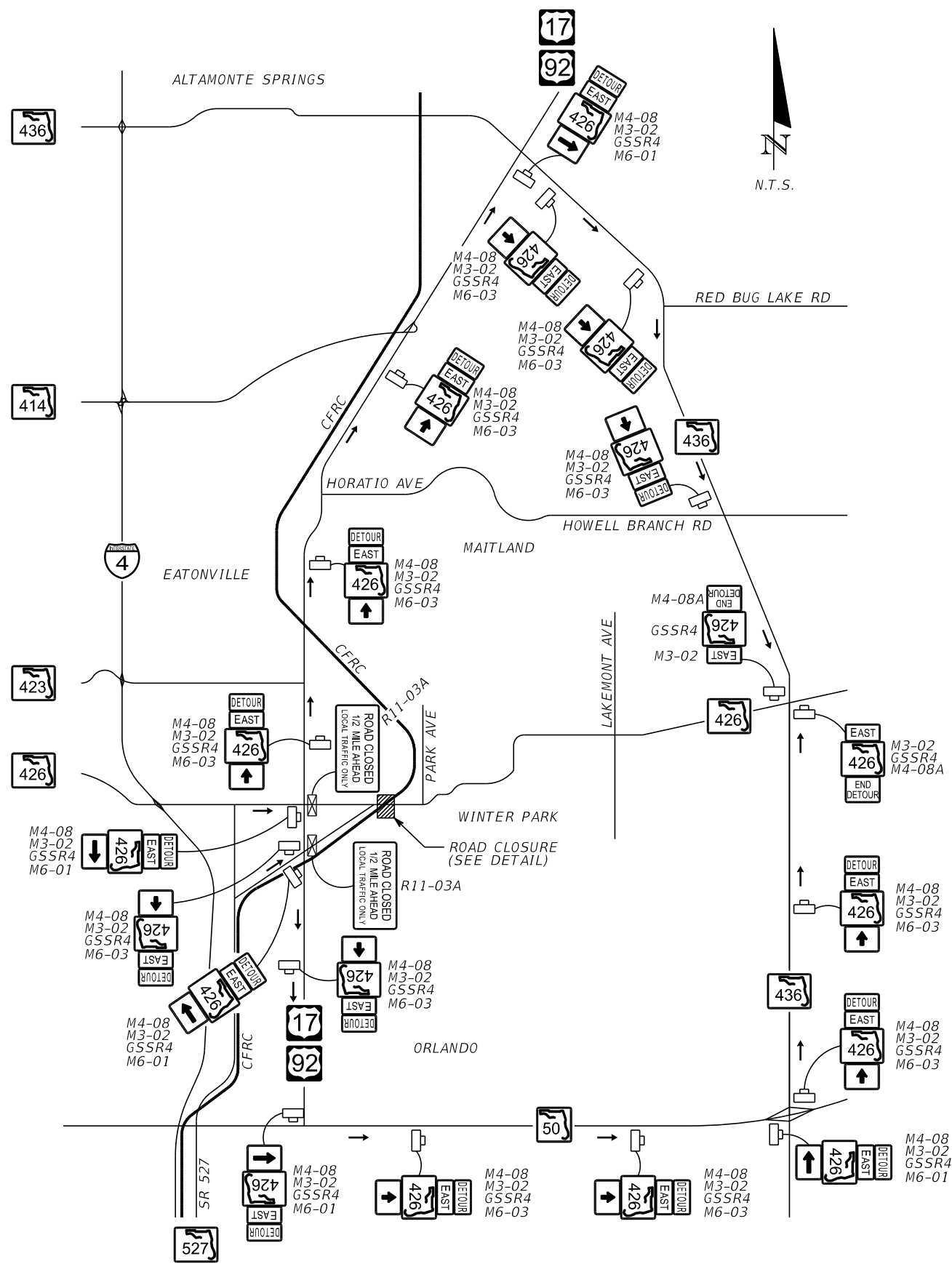

NOTE: EASTBOUND DETOUR, WESTBOUND DETOUR, AND ROAD CLOSURE DETAIL TO BE OPERATED CONCURRENTLY. THE DETOURS HAVE BEEN SEPARATED FOR CLARITY OF INTENT.

**DETOUR NOTES:**

- LANE CLOSURE TIMES NOTED IN THE TRAFFIC CONTROL NOTES ARE NOT APPLICABLE TO THE CLOSURE DETOUR. DAY, TIME AND DURATION ARE TO BE APPROVED BY THE ENGINEER. CLOSURE IS LIMITED TO A 12 HOUR OVERNIGHT MAXIMUM CONTINUOUS WORK PERIOD.
- UTILIZE PCMS TO NOTIFY THE TRAVELING PUBLIC OF UPCOMING DETOUR. SIGNS TO BE INSTALLED SEVEN DAYS IN ADVANCE OF CLOSURE. LOCATION TO BE APPROVED BY THE ENGINEER.



- REDUCE EASTBOUND SR 426 TO ONE THROUGH LANE UTILIZING INDEX 616. MAINTAIN THE LEFT TURN LANE.
- EASTBOUND SR 426 IS TO BE ROUTED SOUTH ON SR 15/ 600 (US 17-92) TO SR 50.
- REDUCE NORTHBOUND SR 527 TO ONE THROUGH LANE UTILIZING INDEX 616. MAINTAIN THE LEFT TURN LANE.
- NORTHBOUND SR 527 IS TO BE ROUTED NORTH ON SR 15/ 600 (US 17-92) TO SR 436.
- TEMPORARILY IMPLEMENT NO ON-STREET PARKING ON HOLT AVENUE FOR DURATION OF DETOUR.
- IMPLEMENT ROAD CLOSURE PER THE DETAIL.
- PROVIDE TRAFFIC CONTROL OFFICER AT THE PENNSYLVANIA AVENUE/SR 426/ORANGE AVENUE INTERSECTION, THE PENNSYLVANIA AVENUE/HOLT AVENUE INTERSECTION, HOLT AVENUE/ NEW YORK AVENUE INTERSECTION, AND THE NEW YORK AVENUE/ SR 426 INTERSECTION TO DIRECT TRAFFIC AND OVERRIDE THE SIGNAL FOR THE DURATION OF THE CLOSURE.
- CONTACT ROLLINS COLLEGE, KEN MILLER AT 407-646-2999, 72 HOURS IN ADVANCE OF IMPLEMENTING THE DETOUR FOR NOTIFICATION.

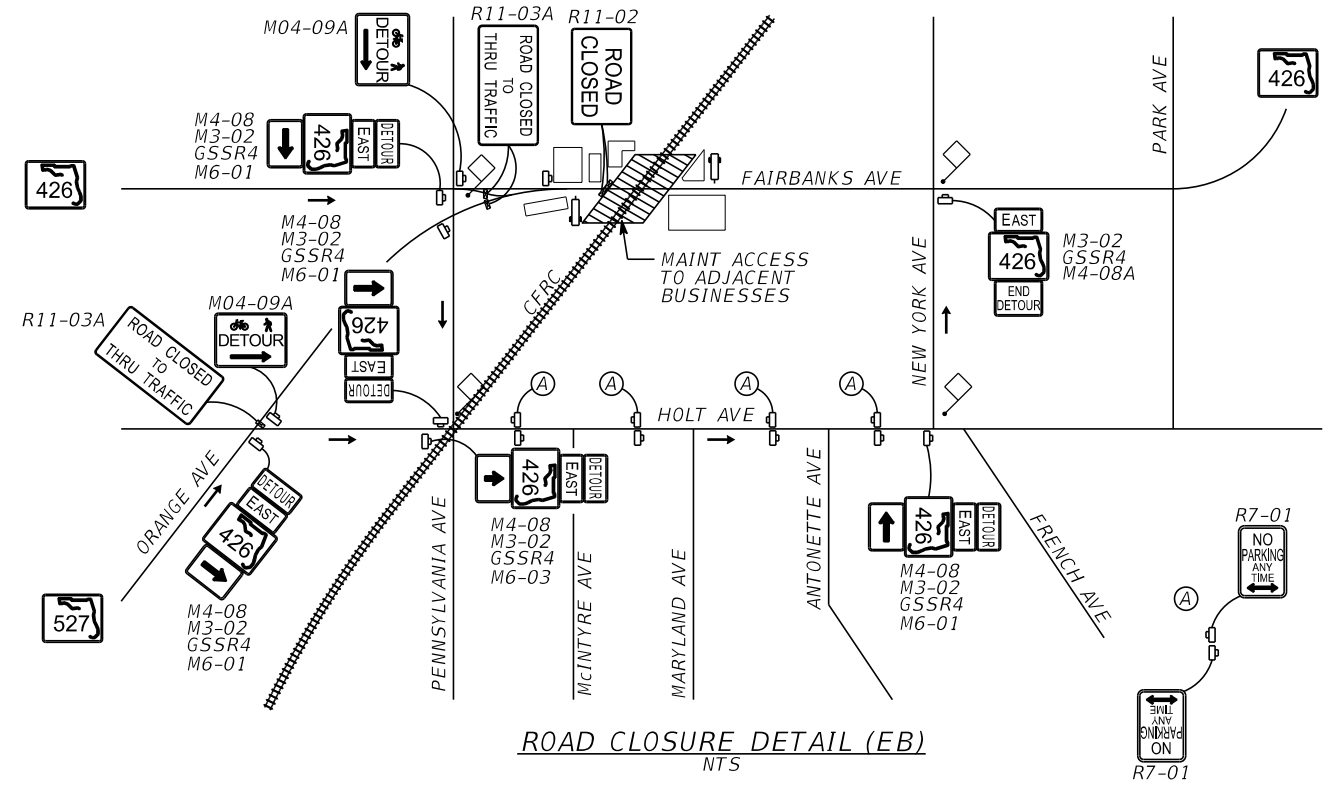

- LEGEND:**
- TRAFFIC CONTROL OFFICER
  - WORK ZONE SIGN
  - TYPE III BARRICADE
  - WORK ZONE
  - DIRECTION OF DETOUR
  - PORTABLE CHANGEABLE (VARIABLE) MESSAGE SIGN (PCMS)

**SR 426 (FAIRBANKS AVENUE)  
EASTBOUND DETOUR**

REVISIONS				ENGINEER OF RECORD: MATTHEW S. ROSS P.E. NO.: 56977 HNTB CORPORATION 610 CRESCENT EXECUTIVE COURT SUITE 400, LAKE MARY, FL 32746 (407) 805-0355 CERT. OF AUTH. NO. 6500	STATE OF FLORIDA DEPARTMENT OF TRANSPORTATION			SHEET NO.  11
DATE	DESCRIPTION	DATE	DESCRIPTION		ROAD NO.	COUNTY	FINANCIAL PROJECT ID	
					CFRC	ORANGE / SEMINOLE	427956-172-27	

THE OFFICIAL RECORD OF THIS SHEET IS THE ELECTRONIC FILE DIGITALLY SIGNED AND SEALED UNDER RULE 61G15-23.004, F.A.C.

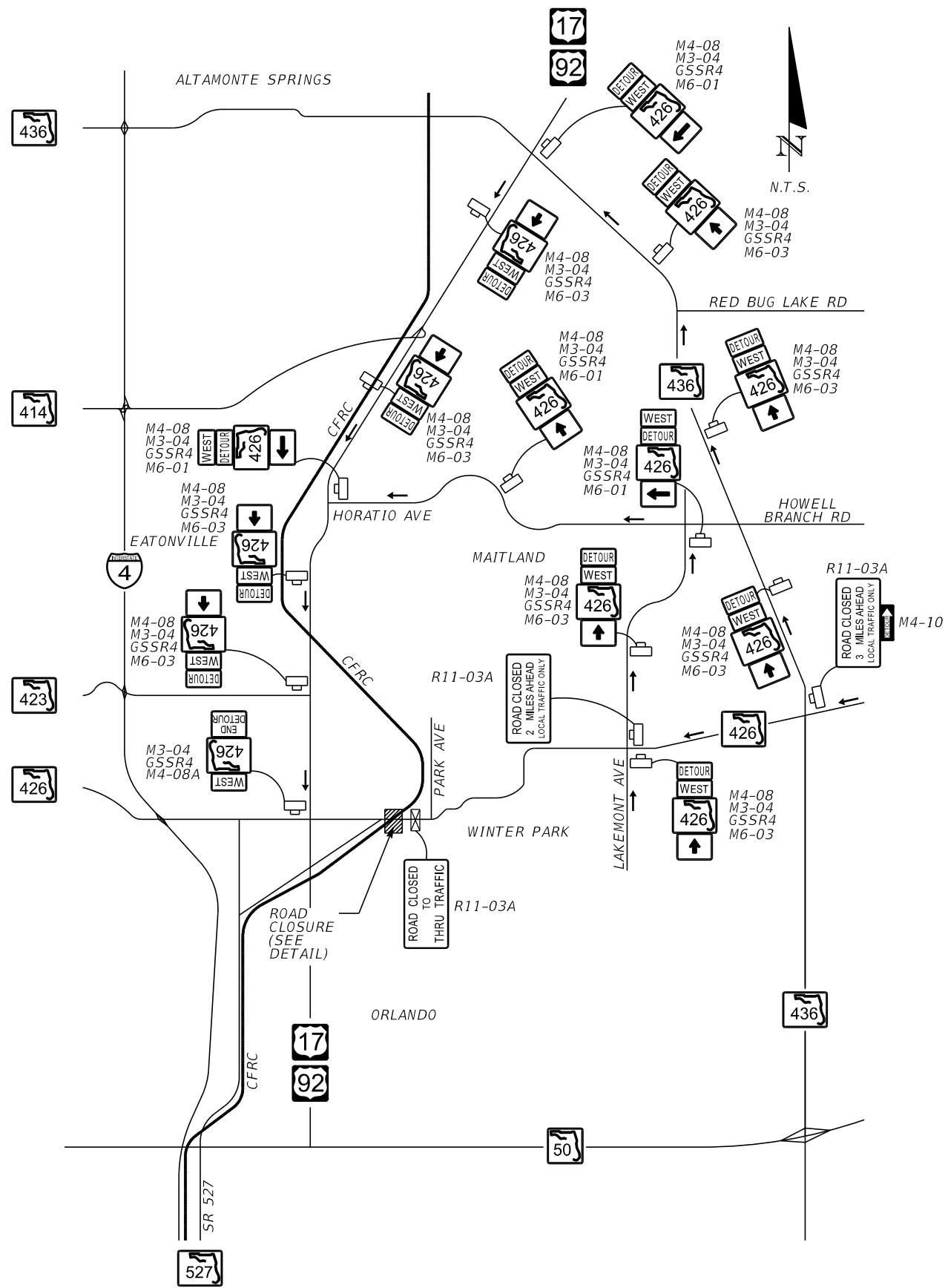

- DETOUR NOTES:**
- LANE CLOSURE TIMES NOTED IN THE TRAFFIC CONTROL NOTES ARE NOT APPLICABLE TO THE CLOSURE DETOUR. DAY, TIME AND DURATION ARE TO BE APPROVED BY THE ENGINEER. CLOSURE IS LIMITED TO A 12 HOUR OVERNIGHT MAXIMUM CONTINUOUS WORK PERIOD.
  - REDUCE WESTBOUND SR 426 TO ONE THROUGH LANE UTILIZING INDEX 616 AT NEW YORK AVENUE. MAINTAIN THE LEFT TURN LANE.
  - WESTBOUND SR 426 IS TO BE ROUTED NORTH ON SR 436 TO 15/ 600 (US 17-92).
  - SUPPLEMENTARY DETOUR TO BE PROVIDED AT LAKEMONT AVENUE. LAKEMONT AVENUE TO BE ROUTED NORTH TO HORATIO AVENUE/ HOWELL BRANCH ROAD.
  - IMPLEMENT ROAD CLOSURE PER THE DETAIL.
  - PROVIDE TRAFFIC CONTROL OFFICER AT THE NEW YORK AVENUE/SR 426 INTERSECTION, NEW YORK AVENUE/ LYMAN AVENUE INTERSECTION AND LYMAN AVENUE/PENNSYLVANIA AVENUE INTERSECTION TO DIRECT TRAFFIC AND OVERRIDE THE SIGNAL FOR THE DURATION OF THE CLOSURE.
  - CONTACT ROLLINS COLLEGE, KEN MILLER AT 407-646-2999, 72 HOURS IN ADVANCE OF IMPLEMENTING THE DETOUR FOR NOTIFICATION.

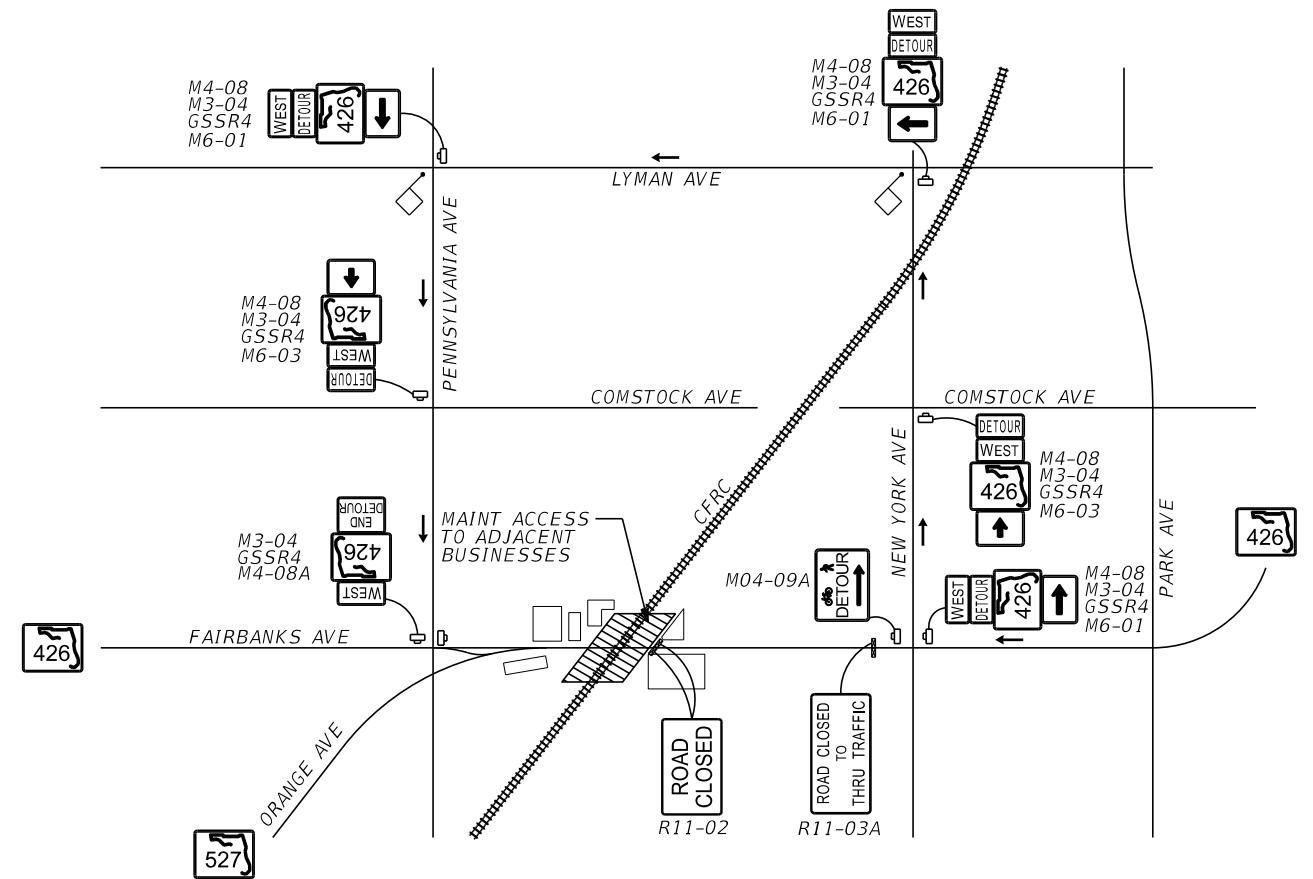

ROAD CLOSURE DETAIL (WB)  
N.T.S.

- LEGEND:**
- ☐ TRAFFIC CONTROL OFFICER
  - ☐ WORK ZONE SIGN
  - ⊘ TYPE III BARRICADE
  - ▨ WORK ZONE
  - ← DIRECTION OF DETOUR

- NORTH M3-01
- EAST M3-02
- SOUTH M3-03
- WEST M3-04

NOTE: EASTBOUND DETOUR, WESTBOUND DETOUR, AND ROAD CLOSURE DETAIL TO BE OPERATED CONCURRENTLY. THE DETOURS HAVE BEEN SEPARATED FOR CLARITY OF INTENT.

**SR 426 (FAIRBANKS AVENUE)  
WESTBOUND DETOUR**

REVISIONS				ENGINEER OF RECORD: MATTHEW S. ROSS P.E. NO.: 56977 HNTB CORPORATION 610 CRESCENT EXECUTIVE COURT SUITE 400, LAKE MARY, FL 32746 (407) 805-0355 CERT. OF AUTH. NO. 6500	STATE OF FLORIDA DEPARTMENT OF TRANSPORTATION			SHEET NO.  12
DATE	DESCRIPTION	DATE	DESCRIPTION		ROAD NO.	COUNTY	FINANCIAL PROJECT ID	
					CFRC	ORANGE / SEMINOLE	427956-172-27	

THE OFFICIAL RECORD OF THIS SHEET IS THE ELECTRONIC FILE DIGITALLY SIGNED AND SEALED UNDER RULE 61G15-23.004, F.A.C.

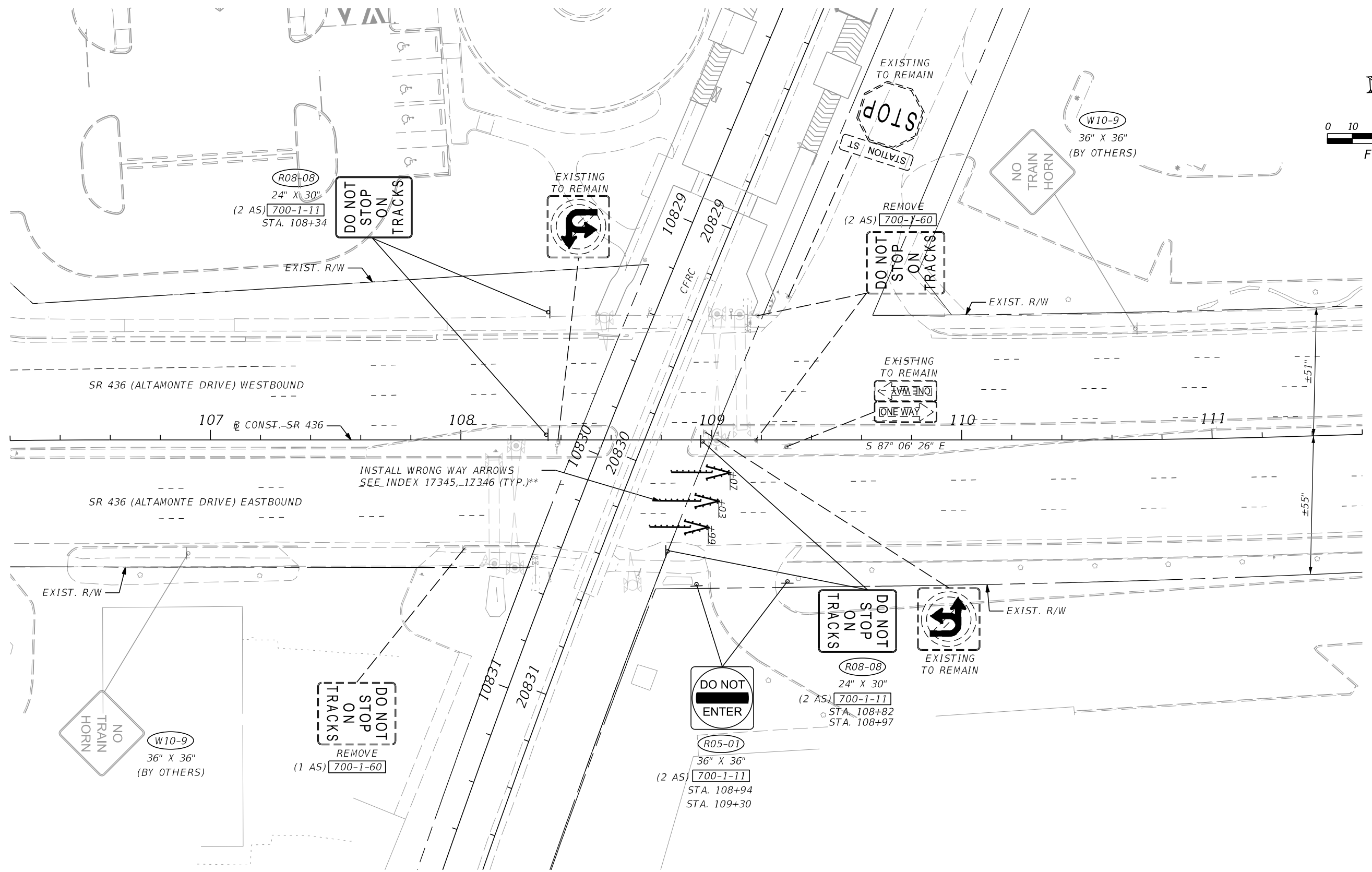
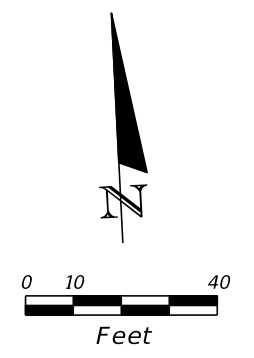

SR 436 (ALTAMONTE DRIVE)

REVISIONS			
DATE	DESCRIPTION	DATE	DESCRIPTION

ENGINEER OF RECORD: STEVEN D. MIKESSELL  
 P.E. NO.: 58703  
 HNTB CORPORATION  
 610 CRESCENT EXECUTIVE COURT  
 SUITE 400, LAKE MARY, FL 32746  
 (407) 805-0355  
 CERT. OF AUTH. NO. 6500

STATE OF FLORIDA DEPARTMENT OF TRANSPORTATION		
ROAD NO.	COUNTY	FINANCIAL PROJECT ID
CFRC	ORANGE / SEMINOLE	427956-1-72-27

**SIGNING AND MARKING PLAN**

SHEET NO.  
13

THE OFFICIAL RECORD OF THIS SHEET IS THE ELECTRONIC FILE DIGITALLY SIGNED AND SEALED UNDER RULE 61G15-23.004, F.A.C.

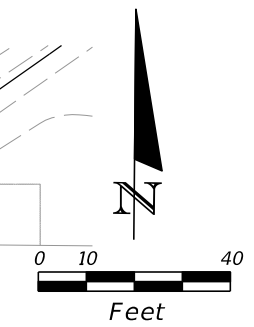
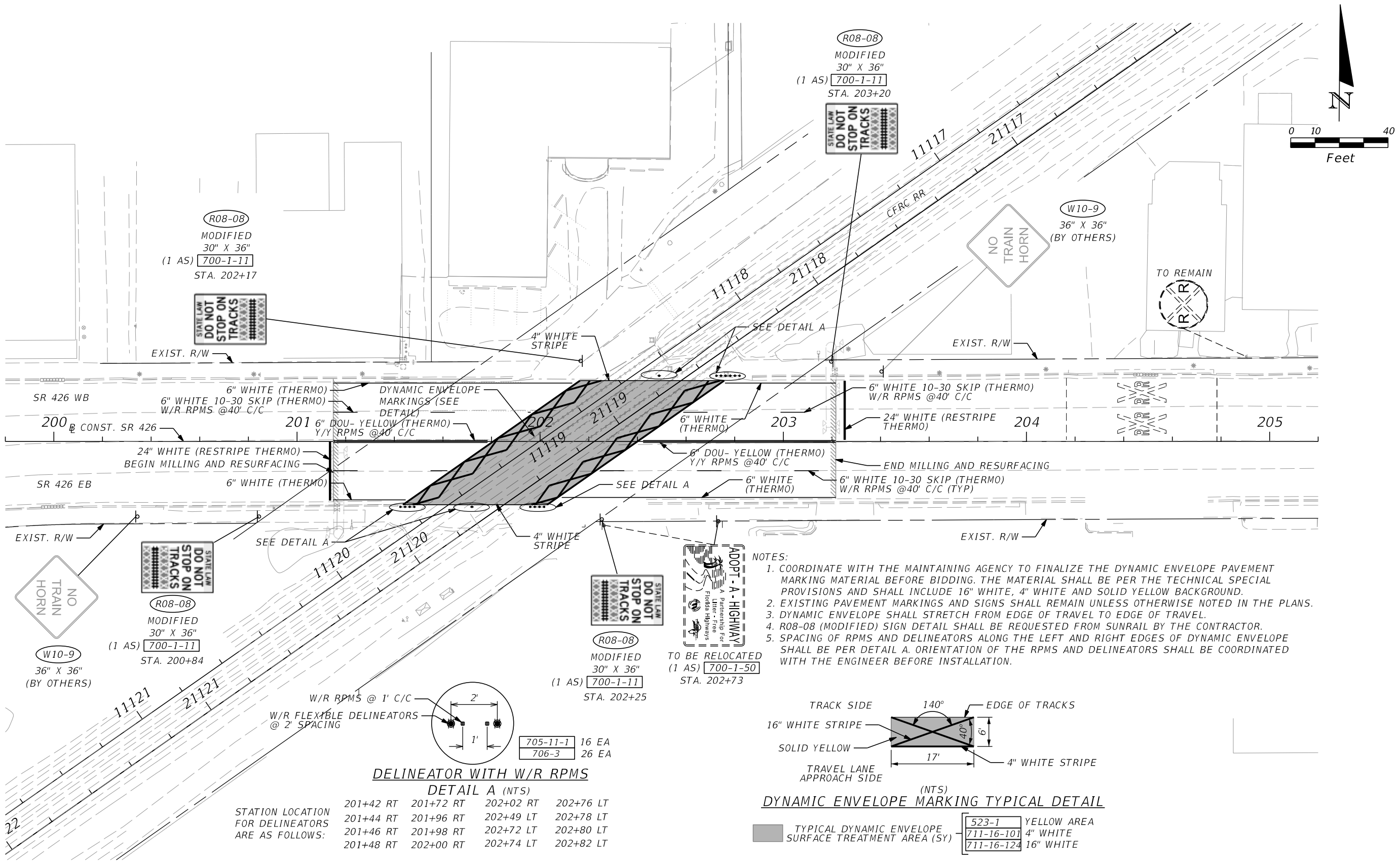

- NOTES:
- COORDINATE WITH THE MAINTAINING AGENCY TO FINALIZE THE DYNAMIC ENVELOPE PAVEMENT MARKING MATERIAL BEFORE BIDDING. THE MATERIAL SHALL BE PER THE TECHNICAL SPECIAL PROVISIONS AND SHALL INCLUDE 16" WHITE, 4" WHITE AND SOLID YELLOW BACKGROUND.
  - EXISTING PAVEMENT MARKINGS AND SIGNS SHALL REMAIN UNLESS OTHERWISE NOTED IN THE PLANS.
  - DYNAMIC ENVELOPE SHALL STRETCH FROM EDGE OF TRAVEL TO EDGE OF TRAVEL.
  - R08-08 (MODIFIED) SIGN DETAIL SHALL BE REQUESTED FROM SUNRAIL BY THE CONTRACTOR.
  - SPACING OF RPMS AND DELINEATORS ALONG THE LEFT AND RIGHT EDGES OF DYNAMIC ENVELOPE SHALL BE PER DETAIL A. ORIENTATION OF THE RPMS AND DELINEATORS SHALL BE COORDINATED WITH THE ENGINEER BEFORE INSTALLATION.

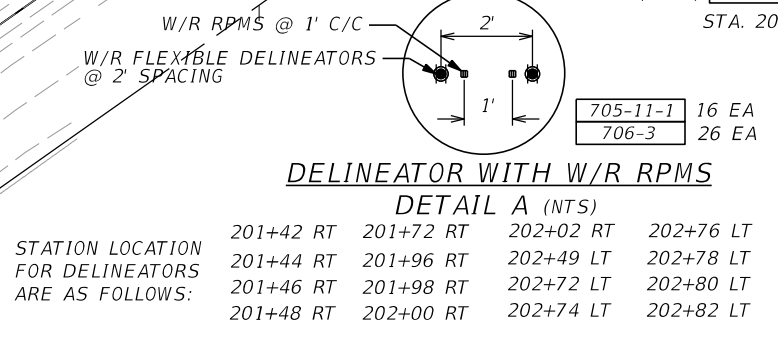
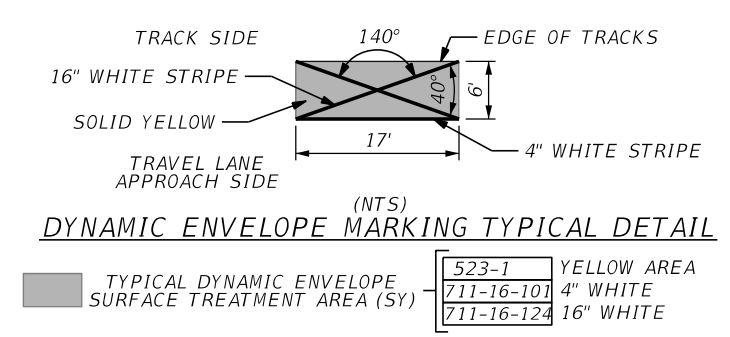

SR 426 (FAIRBANKS AVENUE)

REVISIONS				ENGINEER OF RECORD: STEVEN D. MIKESSELL P.E. NO.: 58703 HNTB CORPORATION 610 CRESCENT EXECUTIVE COURT SUITE 400, LAKE MARY, FL 32746 (407) 805-0355 CERT. OF AUTH. NO. 6500	STATE OF FLORIDA DEPARTMENT OF TRANSPORTATION			SHEET NO.  14
DATE	DESCRIPTION	DATE	DESCRIPTION		ROAD NO.	COUNTY	FINANCIAL PROJECT ID	
					CFRC	ORANGE / SEMINOLE	427956-1-72-27	

THE OFFICIAL RECORD OF THIS SHEET IS THE ELECTRONIC FILE DIGITALLY SIGNED AND SEALED UNDER RULE 61G15-23.004, F.A.C.

November 15, 2017  
PREPARED BY: Victor A. LoPiccolo  
Matthew S. Ross, P.E.



SPECIFICATIONS PACKAGE  
FINANCIAL PROJECT ID(S).427956-1-72-27

SUNRAIL QUIET ZONES

DISTRICT FIVE  
ORANGE & SEMINOLE COUNTIES

The July 2017 Edition of the Florida Department of Transportation Standard Specifications is revised as follows:

*I hereby certify that this specifications package has been properly prepared by me, or under my responsible charge, in accordance with procedures adopted by the Florida Department of Transportation.*

The official record of this package has been electronically signed and sealed using a Digital Signature as required by 61G15-23.004 F.A.C. Printed copies of this document are not considered signed and sealed and the signature must be verified on any electronic copies.

Prepared by: Matthew S. Ross, P.E  
Date: November 15, 2017  
Fla. License No.: 56977  
Firm Name: HNTB Corporation  
Firm Address: 610 Crescent Executive Ct, Suite 400  
City, State, Zip Code: Lake Mary, Florida 32746  
Certificate of Authorization Number: 6500  
Page(s): 1-50

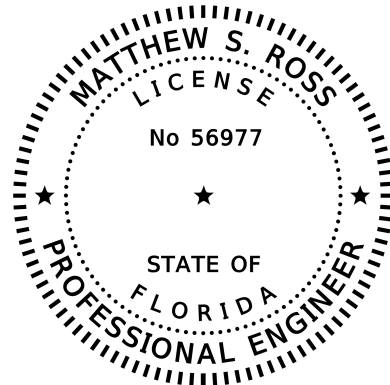

<b>SPECIAL PROVISIONS .....</b>	<b>4</b>
DEFINITIONS AND TERMS. ....	5
PROPOSAL REQUIREMENTS AND CONDITIONS – PREQUALIFICATION OF BIDDERS.....	6
PROPOSAL REQUIREMENTS AND CONDITIONS - EXAMINATION OF CONTRACT DOCUMENTS AND SITE OF WORK. ....	7
AWARD AND EXECUTION OF CONTRACT.....	7
AWARD AND EXECUTION OF CONTRACT – AWARD OF CONTRACT.....	8
AWARD AND EXECUTION OF CONTRACT – PUBLIC RECORDS. ....	8
SCOPE OF THE WORK.....	8
CONTROL OF THE WORK.....	10
CONTROL OF MATERIALS. ....	11
LEGAL REQUIREMENTS AND RESPONSIBILITY TO THE PUBLIC – OPERATIONS WITHIN THE RAILROAD RIGHT-OF-WAY.....	11
UTILITY WORK.....	13
LEGAL REQUIREMENTS AND RESPONSIBILITY TO THE PUBLIC – CONTRACTOR’S RESPONSIBILITY FOR WORK.....	14
EQUAL EMPLOYMENT OPPORTUNITY REQUIREMENTS. ....	14
LEGAL REQUIREMENTS AND RESPONSIBILITY TO THE PUBLIC – E-VERIFY.....	16
PROSECUTION AND PROGRESS – SUBLETTING OR ASSIGNING OF CONTRACTS. ....	16
PROSECUTION AND PROGRESS.....	17
PROSECUTION AND PROGRESS –DISPUTES REVIEW BOARD.....	17
PROSECUTION AND PROGRESS.....	21
PROSECUTION AND PROGRESS - EQUIPMENT.....	21
PROSECUTION AND PROGRESS – CONTRACT TIME EXTENSIONS.....	22
DAMAGE RECOVERY.....	27
MEASUREMENT AND PAYMENT – SCOPE OF PAYMENTS.....	27
CONSTRUCTION EQUIPMENT - GENERAL REQUIREMENTS. ....	30
MAINTENANCE OF TRAFFIC.....	30
LANDSCAPE SOIL LAYER.....	31
RAISED RETRO-REFLECTIVE PAVEMENT MARKERS AND BITUMINOUS ADHESIVE.....	31
THERMOPLASTIC PAVEMENT MARKINGS – HOT SPRAY.....	32
TRAFFIC MARKING MATERIALS – THERMOPLASTIC MATERIAL – HOT SPRAY.....	34
<b>SUPPLEMENTAL SPECIFICATIONS .....</b>	<b>37</b>
001    DEFINITIONS AND TERMS.....	38
002    PROPOSAL REQUIREMENTS AND CONDITIONS.....	38



<b>APPENDICES.....</b>	<b>40</b>
TECHNICAL SPECIAL PROVISIONS.....	41
DYNAMIC ENVELOPE PATTERNED PAVEMENT AT RAILROAD CROSSINGS .....	42
<b>THIS COMPLETES THIS SPECIFICATIONS PACKAGE .....</b>	<b>50</b>

# **SPECIAL PROVISIONS**

## **DEFINITIONS AND TERMS.**

**(REV. 2-25-16) (7-17)**

ARTICLE 1-3. The definition of ‘Contract Documents’ is deleted and replaced by the following:

### **Contract Documents.**

The term “Contract Documents” includes: Advertisement for Proposal, Proposal, Certification as to Publication and Notice of Advertisement for Proposal, Appointment of Agent by Nonresident Contractors, Noncollusion Affidavit, Warranty Concerning Solicitation of the Contract by Others, Resolution of Award of Contract, Executed Form of Contract, Performance Bond and Payment Bond, Specifications, Plans (including revisions thereto issued during construction), Addenda, or other information mailed or otherwise transmitted to the prospective bidders prior to the receipt of bids, work orders and supplemental agreements, work documents, all of which are to be treated as one instrument whether or not set forth at length in the form of contract.

Note: As used in Sections 2 and 3 only, Contract Documents do not include work orders, and supplementary agreements. As used in Section 2 only, Contract Documents also do not include Resolution of Award of Contract, Executed Form of Contract, and Performance and Payment Bond.

ARTICLE 1-3. The definition of ‘Engineer’ is deleted and replaced by the following:

### **Engineer.**

The Director, Office of Maintenance, acting directly or through duly authorized representatives; such representatives acting within the scope of the duties and authority assigned to them.

Note: In order to avoid cumbersome and confusing repetition of expressions in these Specifications, it is provided that whenever anything is, or is to be done, if, as, or, when, or where “acceptable, accepted, approval, approved, authorized, condemned, considered necessary, contemplated, deemed necessary, designated, determined, directed, disapproved, established, given, indicated, insufficient, ordered, permitted, rejected, required, reserved, satisfactory, specified, sufficient, suitable, suspended, unacceptable, or unsatisfactory,” it shall be understood as if the expression were followed by the words “by the Engineer,” “to the Engineer,” or “of the Engineer.”

ARTICLE 1-3. The definition of “Plans” is deleted and replaced by the following

### **Plans.**

The approved plans, including reproductions thereof, showing the location, character, dimensions, and details of the work.

In this contract, references to “the plans” mean the Department’s Design Standards, and revisions thereto current at the time of contract letting, unless otherwise directed in the Contract Documents. When plans are included as part of this contract, references in this contract to “the plans” mean such plans and the Department’s Design Standards, and revisions thereto current at the time of contract letting, unless otherwise directed in the Contract Documents.

ARTICLE 1-3 is expanded by the following

**Work Document.**

Work Documents identify the location, description, amount of work to be accomplished, and time allotted to complete the work.

**PROPOSAL REQUIREMENTS AND CONDITIONS – PREQUALIFICATION OF BIDDERS.**

**(REV 3-15-16) (7-17)**

ARTICLE 2-1 is deleted and the following substituted:

**2-1 Contractor Experience.**

The Department does not require a Contractor to have a certificate of qualification if bidding Maintenance contracts. Maintenance contracts may require potential bidders to have and document certain experience in the type of work required for the contract. If this requirement is applicable to a contract, detailed experience requirements will be listed in the advertisement and a form will be included with the bid package to document such experience. The form must be fully and accurately completed by the potential bidder and received by the Department before or at the opening of the bids.

A person or affiliate who has been placed on the convicted vendor list following a conviction for a public entity crime may not submit the following:

1. A bid on a Contract to provide any goods or services to a public entity.
2. A bid on a Contract with a public entity for the construction or repair of a public building or public work.
3. Bids on leases of real property to a public entity.

A person or affiliate who has been placed on the convicted vendor list following a conviction for a public entity crime may not be awarded or perform work as a contractor, supplier, subcontractor, or consultant under a contract with any public entity, and may not transact business with any public entity in excess of the threshold amount provided in Section 287.017 F.S., for Category Two. All restrictions apply for a period of 36 months from the date of placement on the convicted vendor list.

**PROPOSAL REQUIREMENTS AND CONDITIONS - EXAMINATION OF CONTRACT DOCUMENTS AND SITE OF WORK.**

**(REV 11-3-15) (FA 1-27-16) (7-17)**

ARTICLE 2-4 is deleted and the following substituted:

**2-4 Examination of Contract Documents and Site of Work.**

Examine the Contract Documents and the site of the proposed work carefully before submitting a Proposal for the work contemplated. Investigate the conditions to be encountered, as to the character, quality, and quantities of work to be performed and materials to be furnished and as to the requirements of all Contract Documents.

Direct all questions to the Department by posting them to the Department's website at the following URL address:  
<https://fdotwp1.dot.state.fl.us/BidQuestionsAndAnswers/Proposal.aspx/SearchProposal>. Questions posted to this site before 5:00 P.M. (EST) on the seventh calendar day prior to the bid opening, or tenth calendar day prior to the December bid opening, will be responded to by the Department. For questions posted after these times, an answer cannot be assured. For all questions posted before the deadline, the Department will provide and post responses at the same website before 8:00 A.M. (EST) on the second calendar day prior to bid opening. Take responsibility to review and be familiar with all questions and responses posted to this website and to make any necessary adjustments in the proposal accordingly. If the Department's web site cannot be accessed, contact District 5 Construction Office by email [D5-Bid\\_Questions@dot.state.fl.us](mailto:D5-Bid_Questions@dot.state.fl.us).

When, in the sole judgment of the Department, responses to questions require plans revisions, specifications revisions and/or addenda, the Contracts Office will issue them as necessary.

The Department does not guarantee the details pertaining to borings, as shown in the Plans, to be more than a general indication of the materials likely to be found adjacent to holes bored at the site of the work, approximately at the locations indicated. The Bidder shall examine boring data, where available, and make their own interpretation of the subsoil investigations and other preliminary data, and shall base their bid solely on their own opinion of the conditions likely to be encountered.

The Bidder's submission of a Proposal is prima facie evidence that the Bidder has made an examination as described in this Article.

**AWARD AND EXECUTION OF CONTRACT.**

**(REV 8-1-00) (7-17)**

ARTICLE 3-1. The first paragraph is deleted and the following substituted:

For the purpose of award, after opening and reading the Proposals, the Department will consider the total Contract Lump Sum Price as the bid. On this basis, the Department will compare the amounts of each bid and make the results of such comparison available to the public. Until the actual award of the Contract, however, the Department reserves the right to reject any or all Proposals and to waive technical errors

that the Department determines, in its sole discretion, to be in the best interest of the State. In the event of any discrepancy in the two entries of the Contract Lump Sum Price, the Department will evaluate the bid based on the lump sum price shown in words.

**AWARD AND EXECUTION OF CONTRACT – AWARD OF CONTRACT.  
(REV. 4-27-16) (7-17)**

SUBARTICLE 3-2.2 is deleted.

**AWARD AND EXECUTION OF CONTRACT – PUBLIC RECORDS.  
(REV 10-17-16) (FA 10-24-16) (7-17)**

ARTICLE 3-9 is expanded by the following:

**IF THE CONTRACTOR HAS QUESTIONS REGARDING THE APPLICATION OF CHAPTER 119, FLORIDA STATUTES, TO THE CONTRACTOR'S DUTY TO PROVIDE PUBLIC RECORDS RELATING TO THIS CONTRACT, CONTACT THE CUSTODIAN OF PUBLIC RECORDS AT:**

**District 5  
386-943-5000  
[D5prcustodian@dot.state.fl.us](mailto:D5prcustodian@dot.state.fl.us)  
Florida Department of Transportation  
District 5 – Office of General Counsel  
719 South Woodland Boulevard  
Deland, FL 32720**

**SCOPE OF THE WORK.  
(REV 2-15-17) (7-17)**

ARTICLE 4-1 is deleted and the following substituted:

**4-1 Intent and Scope.**

The work under this Contract consists of the installation of special striping and signage at SunRail crossings on SR 426 and SR 436.

This is a Lump Sum Contract with only one pay item listed in the Contract.

All references to payment under individual pay item numbers, regardless of where those references are contained in the Contract Documents or when in time any such pay item reference is incorporated in the Contract Documents, are superseded by the pay item references in this Special Provision.

Payment for all work in this Contract will be made under:

Item No. 0999-2 Lump Sum Contract - LS

Pay adjustments as shown in the Contract Documents, regardless of where those pay adjustments are referenced, shall not apply, except as provided for in 9-2 Scope of Payments.

SUBARTICLE 4-3.1 is deleted and the following substituted:

**4-3.1 General:** The Engineer reserves the right to make, at any time prior to or during the progress of the work, alterations or changes, whether a significant change or not, and such alterations in the details of construction, whether a substantial change or not, including but not limited to alterations in the grade or alignment of the road or structure or both, as may be found necessary or desirable by the Engineer. Such alterations or changes shall not constitute a breach of Contract, shall not invalidate the Contract, nor release the Surety from any liability arising out of this Contract or the Surety bond. The Contractor agrees to perform the work, as altered or changed, the same as if it had been a part of the original Contract.

The term “significant change” applies only when the Engineer determines that the character of the work as altered differs materially in kind or nature from that involved or included in the original proposed construction. The allowance due to the Contractor will be in accordance with 4-3.2, below.

In the instance of an alleged “significant change”, the determination by the Engineer shall be conclusive and shall not be subject to challenge by the Contractor in any forum, except upon the Contractor establishing by clear and convincing proof that the determination by the Engineer was without any reasonable and good-faith basis.

SUBARTICLE 4-3.4 is deleted and the following substituted:

**4-3.4 Conditions Requiring a Supplemental Agreement or Unilateral Payment:** A Supplemental Agreement or Unilateral Payment will be used to clarify the Plans and Specifications of the Contract; to provide for Unforeseen Work, grade changes, or alterations in Plans which could not reasonably have been contemplated or foreseen in the Original Plans and Specifications; to change the limits of construction to meet field conditions; to provide a safe and functional connection to an existing pavement; to settle documented Contract claims; to make the project functionally operational in accordance with the intent of the original Contract and subsequent amendments thereto.

SUBARTICLE 4-3.9.4 is deleted and the following substituted:

**4-3.9.4 Processing Procedures:** Submit Proposals to the Engineer or his duly authorized representative. The Department will process Proposals expeditiously; however, the Department is not liable for any delay in acting upon a Proposal submitted

pursuant to this Subarticle. The Contractor may withdraw, in whole or in part, a Proposal not accepted by the Department within the period specified in the Proposal. The Department is not liable for any Proposal development cost in the case where the Department rejects or the Contractor withdraws a Proposal.

The Engineer is the sole judge of the acceptability of a Proposal and of the estimated net savings in construction costs from the adoption of all or any part of such Proposal.

Prior to approval, the Engineer may modify a Proposal, with the concurrence of the Contractor, to make it acceptable. If any modification increases or decreases the net savings resulting from the Proposal, the Department will determine the Contractor's fair share upon the basis of the Proposal as modified. The Department will compute the net savings by subtracting the revised total cost affected by the Proposal from the total cost as represented in the original Contract.

Prior to approval of the Proposal that initiates the supplemental agreement, submit acceptable Contract-quality plan sheets revised to show all details consistent with the Proposal design.

## **CONTROL OF THE WORK.**

**(REV 3-15-02) (7-17)**

SUBARTICLE 5-1.1 is expanded by the following:

All reference to separate payment for individual items of work will not apply. The cost for various items of work will be included and paid for under the Contract Lump Sum Price.

ARTICLE 5-2. The first paragraph is deleted and the following substituted:

These Specifications, the Plans, Special Provisions, and all supplementary documents are integral parts of the Contract; a requirement occurring in one is as binding as though occurring in all. In addition to the work and materials specifically called for in the Contract Documents and any additional incidental work, not specifically mentioned, when so shown in the Plans, or if indicated, or obvious and apparent, as being necessary for the proper completion of the work will be included in the Contract Lump Sum Price.

SUBARTICLE 5-7.6 is deleted.



## **CONTROL OF MATERIALS.**

**(REV 8-17-09) (FA 8-24-09) (7-17)**

ARTICLE 6-1 is expanded by the following new Subarticles:

**6-1.3.3 Lump Sum Project General Requirements:** Material is accepted by material sampling and testing requirements for the following work activities: earthwork and related operations, base courses, hot bituminous mixtures, portland cement concrete, and reinforcing steel as stated in 105-2. Fabricated metal acceptance will be in accordance with 105-1.2.3. All other material acceptance will be in accordance with 6-1.

**6-1.3.4 Certification on Approved Product List (APL) Products:** Submit to the Engineer a notarized manufacturer's certification on each APL product that will be incorporated in the project. Submit the certification prior to utilization of the material on the project. Each certification will have the manufacturer letterhead, product name, batch number, FPID, Contract Number, category, county, title of certification person and test results in each product listed in the Department Specification. This letter will also provide the following statement: "This product meets the material specifications as provided in the Contract Documents." Ensure that the date of the manufacturer's certification is current to the shelf life of the product. This letter will be delivered to the jobsite prior to placement or utilization. Retain test results for a minimum of three years.

**6-1.3.5 Certification on all Other Materials Not Specified:** Submit to the Engineer a notarized manufacturer's certification on each product that will be incorporated in the project. Submit the certification prior to utilization on the project. Each certification will have the manufacturer letterhead, identification and type of material, FPID, Contract Number, county, test results of the material and notarized signature from the manufacturer. This letter will also provide the following statement: "This product meets the material specifications as provided in the Contract Documents." Ensure that the date of the manufacturer's certification is current to the shelf life of the product. Retain test results for a minimum of three years.

## **LEGAL REQUIREMENTS AND RESPONSIBILITY TO THE PUBLIC – OPERATIONS WITHIN THE RAILROAD RIGHT-OF-WAY.**

**(REV 3-11-16) (FA 8-2-16) (7-17)**

SUBARTICLE 7-11.4 is deleted and the following substituted:

### **7-11.4 Operations Within Railroad Right-of-Way:**

#### **7-11.4.1 Notification to the Railroad Company:**

**7-11.4.1.1 CSX Transportation (CSXT), Norfolk Southern (NS), and Department-Owned Rail Corridors:** Submit written notification to the Engineer at least 72 hours before beginning any operation within the limits of the railroad right-of-way; any operation requiring movement of employees, trucks, or other equipment across the tracks of the railroad company at other than an established public crossing; and any other work that may affect railroad operations or property.

**7-11.4.1.2 Florida East Coast Railway (FEC):** Submit written notification to the Chief FEC Engineer or authorized Railway Representative at least 72 hours before beginning any operation within the limits of the railroad right-of-way; any operation requiring movement of employees, trucks, or other equipment across the tracks of the railroad company at other than an established public crossing; and any other work that may affect railroad operations or property.

Contact the FEC Signal Office at 904-279-3182 at least 30 days prior to any traffic signal work within 500 feet of a signalized, at-grade, rail-highway crossing.

**7-11.4.2 Contractor's Responsibilities:** Comply with requirements deemed necessary by the railroad company's authorized representative to safeguard the railroad's property and operations. Do not perform temporary lane closures, lane shifts or detour routes within the railroad company right-of-way without railroad approval.

The Contractor is responsible for all damages, delays, or injuries and all suits, actions, or claims brought on account of damages or injuries resulting from the Contractor's operations within or adjacent to railroad company right-of-way.

**7-11.4.2.1 CSXT:** Comply with the Construction Submission Criteria of the CSXT Public Project Information document and Construction Requirements sections of the CSXT Pipeline and Wireline Design and Construction Specifications prior to beginning work. These documents are available at the following URL: <http://www.fdot.gov/programmanagement/Implemented/URLinSpecs/CSXT.shtm>.

Perform no work within the limits of the railroad right-of-way on CSXT holidays. CSXT holidays are New Year's Day, President's Day, Good Friday, Memorial Day, Independence Day, Labor Day, Thanksgiving Day and the following Friday, Christmas Eve, Christmas Day, and New Year's Eve. Holidays falling on Saturday are observed on Friday and those falling on Sunday are observed on Monday.

**7-11.4.2.2 NS:** Comply with the NS Special Provisions for Protection of Railway Interests (Appendix E) and the Construction Requirements (Appendix 4.3) of the NS Public Projects Manual document prior to beginning and during all work. These documents are available at the following URL: [http://www.nscorp.com/content/dam/nscorp/ship/shipping-tools/Public\\_Projects\\_Manual.pdf](http://www.nscorp.com/content/dam/nscorp/ship/shipping-tools/Public_Projects_Manual.pdf).

**7-11.4.2.3 FEC:** Complete the On-Track Contractor Roadway Worker Training Course for FEC Railway. Contact FEC Railway at 1-800-342-1131 for training information.

Costs incurred by the railroad for Contractor caused delays that adversely impact railway operations will be forwarded to the Contractor for payment. If the Contractor fails to pay said costs, the Department will deduct the amount from payments to be made to the Contractor.

**7-11.4.3 Watchman or Flagging Services:**

**7-11.4.3.1 CSXT, NS, and FEC:**

**7-11.4.3.1.1 General:** The railroad company will furnish protective services (i.e., watchman or flagging services) to ensure the safety of railroad operations during certain periods of the project. The Department will reimburse the

railroad company for the cost thereof. Schedule work that affects railroad operations so as to minimize the need for protective services by the railroad company.

**7-11.4.3.1.2 CSXT:** Submit schedules and schedule changes to the Engineer so the Department can coordinate the scheduling of flagging resources. Projects with less than 20 consecutive days of flagging services require a CSXT short-term flagger and 45 days written advance notice. Submit the 45 days written advance notice to the Engineer. Projects with 20 or more consecutive days of flagging services require a CSXT long term flagger. The Department will submit the 6 months written advance notice to CSXT.

**7-11.4.3.1.3 NS:** Submit schedules and schedule changes to the Engineer so the Department can coordinate the scheduling of flagging resources. Projects with less than 20 consecutive days of flagging services require a NS short-term flagger and 45 days written advance notice. Submit the 45 days written advance notice to the Engineer. Projects with 20 or more consecutive days of flagging services require a NS long term flagger. The Department will submit the 6 months written advance notice to NS.

**7-11.4.3.1.4 FEC:** Contact FEC Railway at 1-800-342-1131, ext. 2377, to request signal locates and railroad watchmen or flagging services at least 72 hours prior to railroad right-of-way encroachments. When requesting railroad watchman or flagging services, identify the work as a Florida Department of Transportation project.

**7-11.4.3.2 Department-Owned Rail Corridors:** The Department will furnish protective services (i.e., watchman or flagging services) to ensure the safety of railroad operations during certain periods of the project.

For projects involving the South Florida Rail Corridor (SFRC), contact the South Florida Regional Transportation Authority (SFRTA) at 954-788-1788 at least 30 days prior to rail corridor right-of-way encroachments to coordinate the scheduling of flagging resources.

For projects involving the Central Florida Rail Corridor (CFRC), submit written advance notice to the Engineer at least 30 days prior to rail corridor right-of-way encroachments so the Department can coordinate the scheduling of flagging resources.

## **UTILITY WORK.**

**(REV 2-10-94) (7-17)**

SUBARTICLE 7-11.5.3 is expanded by the following:

For this project, no utility work involving facilities owned by other agencies is anticipated.

**LEGAL REQUIREMENTS AND RESPONSIBILITY TO THE PUBLIC –  
CONTRACTOR’S RESPONSIBILITY FOR WORK.  
(REV 5-27-15) (7-17)**

Article 7-14 is deleted and the following substituted:

**7-14 Contractor’s Responsibility for Work.**

Until the Department’s acceptance of the work, take charge and custody of the work, and take every necessary precaution against injury or damage to the work by the action of the elements or from any other cause whatsoever, arising either from the execution or from the nonexecution of the work. Rebuild, repair, restore, and make good, without additional expense to the Department, all injury or damage to any portion of the work occasioned by any of the above causes before its completion and acceptance, except that in case of extensive or catastrophic damage, the Department may, at its discretion, reimburse the Contractor for the repair of such damage due to unforeseeable causes beyond the control of and without the fault or negligence of the Contractor, including but not restricted to Acts of God, of the public enemy, or of governmental authorities.

**EQUAL EMPLOYMENT OPPORTUNITY REQUIREMENTS.  
(REV 4-25-02) (FA 7-17-02) (7-17)**

SECTION 7 is expanded by the following:

**7-27 Equal Employment Opportunity Requirements.**

**7-27.1 Equal Employment Opportunity Policy:** Accept as the operating policy, the following statement which is designed to further the provision of equal employment opportunity to all persons without regard to their age, race, color, religion, national origin, sex, or disability and to promote the full realization of equal employment opportunity through a positive continuing program:

“It is the policy of this Company to assure that applicants are employed, and that employees are treated during employment, without regard to their age, race, religion, color, national origin, sex, or disability. Such action must include: employment, upgrading, demotion, or transfer; recruitment or recruitment advertising; layoff or termination; rates of pay or other forms of compensation; and selection for training, including apprenticeship, preapprenticeship, and/or on-the-job training.”

**7-27.2 Equal Employment Opportunity Officer:** Designate and make known to the Department’s contracting officers an equal employment opportunity officer (hereinafter referred to as the EEO Officer) who must be capable of effectively administering and promoting an active Contractor program employment opportunity and who must be assigned adequate authority and responsibility to do so.

**7-27.3 Dissemination of Policy:** All members of the Contractor’s staff who are authorized to hire, supervise, promote, and discharge employees, or who recommend such action, or who are substantially involved in such action, will be made fully cognizant of, and will implement, the Contractor’s equal employment opportunity policy and contractual responsibilities.

**7-27.4 Recruitment:** When advertising for employees, include in all advertisements for employees the notation “An Equal Opportunity Employer”.

**7-27.5 Personnel Actions:** Establish and administer wages, working conditions, employee benefits, and personnel actions of every type, including hiring, upgrading, promotion, transfer, demotion, layoff, and termination without regard to age, race, color, religion, national origin, sex, or disability.

Follow the following procedures:

(1) Conduct periodic inspections of project sites to insure that working conditions and employee facilities do not indicate discriminatory treatment of project site personnel.

(2) Periodically evaluate the spread of wages paid with each classification to determine any evidence of discriminatory wage practices.

(3) Periodically review selected personnel actions in depth to determine whether there is evidence of discrimination. Where evidence is found, promptly take corrective action. If the review indicates that the discrimination may extend beyond the actions reviewed, such corrective action must include all affected persons.

(4) Investigate all complaints of alleged discrimination made in connection with obligations under this Contract, attempt to resolve such complaints, and take appropriate corrective action. If the investigation indicates that the discrimination may affect persons other than the complainant, such corrective action must include such other persons. Upon completion of each investigation inform every complainant of all of the avenues of appeal.

**7-27.6 Subcontracting:** Use the best efforts to ensure subcontractor compliance with their equal employment opportunity policy.

**7-27.7 Records and Reports:** Keep such records as are necessary to determine compliance with the equal employment opportunity obligations. The records kept will be designed to indicate the following:

(1) The number of minority and nonminority group members employed in each work classification on the project.

(2) The progress and efforts being made in cooperation with unions to increase minority group employment opportunities (applicable only to Contractors who rely in whole or in part on unions as a source of their work force).

(3) The progress and efforts being made in locating, hiring, training, qualifying, and upgrading minority group employees as deemed appropriate to comply with their Equal Employment Opportunity Policy.

(4) The progress and efforts being made in securing the services of minority group subcontractors or subcontractors with meaningful minority group representation among their employees as deemed appropriate to comply with their Equal Employment Opportunity Policy.

All such records must be retained for a period of three years following completion of the contract work and be available at reasonable times and places for inspection by authorized representatives to the Department and the Federal Highway Administration.

Upon request, submit to the Department a report of the number of minority and nonminority group employees currently engaged in each work classification

required by the Contract work.

## **LEGAL REQUIREMENTS AND RESPONSIBILITY TO THE PUBLIC – E-VERIFY.**

**(REV 6-13-11) (FA 6-16-11) (7-17)**

SECTION 7 is expanded by the following new Article:

### **7-29 E-Verify.**

The Contractor shall utilize the U.S. Department of Homeland Security's E-Verify system to verify the employment eligibility of all new employees hired by the Contractor during the term of the Contract and shall expressly require any subcontractors performing work or providing services pursuant to the Contract to likewise utilize the U.S. Department of Homeland Security's E-Verify system to verify the employment eligibility of all new employees hired by the subcontractor during the Contract term.

## **PROSECUTION AND PROGRESS – SUBLETTING OR ASSIGNING OF CONTRACTS.**

**(REV. 10-8-15) (7-17)**

ARTICLE 8-1 is deleted and the following substituted:

### **8-1 Subletting or Assigning of Contracts.**

Do not sell, transfer, assign or otherwise dispose of the Contract or Contracts or any portion thereof, or of any right, title, or interest therein, without written consent of the Department. If the Contractor chooses to sublet any portion of the Contract, the Contractor must provide a written request to sublet work on the Certification of Sublet Work form developed by the Department for this purpose. With the Engineer's acceptance of the request, the Contractor may sublet a portion of the work. The Certification of Sublet Work request will be deemed acceptable to the Department, for purposes of the Department's consent, unless the Engineer notifies the Contractor within 5 business days of receipt of the Certification of Sublet Work that the Department is not consenting to the request.

Include in the total Contract amount the cost of materials and manufactured component products, and their transportation to the project site. For the purpose of meeting this requirement, the Department will not consider off-site commercial production of materials and manufactured component products that the Contractor purchases, or their transportation to the project, as subcontracted work.

Execute all agreements to sublet work in writing and include all pertinent provisions, specifications and requirements of the Contract. Upon request, furnish the Department with a copy of the subcontract. The subletting of work does not relieve the Contractor or the surety of their respective responsibilities and liabilities under the Contract and Contract Bond.

The Department recognizes a subcontractor only in the capacity of an employee or agent of the Contractor, and the Engineer may require the Contractor to remove the subcontractor as in the case of an employee.

**PROSECUTION AND PROGRESS.**

**(REV. 10-8-15) (7-17)**

ARTICLE 8-2 is deleted and replaced by the following:

**8-2 Work Performed by Equipment Rental Agreement.**

Rental agreements will not be considered subcontracts.

SUBARTICLE 8-3.2 is deleted.

SUBARTICLE 8-3.3, the last sentence has been deleted and the following substituted:

The Department will issue the Notice to Proceed within 20 days after the Department's execution of the Contract.

SUBARTICLE 8-3.5 is deleted and the following substituted:

**8-3.5 Preconstruction Conference:** Immediately after executing the Contract but before the Contractor begins work, the Engineer will call a pre-work conference at a location the Engineer designates to go over the work required by the Contract. Attend this meeting, along with the Department and any utility companies that will be involved with the work.

**PROSECUTION AND PROGRESS –DISPUTES REVIEW BOARD.**

**(REV 8-3-10) (7-17)**

ARTICLE 8-3 is expanded by the following new Subarticle:

**8-3.7 Maintenance Disputes Review Board:** For this Maintenance Contract, a Maintenance Disputes Review Board will be available to assist in the resolution of disputes and claims arising out of the work on the Contract.

**8-3.7.1 Purpose:** The Board will provide special expertise to assist in and facilitate the timely and equitable resolution of disputes, claims, and controversies

between the Department and the Contractor in an effort to avoid contract delay and future claims.

It is not intended that the Department or the Contractor default on their normal responsibility to cooperatively and fairly settle their differences by indiscriminately assigning them to the Board. It is intended that the Board encourage the Department and Contractor to resolve potential disputes without resorting to this alternative resolution procedure.

The Board will be used when normal Department-Contractor dispute resolution is unsuccessful. Either the Department or the Contractor may refer a dispute to the Board. Referral to the Board should be initiated as soon as it appears that the normal dispute resolution effort is not succeeding. It is a condition of this Contract that the parties shall use the Maintenance Dispute Review Board. The Department and the Contractor agree that the submission of any unresolved dispute or claim to the Board is a condition precedent to the Department or the Contractor having the right to proceed to arbitration or litigation of such unresolved dispute or claim. The Department's Claim Review Committee will not entertain any issues on this project.

The recommendations of the Board will not be binding on either the Department or the Contractor.

The Board will fairly and impartially and without regard to how or by whom they may have been appointed, consider disputes referred to it and will provide written recommendations to the Department and Contractor to assist in the resolution of these disputes.

**8-3.7.2 Continuance of Work During Dispute:** During the course of the Maintenance Disputes Review Board process, the Contractor will continue with the work as directed by the Engineer in a diligent manner and without delay or otherwise conform to the Engineer's decision or order, and will be governed by all applicable provisions of the Contract. Throughout any protested work, the Contractor will keep complete records of extra costs and time incurred. The Contractor will permit the Engineer and Board access to these and any other records needed for evaluating the dispute.

**8-3.7.3 Membership:** The Maintenance Disputes Review Board will consist of the same members as established for the "Regional Disputes Review Board", pre-selected by the Department and the President of the Florida Transportation Builders' Association (FTBA), and posted on the Department's Website.

If during the life of the contract, a Board member has a discussion regarding employment or enter into any agreement for employment after completion of the contract with the Department, the Contractor or any subcontractor or supplier on the project, he/she shall immediately disclose this to the Contractor and the Department and shall be disqualified from serving on the Board.

Once established, the Board will remain active and in full force and effect. If, after the Department has made final acceptance of the project, there are unresolved disputes and claims remaining, the Maintenance Disputes Review Board shall remain active and in full force and effect until the project is otherwise administratively closed by the Department following final payment so that the Board may continue in operation until all unresolved disputes and claims are resolved.

**8-3.7.4 Procedure and Schedules for Disputes Resolution:** Disputes will be considered as quickly as possible, taking into consideration the particular



circumstances and the time required to prepare detailed documentation. Steps may be omitted as agreed by the Department and the Contractor and the time periods stated below may be shortened in order to hasten resolution.

a. If the Contractor objects to any decision, action or order of the Engineer, the Contractor may file a written protest with the Engineer, stating clearly and in detail the basis for the objection, within 15 days after the event.

b. The Engineer will consider the written protest and make his decision on the basis of the pertinent contract provisions, together with the facts and circumstances involved in the dispute. The Engineer's decision will be furnished in writing to the Contractor within 15 days after receipt of the Contractor's written protest.

c. This decision will be final and conclusive on the subject, unless a written appeal to the Engineer is filed by the Contractor within 15 days of receiving the decision. Should the Contractor preserve its protest of the Engineer's decision, the matter can be referred to the Board by either the Department or the Contractor.

d. Upon receipt by the Board of a written duly preserved protest of a dispute, either from the Department or the Contractor, it will first be decided when to conduct the hearing.

e. Either party furnishing any written evidence or documentation to the Board will furnish copies of such information to the other party a minimum of 15 days prior to the date the Board sets to convene the hearing for the dispute. If the Board requests any additional documentation or evidence prior to, during, or after the hearing, the Department and/or Contractor will provide the requested information to the Board and to the other party.

f. The Contractor and the Department will each be afforded an opportunity to be heard by the Board and to offer evidence. Neither the Department nor the Contractor may present information at the hearing that was not previously distributed to both the Board and the other party.

g. The Board's recommendations for resolution of the dispute will be given in writing to both the Department and the Contractor, within 15 days of completion of the hearings. In cases of extreme complexity, both parties may agree to allow additional time for the Board to formulate its recommendations. The Board will focus its attention in the written report to matters of entitlement and allow the parties to determine the monetary damages. If both parties' request and sufficient documentation is available, the Board may make a recommendation of monetary damages.

h. Within 15 days of receiving the Board's recommendations, both the Department and the Contractor will respond to the other and to the Board in writing, signifying either acceptance or rejection of the Board's recommendations. The failure of either party to respond within the 15 day period will be deemed an acceptance of the Board's recommendations by that party. If the Department and the Contractor are able to resolve the dispute with or without the aid of the Board's recommendations, the Department will promptly process any required Contract changes.

i. Should the dispute remain unresolved, either party may seek reconsideration of the decision by the Board only when there is new evidence to present. No provisions in this Specification will abrogate the Contractor's responsibility for preserving a claim filed in accordance with 5-12.

Although both the Department and the Contractor should place great weight on the Board's recommendation, it is not binding. If the Board's recommendations do not resolve the dispute, all records and written recommendations of the Board will be admissible as evidence in any subsequent dispute resolution procedures.

**8-3.7.5 Contractor Responsibility:** The Contractor shall furnish to each Board member a set of all pertinent documents which are or may become necessary for the Board, except documents furnished by the Department, to perform their function. Pertinent documents are any drawings or sketches, calculations, procedures, schedules, estimates, or other documents which are used in the performance of the work or in justifying or substantiating the Contractor's position. A copy of such pertinent documents must also be furnished to the Department.

Except for its participation in the Board's activities as provided in the maintenance Contract and in this Agreement, the Contractor will not solicit advice or consultation from the Board or any of its members on matters dealing in any way with the project, the conduct of the work or resolution of problems.

**8-3.7.6 Department Responsibilities:** Except for its participation in the Board's activities as provided in the maintenance Contract and in this Agreement, the Department will not solicit advice or consultation from the Board or any of its members on matters dealing in any way with the project, the conduct of the work or resolution of problems.

The Department shall furnish the following services and items:

a. Contract Related Documents: The Department shall furnish each Board member a copy of all Contract Documents, supplemental agreements, written instructions issued by the Department to the Contractor, or other documents pertinent to the performance of the Contract and necessary for the Board to perform their function. A copy of such pertinent documents must also be furnished to the Contractor.

b. Coordination and Services: The Department, in cooperation with the Contractor, will coordinate the operations of the Board. The Department, through the Engineer, will arrange or provide conference facilities at or near the Contract site and provide secretarial and copying services.

**8-3.7.7 Payment:** A per hearing cost of \$8,000.00 has been established by the Department to provide compensation for all members of the Maintenance Disputes Review Board. For each hearing, the Contractor shall compensate the Maintenance Disputes Review Board chairman the sum of \$3,000.00, and the remaining two members will receive \$2,500.00 each. Such payment will be full compensation to the Board member for salary and all travel expenses (air fare, rental or personal automobile, motel room, meals, etc.) related to membership on the Board. The Department will reimburse the Contractor for Board expenses incurred if the findings of the Board are in favor of the Contractor. If the findings are in favor of the Department the Department will not reimburse the Contractor for Board expenses incurred. If the Board rules on multiple issues during a single hearing, Department reimbursement to the Contractor is based on ratio of findings (e.g., if Board hears four issues, regardless of importance or value, and rules favorably for the Contractor on three of them, the Department reimburses Contractor for 75% of Board costs).

The Department will pay all other non-salary and non-travel expenses related to operation of the Board. The Department will prepare and mail minutes and progress reports, will provide administrative services, such as conference facilities and secretarial services, and will bear the cost of these services. If the Board desires special services, such as legal consultation, accounting, data research, and the like, both parties must agree, and the costs will be shared by them as mutually agreed. Payment for non-salary and non-travel expenses and the Department's share of special services shall be made by the Engineer in accordance with Department policy outside of this Contract.

## **PROSECUTION AND PROGRESS.**

**(REV 8-1-00) (7-17)**

SUBARTICLE 8-4.1. The fifth paragraph is deleted.

SUBARTICLE 8-7.3.1 is deleted and the following substituted:

**8-7.3.1 Increased Work:** The Department may grant an extension of Contract Time when it increases the Contract amount due to adding new work or providing for unforeseen work. The Department will base the consideration for granting an extension of Contract Time on the extent that the time normally required to complete the additional designated work delays the Contract completion schedule.

## **PROSECUTION AND PROGRESS - EQUIPMENT.**

**(REV 3-2-17) (7-17)**

ARTICLE 8-4 is expanded by the addition of the following new Subarticle:

**8-4.10 Equipment:** Equip vehicles and mobile equipment used on the project with a minimum of one class 2 amber or white flashing light that meets the Society of Automotive Engineers recommended practice SAE J845 and SAE J1318. The Engineer may require a white flashing light meeting the above requirements when conditions reduce the effectiveness of amber light (i.e., at night under high intensity discharge lights such as sodium vapor).

Ensure all equipment safety devices recommended by the manufacturer are installed and properly maintained.

Park vehicles and equipment not in use or left on the right-of-way overnight as close as possible to the right-of-way line and always outside of the applicable clear zone. Conduct service and supply operations as close to the right-of-way line as possible. Do not park equipment in the median, regardless of the width of the median, unless movement from the work area is determined by the Engineer to be prohibitive.

SUBARTICLE 8-5 is expanded by the following:

All persons employed by the Contractor or Subcontractors working within the Department's right-of-way must have Tier 1 Illicit Discharge Detection and Elimination (IDDE) training. The computer based training is provided by video on the following web page: <http://wbt.dot.state.fl.us/ois/EnvironmentalManagementOffice/index.html>.

Provide a list of persons trained prior to submittal of the first invoice. Provide an updated list of new Contractor/Subcontractor employees annually thereafter.

**PROSECUTION AND PROGRESS – CONTRACT TIME EXTENSIONS.  
(REV 2-15-17) (7-17)**

SUBARTICLE 8-7.3.2 is deleted and the following substituted:

**8-7.3.2 Contract Time Extensions:** The Department may grant an extension of Contract Time when a controlling item of work is delayed by factors not reasonably anticipated or foreseeable at the time of bid. The Department may allow such extension of time only for delays occurring during the Contract Time period or authorized extensions of the Contract Time period. When failure by the Department to fulfill an obligation under the Contract results in delays to the controlling items of work, the Department will consider such delays as a basis for granting a time extension to the Contract.

Whenever the Engineer suspends the Contractor's operations, as provided in 8-6, for reasons other than the fault of the Contractor, the Engineer will grant a time extension for any delay to a controlling item of work due to such suspension. The Department will not grant time extensions to the Contract for delays due to the fault or negligence of the Contractor.

The Department does not include an allowance for delays caused by the effects of inclement weather or suspension of Contractor's operations as defined in 8-6.4, in establishing Contract Time. The Engineer will continually monitor the effects of weather and, when found justified, grant time extensions on either a bimonthly or monthly basis. The Engineer will not require the Contractor to submit a request for additional time due to the effects of weather.

The Department will grant time extensions, on a day for day basis, for delays caused by the effects of rains or other inclement weather conditions, related adverse soil conditions or suspension of operations as defined in 8-6.4 that prevent the Contractor from productively performing controlling items of work resulting in:

(1) The Contractor being unable to work at least 50% of the normal work day on pre-determined controlling work items; or

(2) The Contractor must make major repairs to work damaged by weather, provided that the damage is not attributable to the Contractor's failure to perform or neglect; and provided that the Contractor was unable to work at least 50% of the normal workday on pre-determined controlling work items.

No additional compensation will be made for delays caused by the effects of inclement weather.

The Department will consider the delays in delivery of materials or component equipment that affect progress on a controlling item of work as a basis for granting a time extension if such delays are beyond the control of the Contractor or supplier. Such delays may include an area-wide shortage, an industry-wide strike, or a natural disaster that affects all feasible sources of supply. In such cases, the Contractor shall furnish substantiating letters from a representative number of manufacturers of such materials or equipment clearly confirming that the delays in delivery were the result of an area-wide shortage, an industry-wide strike, etc. No additional compensation will be made for delays caused by delivery of materials or component equipment.

The Department will not consider requests for time extension due to delay in the delivery of custom manufactured equipment such as traffic signal equipment, highway lighting equipment, etc., unless the Contractor furnishes documentation that he placed the order for such equipment in a timely manner, the delay was caused by factors beyond the manufacturer's control, and the lack of such equipment caused a delay in progress on a controlling item of work. No additional compensation will be paid for delays caused by delivery of custom manufactured equipment.

The Department will consider the affect of utility relocation and adjustment work on job progress as the basis for granting a time extension only if all the following criteria are met:

(1) Delays are the result of either utility work that was not detailed in the plans, or utility work that was detailed in the plans but was not accomplished in reasonably close accordance with the schedule included in the Contract Documents.

(2) Utility work actually affected progress toward completion of controlling work items.

(3) The Contractor took all reasonable measures to minimize the effect of utility work on job progress, including cooperative scheduling of the Contractor's operations with the scheduled utility work at the preconstruction conference and providing adequate advance notification to utility companies as to the dates to coordinate their operations with the Contractor's operations to avoid delays.

As a condition precedent to an extension of Contract Time the Contractor must submit to the Engineer:

A preliminary request for an extension of Contract Time must be made in writing to the Engineer within ten calendar days after the commencement of a delay to a controlling item of work. If the Contractor fails to submit this required preliminary request for an extension of Contract Time, the Contractor fully, completely, absolutely and irrevocably waives any entitlement to an extension of Contract Time for that delay. In the case of a continuing delay only a single preliminary request for an extension of Contract Time will be required. Each such preliminary request for an extension of Contract Time shall include as a minimum the commencement date of the delay, the cause of the delay, and the controlling item of work affected by the delay.

Furthermore, the Contractor must submit to the Engineer a request for a Contract Time extension in writing within 30 days after the elimination of the delay to the controlling item of work identified in the preliminary request for an

extension of Contract Time. Each request for a Contract Time extension shall include as a minimum all documentation that the Contractor wishes the Department to consider related to the delay, and the exact number of days requested to be added to Contract Time. If the Contractor contends that the delay is compensable, then the Contractor shall also be required to submit with the request for a Contract Time extension a detailed cost analysis of the requested additional compensation. If the Contractor fails to submit this required request for a Contract Time extension, with or without a detailed cost analysis, depriving the Engineer of the timely opportunity to verify the delay and the costs of the delay, the Contractor waives any entitlement to an extension of Contract Time or additional compensation for the delay.

Upon timely receipt of the preliminary request of Contract Time from the Contractor, the Engineer will investigate the conditions, and if it is determined that a controlling item of work is being delayed for reasons beyond the control of the Contractor the Engineer will take appropriate action to mitigate the delay and the costs of the delay. Upon timely receipt of the request for a Contract Time extension the Engineer will further investigate the conditions, and if it is determined that there was an increase in the time or the cost of performance of the controlling item of work beyond the control of the Contractor, then an adjustment of Contract Time will be made, and a monetary adjustment will be made, excluding loss of anticipated profits, and the Contract will be modified in writing accordingly.

ARTICLE 8-8 is deleted and the following substituted:

**8-8 Contractor Non-Responsibility.**

Section 337.16(2) of the Florida Statutes and Rule 14-22, Florida Administrative Code (FAC), establish certain requirements for Contractors bidding on or any Maintenance Contracts, and authorize ineligibility to bid due to Contractor non-responsibility.

The Department will review and rate the performance of each Contractor using the Contractor Field Performance Report. The Contractor will receive written notification of the Field Performance Report and will be given an opportunity to resolve disputes concerning the rating.

SUBARTICLE 8-9.1 is deleted and the following substituted:

**8-9.1 Determination of Default:** The following acts or omissions constitute acts of default and, except as to subparagraphs (i and k), the Department will give notice, in writing, to the Contractor and his surety for any delay, neglect or default, if the Contractor:

(a) fails to begin the work under the Contract within the time specified in the Notice to Proceed;

(b) fails to perform the work with sufficient workmen and equipment or with sufficient materials to ensure prompt completion of the Contract;

(c) performs the work unsuitably, or neglects or refuses to remove materials or to perform anew such work that the Engineer rejects as unacceptable and unsuitable;

(d) discontinues the prosecution of the work, or fails to resume discontinued work within a reasonable time after the Engineer notifies the Contractor to do so;

(e) becomes insolvent or is declared bankrupt, or files for reorganization under the bankruptcy code, or commits any act of bankruptcy or insolvency, either voluntarily or involuntarily;

(f) allows any final judgment to stand against him unsatisfied for a period of ten calendar days;

(g) makes an assignment for the benefit of creditors;

(h) fails to comply with Contract requirements regarding minimum wage payments or EEO requirements;

(i) fails to comply with the Engineer's written suspension of work order within the time allowed for compliance and which time is stated in that suspension of work order; or

(j) for any other cause whatsoever, fails to carry on the work in an acceptable manner, or if the surety executing the bond, for any reasonable cause, becomes unsatisfactory in the opinion of the Department.

(k) fails to comply with 3-9.

(l) fails to provide all required insurance and to keep said insurance in force during the duration of the Contract.

For a notice based upon reasons stated in subparagraphs (a) through (h) and (j): if the Contractor, within a period of time specified by the Department after receiving the notice described above, fails to correct the conditions of which complaint is made, the Department will, upon written certificate from the Engineer of the fact of such delay, neglect, or default and the Contractor's failure to correct such conditions, have full power and authority, without violating the Contract, to take the prosecution of the work out of the hands of the Contractor and to declare the Contractor in default.

If the Contractor, after having received a prior notice described above for any reason stated in subparagraph (b), (c), (d), (e), (f) or (h), commits a second or subsequent act of default for any reason covered by the same subparagraph (b), (c), (d), (e), (f) or (h) as stated in the prior notice, and regardless whether the specific reason is the same, then, regardless of whether the Contractor has cured the deficiency stated in that prior notice, the Department will, upon written certificate from the Engineer of the fact of such delay, neglect or default and the Contractor's failure to correct such conditions, have full power and authority, without any prior written notice to the Contractor and without violating the Contract, to take the prosecution of the work out of the hands of the Contractor and to declare the Contractor in default.

Regarding subparagraph (i), if the Contractor fails to comply with the Engineer's written suspension of work order within the time allowed for compliance and which time is stated in that suspension of work order, the Department will, upon written certificate from the Engineer of the fact of such delay and the Contractor's failure to correct that condition, have full power and authority, without violating the Contract, to

immediately take the prosecution of the work out of the hands of the Contractor and to declare the Contractor in default.

Regarding subparagraph (k), if the Contractor fails to comply with 3-9, the Department will have full power and authority, without violating the Contract, to immediately take the prosecution of the work out of the hands of the Contractor and to declare the Contractor in default.

The Department has no liability for anticipated profits for unfinished work on a Contract that the Department has determined to be in default.

Notwithstanding the above, the Department shall have the right to declare the Contractor (or its "affiliate") in default and immediately terminate this Contract, without any prior notice to the Contractor, in the event the Contractor (or its "affiliate") is at any time "convicted" of a "contract crime," as these terms are defined in Section 337.165(1), Florida Statutes. The Department's right to default the Contractor (or its "affiliate") for "conviction" of a "contract crime" shall extend to and is expressly applicable to any and all Department Contracts that were either advertised for bid; for which requests for proposals or letters of interest were requested; for which an intent to award was posted or otherwise issued; or for which a Contract was entered into, after the date that the underlying or related criminal indictment, criminal information or other criminal charge was filed against the Contractor (or its "affiliate") that resulted in the "conviction." In the event the Department terminates this Contract for this reason, the Contractor shall hereby forfeit any claims for additional compensation, extra time, or anticipated profits. The Contractor shall only be paid for any completed work up to the date of termination. Further, the Contractor shall be liable for any and all additional costs and expenses the Department incurs in completing the Contract work after such termination.

SUBARTICLE 8-9.3 is deleted and the following substituted:

**8-9.3 Completion of Work by Department:** Upon declaration of default, the Department will have full authority to appropriate or use any or all suitable and acceptable materials and equipment on the site and may enter into an agreement with others to complete the work under the Contract, or may use other methods to complete the work in an acceptable manner. The Department will charge all costs that the Department incurs because of the Contractor's default, including the costs of completing the work under the Contract, against the Contractor. If the Department incurs such costs in an amount that exceeds the sum that would have been payable under the Contract, then the Contractor and the surety shall be liable and shall pay the Department the amount of the excess.

If, after the period of time specified by the Department and prior to any action by the Department to otherwise complete the work under the Contract, the Contractor establishes his intent to prosecute the work in accordance with the Department's requirements, then the Department may allow the Contractor to resume the work, in which case the Department will deduct from any monies due or that may become due under the Contract, any costs to the Department incurred by the delay, or from any reason attributable to the delay.



**DAMAGE RECOVERY.**

**(REV 2-4-04) (7-17)**

SECTION 8 is expanded by the following:

A damage recovery/user cost will be assessed against the Contractor if all lanes are not open to traffic during the times as shown in the Traffic Control Plans. Costs will be assessed beginning at the appropriate time as shown in the Traffic Control Plans and continue until all lanes are open as recorded by the Engineer. This assessment will be in the following amounts:

SR 436 Section 77080  
First 30 minutes and under: \$1,432.00  
Each additional 30 minute period or portion thereof: \$1,217.00  
Such costs will not exceed \$17,179.00 over a 24 hour period.

SR 426 Section 75040  
First 30 minutes and under: \$ 1,590.00  
Each additional 30 minute period or portion thereof: \$ 1,875.00  
Such costs will not exceed \$ 22,500.00 over a 24 hour period.

At the discretion of the Engineer, damage recovery/user cost will not be assessed for failure to open traffic lanes if such cause is beyond the control of the Contractor, i.e., catastrophic events, accidents not related or caused by the Contractor's operations.

The Department will have the right to apply as payment on such damages any money which is due to the Contractor by the Department.

**MEASUREMENT AND PAYMENT – SCOPE OF PAYMENTS.**

**(REV 8-12-16) (7-17)**

SUBARTICLE 9-2.1 is expanded as follows:

Request payment for work completed and accepted by the Department by submitting an invoice using the pay items and unit prices contained in the Contract. Include the Contract Number, the Financial Project Number, the Invoice Number, the Invoice Date and the period that the invoice represents. If required by the Engineer, furnish photos of the completed work at each location with the invoice. Submit the invoice no more often than once every 28 days to the Engineer in charge of the project. Upon receipt and approval, payment will be made less an amount retained or withheld in the Contract.

For Lump Sum contracts, within 21 calendar days after contract award or at the pre-work meeting, whichever is earlier, prepare and submit to the Engineer a

schedule of values. With the Engineer's approval, the schedule of values will be the basis for determining monthly payments.

SUBARTICLES 9-2.1.1 and 9-2.1.2 are deleted.

SUBARTICLE 9-3.2 is deleted.

SUBARTICLE 9-3.3.1 is deleted and the following substituted:

**9-3.3.1 Error in Lump Sum Quantity:** Where the Department designates the pay quantity for an item to be a lump sum and the plans show an estimated quantity, the Department will adjust the lump sum compensation only in the event that either the Contractor submits satisfactory evidence or the Department determines and furnishes satisfactory evidence that the lump sum quantity shown is in substantial error. The term "substantial error" is defined as the smaller of (a) or (b) below:

(a) a difference between the original plan quantity and final quantity of more than 5%,

(b) a change in quantity which causes a change in the amount payable of more than \$5,000.

SUBARTICLE 9-5.1 is deleted and the following substituted:

**9-5.1 General:** If the Contract Time extends over a period in excess of 45 calendar days, the Contractor may claim partial payment for work completed and accepted by the Department by submitting an invoice. The actual reimbursement to the contractor will be based on:

1. the items shown in the schedule of values completed for the Lump Sum contract, or

2. the pay items and the unit prices contained in the Contract Document completed, and accepted by the Engineer in charge .

Contract amount is defined as the original contract amount adjusted by approved supplemental agreements.

Retainage will be determined for each project on multiple project Contracts. The Department will not accept Securities, Certificates of Deposit or letters of credit as a replacement for retainage. Amounts withheld will not be released until payment of the final estimate.

An amount may be retained from a Contractor's payment until final acceptance of materials or work at the end of a burn-in or establishment period. The amount retained will be determined in accordance with the following schedule:

Percentage Contract Amount Completed	Amount Retained
0 to 75	None
75 to 100	10 % of value of work completed exceeding 75% of Contract Amount.

The Engineer will make payments based upon invoices submitted by the Contractor in accordance with 9-2.1.

SUBARTICLE 9-5.5 is deleted.

ARTICLE 9-8 is deleted and the following substituted:

**9-8 Acceptance and Final Payment.**

Submit a completed Contractor's Affidavit and Surety Consent (Form 21-A) (Department Form Number 700-050-21) to the Department within 90 days of submittal of the final invoice. Failure to submit this form may result in a determination of Contractor Non-Responsibility under the provisions of 14-22.0141, F.A.C., and the Contractor will be prohibited from bidding, subcontracting, or acting as a material supplier on any Department contracts.

ARTICLE 9-9 is expanded by the following:

Section 215.422(5), Florida Statutes, requires the Department to include a statement of vendor (Contractor) rights. Contractors are hereby advised of the following:

Contractors providing goods and services to an agency should be aware of the following time frames: Upon receipt, an agency has five working days to inspect and approve the goods and services, unless the bid specifications, purchase order or Contract specifies otherwise. An agency has 20 days to deliver a request for payment (voucher) to the Department of Financial Services. The 20 days are measured from the latter of the date the invoice is received or the goods or services are received, inspected and approved, by the Department of Transportation.

If a payment is not made within 40 days, a separate interest penalty at the rate established pursuant to Section 55.03(1), Florida Statutes will be due and payable in addition to the invoice amount, to the Contractor. The interest penalty provision applies after a 35-day time period to health care providers, as defined by rule. Interest penalties of less than one dollar will not be enforced unless the Contractor requests payment. Invoices which have to be returned to a Contractor because of Contractor preparation errors will result in a delay in the payment. The invoice payment requirements do not start until a properly completed invoice is provided to the Department.

A Vendor Ombudsman has been established within the Department of Financial Services. The duties of this individual include acting as an advocate for Contractors who may be experiencing problems in obtaining timely payment(s) from a state agency. The Vendor Ombudsman may be contacted by calling the Bureau of Accounting at (850) 413-5516.

**CONSTRUCTION EQUIPMENT - GENERAL REQUIREMENTS.**  
**(REV 1-28-15) (7-17)**

SUBARTICLE 100-1 is expanded by the following:

Clearly and legibly identify the owner of all equipment on the Department's right-of-way.

**MAINTENANCE OF TRAFFIC.**  
**(REV 2-27-17)**

SUBARTICLE 102-5.4 is deleted and the following substituted:

**102-5.4 Crossings and Intersections:** Provide and maintain adequate accommodations for intersecting and crossing traffic. Do not block or unduly restrict any median opening, road or street crossing the project unless approved by the Engineer. Maintain all existing actuated or traffic responsive mode signal operations for main and side street movements for the duration of the work. Restore any loss of detection within 12 hours. Use only detection technology listed on the Department's Approved Products List (APL) and approved by the Engineer to restore detection capabilities. Before beginning any construction, submit to the Engineer the names and phone numbers of persons that can be contacted when signal operation malfunctions.

ARTICLE 102-7 is expanded by the following:

Provide off-duty law enforcement officer when required or as directed by the Engineer.

SUBARTICLE 102-11.1 is deleted and the following substituted:

**102-11.1 General:** Devices installed/used on the project on any calendar day or portion thereof, within the Contract Time, including time extensions which may be granted, will be paid for at lump sum price per day or per location

ARTICLE 102-12 is deleted.

ARTICLE 102-13.22 is deleted and the following substituted:

**102-13.22 Maintenance of Traffic Lump Sum:** Price and payment will be full compensation for all work and costs specified under Section 102.

When the proposal does not include a separate item for Maintenance of Traffic, all work and incidental costs specified as being covered under this Section will be included for payment under the several scheduled items of the overall Contract and no separate payment will be made therefore.

**102-13.23 Payment Items:** Payment will be made under the items shown in the Bid Price Proposal.

**LANDSCAPE SOIL LAYER.  
(REV 3-29-17) (7-17)**

SECTION 163 is deleted.

**RAISED RETRO-REFLECTIVE PAVEMENT MARKERS AND BITUMINOUS ADHESIVE.  
(REV 9-28-15) (7-17)**

ARTICLE 706-1 is deleted and the following substituted:

**706-1 Description.**

Remove and properly dispose of existing raised Retro-Reflective Pavement Markers (RPMs) and replace with new RPMs and adhesive as specified in the work document, producing a positive guidance system to supplement other reflective pavement markings.

ARTICLE 706-4 is expanded by the following:

All markers for each work document will be in place before starting the initial 45 day replacement period under traffic.

ARTICLES 706-6 and 706-7 are deleted and the following substituted:

**706-6 Method of Measurement.**

The quantities to be paid for will be the number of RPMs, removed, furnished and installed, completed and accepted.

**706-7 Basis of Payment.**

Payment will be made under the items specified in the Bid Price Proposal.

**THERMOPLASTIC PAVEMENT MARKINGS – HOT SPRAY.  
(REV 9-29-15) (7-17)**

SUBARTICLE 711-2 is deleted and the following substituted:

**711-2 Materials.**

Use only materials listed on the Department’s Approved Product List (APL) meeting the following requirements.

Standard and Refurbishment Thermoplastic .....	971-1 and 971-5
Refurbishment of Existing Stripes .....	971-1, 971-5 and 971-10
Preformed Thermoplastic .....	971-1 and 971-6
Glass Spheres.....	971-1 and 971-2

Use sand materials meeting the requirements of 971-5.4.

The Engineer will take random samples of all material in accordance with the Department’s Sampling, Testing and Reporting Guide schedule.

ARTICLE 711-4 is deleted and the following substituted:

**711-4 Application.**

**711-4.1 General:** Remove existing pavement markings such that scars or traces of removed markings will not conflict with new pavement markings by a method approved by the Engineer. Cost for removing conflicting pavement markings during maintenance of traffic operations to be included in Maintenance of Traffic, Lump Sum.

Before applying pavement markings, remove any material that would adversely affect the bond of the pavement markings by a method approved by the Engineer.

Before applying pavement markings to any portland cement concrete surface, apply a primer, sealer, or surface preparation adhesive of the type recommended by the manufacturer. Offset longitudinal lines at least 2 inches from any longitudinal joints of portland cement concrete pavement.

Apply pavement markings to dry surfaces only, and when the ambient air and surface temperature is at least 50°F and rising for asphalt surfaces and 60°F and rising for concrete surfaces.

Apply pavement markings to the same tolerances in dimensions and in alignment as specified in 710-5. When applying pavement markings over existing markings, ensure that no more than 2 inches on either end and not more than 1 inch on either side of the existing line is visible.

Apply thermoplastic material to the pavement by extrusion or other means approved by the Engineer.

Conduct field tests in accordance with FM 5-541. Take test readings representative of the pavement marking performance. Remove and replace pavement markings not meeting the requirements of this Section at no additional cost to the Department.

Wait at least 14 days after constructing the final asphalt surface course to place thermoplastic pavement markings. Provide temporary pavement markings during the interim period prior to opening the road to traffic.

**711-4.1.1 Preformed Thermoplastic:** Apply markings to dry surfaces only and when ambient air temperature is at least 32°F. Prior to installation, follow the manufacturer's recommendations for pre-heating.

**711-4.2 Thickness:**

**711-4.2.1 Standard Thermoplastic Markings:** Apply or recap standard thermoplastic pavement markings for longitudinal lines to attain a minimum thickness of 0.10 inch or 100 mils and a maximum thickness 0.15 inch or 150 mils maximum thickness, when measured above the pavement surface.

All chevrons, diagonal and transverse lines, messages, symbols, and arrows, wherever located, will have a thickness of 0.09 inch or 90 mils to 0.12 inch or 120 mils when measured above the pavement surface.

Measure, record and certify on Department approved form and submit to the Engineer, the thickness of white and yellow pavement markings in accordance with FM 5-541.

The Engineer will verify the thickness of the pavement markings in accordance with FM 5-541 within 30 days of receipt of the Contractor's certification.

**711-4.2.2 Refurbishment Thermoplastic Markings:** Apply a minimum of 0.06 inch or 60 mils of thermoplastic material. Ensure that the combination of the existing marking and the overlay after application of glass spheres does not exceed the maximum thickness of 0.150 inch or 150 mils for all lines.

Measure, record and certify on Department approved form and submit to the Engineer, the thickness of white and yellow pavement markings in accordance with FM 5-541.

The Engineer will verify the thickness of the pavement markings in accordance with FM 5-541 within 30 days of receipt of the Contractor's certification.

**711-4.2.3 Preformed Thermoplastic:** Apply 0.125 inch or 125 mils of preformed thermoplastic material.

Measure, record and certify on Department approved form and submit to the Engineer, the thickness of the pavement markings in accordance with FM 5-541.

**711-4.3 Retroreflectivity:** Apply white and yellow pavement markings that will attain an initial retroreflectivity of not less than 450 mcd/lx·m<sup>2</sup> and not less than 350 mcd/lx·m<sup>2</sup>, respectively for all longitudinal lines. All chevrons, diagonal lines, stop lines, messages, symbols, and arrows will attain an initial retroreflectivity of not less than 300 mcd/lx·m<sup>2</sup> and 250 mcd/lx·m<sup>2</sup> for white and yellow respectively. All crosswalks and bicycle markings shall attain an initial retroreflectivity of not less than 275 mcd/lx·m<sup>2</sup>.

When using hot spray thermoplastic material, apply white and yellow pavement markings that will attain an initial retroreflectivity of not less than 300 mcd/lx·m<sup>2</sup> and not less than 250 mcd/lx·m<sup>2</sup>, respectively for all longitudinal lines. All pedestrian crosswalks shall attain an initial retroreflectivity of not less than 275 mcd/lx·m<sup>2</sup>.

Measure, record and certify on Department approved form and submit to the Engineer, the retroreflectivity of white and yellow pavement markings in accordance with FM 5-541.

**711-4.4 Glass Spheres:**

**711-4.4.1 Longitudinal Lines:** For standard thermoplastic markings, apply the first drop of Type 4 or larger glass spheres immediately followed by the second drop of Type 1 glass spheres. For refurbishment thermoplastic markings, apply a single drop of Type 3 glass spheres. Apply reflective glass spheres to all markings at the rates determined by the manufacturer’s recommendations.

**711-4.4.2 Chevrons, Diagonal and Transverse Lines, Messages, Symbols, and Arrows:** For standard or refurbishment thermoplastic markings, apply a single drop of Type 1 glass spheres. Apply retroreflective glass spheres to all markings at the rates determined by the manufacturer’s recommendations.

Apply a mixture consisting of 50% glass spheres and 50% sharp silica sand to all standard thermoplastic crosswalk lines at the rates determined by the manufacturer’s recommendations.

**711-4.4.3 Preformed Markings:** These markings are factory supplied with glass spheres and skid resistant material. No additional glass spheres or skid resistant material should be applied during installation.

**TRAFFIC MARKING MATERIALS – THERMOPLASTIC MATERIAL – HOT SPRAY.**

**(REV 3-18-16) (7-17)**

SECTION 971 is expanded by the following new Article:

**971-11 Thermoplastic Material-Hot Spray.**

**971-10.1 General:** This work shall consist of furnishing and applying thermoplastic material when the project requires refurbishing existing thermoplastic stripes. The manufacturer shall utilize alkyd based materials only and shall have the option of formulating the material according to his own specifications. However, the requirements delineated in this Specification and Section 711 shall apply regardless of the type of formulation used.

**971-11.2 Composition:**

Component	White	Yellow
Binder	25.0% minimum	25.0% minimum
TiO <sub>2</sub> (ASTM D-476 Type II Ructile)	10.0% minimum	-
Glass Spheres	35.0% minimum	35.0% minimum
Yellow Pigment	-	% minimum per manufacturer
Calcium Carbonate and Inert Filler (No. 200 sieve)	30.0% maximum	40.0% maximum
Percentages are by Weight		



**971-11.3 Binders:** The manufacturer shall have the option of formulating the material according to his own specifications. However, the physical and chemical properties contained in this Specification shall apply regardless of the type of formulation used. The pigment, beads and filler shall be well dispersed in the resin. The material shall be free from all skins, dirt and foreign objects.

**971-11.4 Physical Requirements:** Sample specimens shall be prepared in accordance with ASTM D-4960.

Procedure shall meet the following requirements:

Property	Test Method	Minimum	Maximum
Water Absorption	ASTM D-570	-	0.5%
Softening Point	ASTM D-36	190°F	-
Low Temperature Stress Resistance	AASHTO T-250	Pass	-
Specific Gravity	Water displacement	1.87	2.3
Indentation Resistance	ASTM D-2240* Shore Durometer, A2	5	30
Impact Resistance	ASTM D-256, Method A	1.0 N·m	-
Flash Point	ASTM D-92	475°F	-

\*The durometer and panel shall be at 110°F with a 4.4 lb load applied. Instrument measurement shall be taken after 15 seconds.

**971-11.4.1 Set To Bear Traffic Time:** The thermoplastic shall set to bear traffic in not more than two minutes.

**971-11.4.2 Retroreflectivity:** The white and yellow pavement markings shall attain an initial retroreflectance of not less than 300 mcd/lx·m<sup>2</sup> and not less than 250 mcd/lx·m<sup>2</sup>, respectively. The retroreflectance of the white and yellow pavement markings at the end of the one year service life shall not be less than 150 mcd/lx·m<sup>2</sup>.

**971-11.4.3 Durability:** Durability is the measured percent of thermoplastic material completely removed from the pavement. The thermoplastic material line loss must not exceed 5.0% at the end of the one year service life.

**971-11.5 Glass Spheres:** Glass spheres shall be Type 1 or high index and meet the requirements of 971-2.

**971-11.6 Sharp Silica Sand:** Sharp silica sand used for bike lane symbols and pedestrian crosswalk lines shall meet the following gradation requirements:

Sieve Size	% Passing
20	100
50	0 to 10

**971-11.7 Application Properties:** The thermoplastic material shall readily apply and adhere to the existing traffic stripe at temperatures as recommended by the manufacturer from equipment approved by the Engineer to produce a line which shall be continuous and uniform in shape having clear and sharp dimensions at a minimum thickness as identified in the plans. No signs of moisture shall be visible on the pavement surface as determined in accordance with the binder manufacturer's recommendations.

The material, when formed into traffic stripes, must be readily renewable by placing an overlay of new material directly over an old line of the same material. Such new material shall bond itself to the old line in a manner such that no splitting or separation occurs.

Overlay stripe thicknesses shall be measured as specified in Section 711 for refurbishing of thermoplastic stripes.

**971-11.8 Packing and Marking:** The thermoplastic material shall be packed in suitable biodegradable or thermo-degradable containers which will not adhere to the product during shipment and storage. The container of thermoplastic material shall weigh approximately 50 lb. The label shall warn the user that the material shall be heated in the range as recommended by the manufacturer.

# **SUPPLEMENTAL SPECIFICATIONS**

**001 DEFINITIONS AND TERMS.**  
**(REV 4-7-17) (FA 4-10-17) (9-17)**

ARTICLE 1-3, the definition for Proposal Form is deleted and the following substituted:

**Proposal Form.**

The official form or the electronically generated bid item sheets on which the Department requires formal bids to be prepared and submitted for the work.

**002 PROPOSAL REQUIREMENTS AND CONDITIONS.**  
**(REV 4-7-17) (FA 4-10-17) (9-17)**

SUBARTICLE 2-2.3 is deleted and the following substituted:

**2-2.3 Internet Bid Submittals:** Unless otherwise indicated in the Advertisement, the Bidder shall use the Department's bid software to prepare a bid for Internet submittal. The Department will accept, as the official bid, the set of Proposal Forms generated from the Department's bid software along with a complete Proposal package, submitted via the Internet in accordance with 2-5 and 2-8. A Digital ID is required to submit a bid via the Internet. Digital IDs may be obtained as outlined in the Advertisement.

The Department will not be responsible for any communications or machine breakdowns, transmission interruptions, delays, or any other problems that interfere with the receipt of Proposals as required above either at the Bidder's transmitting location, at the Department's receiving location, or anywhere between these locations. Receipt or non-receipt of Proposals will not be considered grounds for a bid protest. The Department will not be held responsible if the Bidder cannot complete or submit a bid due to failure or incomplete delivery of the files submitted via the Internet.

SUBARTICLE 2-2.4 is deleted and the following substituted:

**2-2.4 Hard Copy Bid Submittals:** Unless otherwise indicated in the Advertisement, the Bidder shall use the Department's bid software to prepare a bid for hard copy submittal.

The Department will accept, as the official bid, this set of Proposal Forms generated from the Department's bid software along with a complete Proposal package, delivered to the Department in hard copy in accordance with the instructions listed below and the requirements of 2-5 and 2-8.

Print and submit bid item sheets generated from the Department's bid software on letter size paper. Ensure that all computer generated sheets are legible. Do not submit computer generated sheets using a font size smaller than 9 point.

Return the Department's bid software generated Proposal as the official bid, with the Proposal labeled with the Bidder's Name, Vendor Number, Letting Date, Revision Date (if applicable) and the Proposal ID.

SUBARTICLE 2-5.2 is deleted and the following substituted:

**2-5.2 Internet Bid Submittals:** The Bidder shall execute the Proposal under the Bidder's Digital ID and enter the firm's bidding office street address on the Bidders Information Tab in the Department's bid software. This Digital ID represents the firm as an individual, partnership, corporation, limited liability company, or joint venture. By entering and submitting the Digital ID the authorized parties obligate the firm to the bid. Internet Bid Submittals must acknowledge, on behalf of, the person, firm, association, or corporation submitting the bid certifying that such person, firm, association, or corporation has not, either directly or indirectly, entered into any agreement, participated in any collusion, or otherwise taken any action in restraint of free competitive bidding in connection with the submitted bid, by indicating such in the Proposal. The Department will not consider any bid unless such acknowledgement is included.

ARTICLE 2-6 is deleted and the following substituted:

**2-6 Rejection of Irregular Proposals.**

A Proposal is irregular and the Department may reject such Proposal if the Proposal shows omissions, alterations of form, additions not specified or required, conditional or unauthorized alternate bids, or irregularities of any kind; or if the unit prices are obviously unbalanced, or if the cost is in excess of or below the reasonable cost analysis values, or if the Bidder submits a Proposal which was not generated using the Department's bid software.

When the Department provides for alternate bids in the Proposal Form, make only one entry for each alternate. A Proposal that provides for alternative bids is irregular and the Department may reject such Proposal if the Bidder makes entries for more than one alternate.

# APPENDICES

**TECHNICAL SPECIAL PROVISIONS.**

The following Technical Special Provisions are individually signed and sealed but are included as part of this Specifications Package.

TSP 528 DYNAMIC ENVELOPE PATTERNED PAVEMENT AT RAILROAD  
CROSSINGS

**TECHNICAL SPECIAL PROVISION  
FOR  
DYNAMIC ENVELOPE PATTERNED PAVEMENT AT RAILROAD  
CROSSINGS  
SECTION 528**

**FINANCIAL PROJECT ID: 427956-1-72-27  
SEMINOLE AND ORANGE COUNTIES**

The official record of this Technical Special Provision is the electronic file signed and sealed under Rule 61G15-23.004 F.A.C.

Prepared by: Rakesh P. Sharma, P.E.  
P.E. No. 70902  
Date: November 15, 2017  
Pages 1 to 8

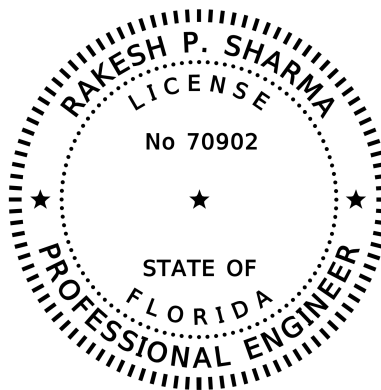

Page 1 of 8



**DYNAMIC ENVELOPE PATTERNED PAVEMENT AT RAILROAD CROSSINGS.  
(REV. 10-5-17)**

The following new Section is added after Section 527:

**528-1 Description.**

Furnish and apply Patterned Pavement at railroad grade crossings for the “Dynamic Envelope” in accordance with this Technical Special Provision (TSP). Install products in accordance with manufacturer’s specifications with the color and pattern as specified in the Plans.

For this specification, Patterned Pavements are defined as a post applied surface marking overlay to either the pavement surface.

Arrange a demonstration with the manufacturer’s representative at the construction site to train Department staff, Construction Engineering & Inspection (CEI) inspector(s), and Contractor personnel prior to surface treatment. Arrange for the manufacturer’s representative to be available during application of the surface treatment.

**528-2 Materials.**

**528-2.1 Polymer Binder:** Binders must be of an amine epoxy base, comprised of a two-component epoxy resin certified by the manufacturer to be suitable for color pigmenting. A maximum in service time of four (4) hours, at an ambient pavement surface temperature of 70° F, is required to meet the specified depth of color.

Use a two-part polymer resin binder treatment capable of retaining a bauxite, synthetic or glass aggregate topping under vehicular traffic conditions and consists of a thermosetting modified polymer compound and meets the requirements in Table 528-1.

Obtain a mixing ratio of 2:1 or a mix proven by the manufacturer for stronger bonding may be allowed upon providing documentation acceptable by the Department. Do not use two-part epoxy materials which are not exothermic in curing and do not meet the viscosity requirement. Provide independent laboratory report documents demonstrating that the epoxy binder meets the requirements of this Section.

**528-2.2 Aggregate:** The aggregate must be a calcined bauxite, synthetic or glass 100% integral opaque yellow colored aggregate consisting of a 1-3 mm gradation. The aggregate must be clean, dry, and free from foreign matter. The aggregate must be delivered to the construction site in packaging that is clearly labeled. Protect the aggregate from any contaminants on the jobsite and from exposure to rain or other moisture. The aggregate must meet the requirements in Table 528-2.

Use only aggregate products approved for use in vehicular traffic areas. Products must meet manufacturer’s specifications for all patterns, textures, templates, sealers, coatings and coloring materials.

Material coatings used to achieve the pattern and color must produce an adherent, weather resistant, skid resistant, wear resistant surface under service conditions. Color must be integral and consistent throughout the installation. Use materials that are characterized as non-hazardous as defined by Resource Conservation and Recovery Act (RCRA), Subpart C, Table 1 of 40 CFR 261.24 “Toxicity Characteristic”.

Materials must not exude fumes which are hazardous, toxic or detrimental to persons or property.

**Table 528-1**

<b>Polymer Resin Binder Requirements</b>		
<b>Property</b>	<b>Requirement</b>	<b>Test Method</b>
Viscosity	7 – 30 poises	ASTM D-2556
Gel Time	10 minutes min.	ASTM C-881 (60-gram mass)
Ultimate Tensile Strength	2000 – 5000 psi	ASTM D-638 (Type 1 Specimen)
Elongation at break point	30 – 70%	ASTM D-638 (Type 1 Specimen)
Durometer Hardness (shore D)	60 - 80	ASTM D-2240
Compressive Strength	1000 psi min 3 hours, 5000 psi min at 7 days	ASTM C-579
Water Absorption	1.0% max	ASTM D-570
Adhesive Strength at 24 hrs	250 psi min or 100% substrate failure	ASTM C-1583
Bleed Test	Minimal to no trace	Swab test visual 7 days @ room temperature

**Table 528-2**

<b>Property</b>	<b>Requirement</b>	<b>Test Methods</b>
Aggregate Abrasion Value	20% max	AASHTO T-96
Aggregate Grading	No. 4 Sieve Size	100% min Passing
	No. 6 Sieve Size	95% min Passing
	No. 16 Sieve Size	5% max Passing
Moisture Content	0.2% max	AASHTO T-255
Aluminum Oxide	86% min	ASTM C-25

Provide independent test data verifying the material meets the requirements of this Section including verification that the product, installed in accordance with the manufacturer’s specifications and procedures, has been tested in accordance with either:

- a. ASTM E-274, Skid Resistance of Paved Surfaces using a standard ribbed full-scale tire at a speed of 40 mph (FN40R), and has a minimum FN40R value of 35, or
- b. ASTM E-1911, Measuring Paved Surface Frictional Properties Using the Dynamic Friction Tester (DFT), at a speed of 40 mph (DFT40), and has a minimum DFT40 value of 40.

**528-2.3 Thermoplastic Pavement Markings:** Apply the thermoplastic edge lines and cross lines per plans.

**528-3 Performance Requirements for Products in Vehicular Travel Areas.**

Department approval will be contingent on a field service test demonstrating that the Patterned Pavement product meets the following performance measures at the end of three years from opening to traffic:

1. The average thickness must be a minimum of 50% of the original thickness.
2. Wearing of the material coating must not expose more than 15% of the underlying surface area as measured within the traveled way.
3. Friction performance of patterned/textured pavement materials must meet or exceed one of the following test method values:
  - a. FN40R value of 35 in accordance with ASTM E-274; or,
  - b. DFT40 value of 40 in accordance with ASTM E-1911

Provide a field service test installation of each product within a marked crosswalk on a roadway with an ADT of 6,000 to 12,000 vehicles per day per lane, on a site approved by the Department. The test installation must be a minimum six feet wide and extend from pavement edge to pavement edge across all traffic lanes and shoulder pavement at the crosswalk location. The test installation must be tested by the manufacturer in accordance with FM 5-592.

#### **528-4 Construction.**

**528-4.1 General:** Do not apply the two-part polymer resin binder on a wet surface, when the ambient or surface temperature is below or above the manufacturer's specifications, or when the anticipated weather conditions would prevent the proper application of the surface treatment as determined by the manufacturer's representative.

**528-4.2 Product Submittals:** Prior to installation, submit pattern and color samples to the Engineer for confirmation that the product meets the pattern and color specified in the Plans. Do not begin installation until acceptance by the Engineer.

**528-4.3 Pavement Cuts:** Complete all utility and other items requiring a cut and installation under the finished surface, prior to product installation. Traffic loop detector installations are not allowed within the Dynamic Envelop.

**528-4.4 Surface Protection:** Protect treated surfaces from traffic and environmental effects until the product is completely installed, including drying and curing according to the manufacturer's instructions.

**528-4.5 Preparation:** Surfaces must be clean, dry, and free of all dust, oil, debris and any other material that might interfere with the bond between the polymer resin binder material and existing surfaces.

Allow for a minimum of thirty (30) calendar days before applying the Patterned Pavement on a new asphalt roadway surface. Asphalt surfaces must be vigorously treated to remove dust laitance and other loose material. The treatment must consist of the application of compressed air or dry surface abrasive blasting as determined by a site inspection. Newly laid asphalt surface must be trafficked for a minimum period of two (2) weeks prior to surface binder application. Any visible oil must be removed by washing and scrubbing the surface with a mild detergent solution and flushing with clean water. The surface must then be allowed to dry prior to surface application of the binder.

Clean concrete pavement surfaces by shot blasting to remove all curing compounds, loosely bonded mortar, dust laitance, surface carbonation, and deleterious material. The final surface must have, at minimum, the texture of Concrete Surface Profile (CSP) 5 as specified by the International Concrete Repair Institute (ICRI). The texture should not go above CSP 7. After shot blasting, vacuum sweep or air wash, with a minimum of 180 cfm of clean and dry compressed air. Maintain the air lance perpendicular to the surface and the tip of the air lance within 12 inches of the surface.

New concrete should be water cured for at least 28 days, well compacted and finished, preferably by power floating or troweling to give a dense smooth finish.

Old concrete must be structurally sound, all loose and deteriorated areas must be replaced, spalled areas repaired and any existing coatings must be removed. The concrete substrate must not have any visible moisture and the surface must be clean, free from dust, oil, grease or other contaminants that may impair the adhesion of the system. Immediately prior to application all surface laitance must be removed by captive shot blasting, scarifying, diamond grinding, hydro blasting or other approved methods. Unless otherwise directed by the engineer all existing road markings, reflective pavement markers (RPMs) and areas in general which are not to receive the treatment.

Protect all utilities drainage structures, curbs and any other structure within or adjacent to the treatment location against the application of the surface treatment materials. Cover and protect all existing pavements and pavement markings that are adjacent to the application surfaces. Remove pavement markings that conflict with the surface application by grinding, or by other methods approved by the Engineer. Sweep the surface clean prior to the polymer binder application.

Pre-treat asphalt joints and cracks greater than 1/4 inch in width and depth with the mixed polymer specified herein. Proceed with the high friction polymer binder and the aggregate topping installation once the polymer in the pre-treated areas has gelled. On concrete, slab repair or replacement is required for any single slab with moderate or severe distress (specifically transverse cracking, longitudinal cracking, spalling, or corner cracking) or a shattered slab in more than three pieces. Install overlay products in areas subject to vehicular traffic to a thickness not exceeding 180 mils. The thermoplastic pavement marking must be laid first on the pavement surface; meet the two-part treatment material overlay thickness for dynamic envelope.

#### **528-4.6 Application:**

Hand-mix the polymer resin binder in accordance with the manufacturer's specifications. Uniformly spread the binder using serrated edge squeegees onto a dry surface at a minimum rate of (20- 23 sq. ft. per gallon) which will vary according to the surface texture and porosity. On a smooth closed textured surface, the amount of binder must not be less than the manufacturer's requirements as required to hold the aggregate permanently in position.

The temperature of binder components heated to facilitate mixing or spray application must be measured using a temperature gauge accurate to  $\pm 2^\circ$  and must not exceed the maximum temperature recommended by the resin manufacturer. Heated binders must be allowed to cool prior to the application of aggregate.

Following binder application, aggregate must be broadcast to cover the binder

uniformly and to excess at a rate of not less than 1.25 lbs. per sq. ft. Rolling of aggregate must not be permitted under any circumstances.

Immediately following application any masking material must be removed together with any binder or aggregate adhering to same. During the cure period, no traffic of any kind must be permitted on the surface treatment.

Upon initial curing, all excess aggregate must be removed by a power sweeper, brooms or equivalent means.

**528-4.7 Installation Acceptance:** Upon completion of the installation, the Engineer will check the area at random locations for geometric accuracy. If any of the chosen areas are found to be deficient, correct the entire patterned area at no additional cost to the Department.

Certify that the Patterned Pavement was installed in accordance with the manufacturer's requirements.

#### **528-5 Vendor Qualification.**

Use a Patterned Pavement vendor that has experience on similar projects on which a minimum of 100 square yards of Patterned Pavement that has been placed within the past three years from the date of the submittal of bid. Provide the owners contact information and project locations. Include documentation that indicates the in-place friction characteristics of these projects met a minimum FN40R of 35 when tested in accordance with ASTM E-274.

#### **528-6 Quality Control Plan.**

Submit a Patterned Pavement Quality Control Plan (QCP) and provide a copy to the State Materials Office (SMO) for approval at least 30 days prior to placement of Patterned Pavement. The QCP must include at a minimum:

1. Schedule for the trial and the production of Patterned Pavement work.
2. Description of equipment for placing Patterned Pavement.
3. Method of application for measuring, mixing, placing, and finishing Patterned Pavement.
4. Method for protecting areas not to receive Patterned Pavement.
5. Description of acceptable environmental conditions for placing Patterned Pavement.
6. Cure time and time to bear traffic estimates for Patterned Pavement.
7. Storage and handling of Patterned Pavement components.
8. Disposal and recycling of excess Patterned Pavement and containers.
9. Contingency plan for possible failure during the Patterned Pavement application.
10. Name of the certified independent testing laboratory.
11. Key personnel and contact information.
12. All project certifications and test results.
13. QC Manager (who has full authority to institute any action necessary for the successful operation of the plan).

**528-7 Warranty and Warranty Bond.**

The complete Dynamic Envelope described under this Technical Special Provision Section shall be warranted by the Contractor and Manufacturer against defects in material and workmanship for a period of 1 year from the date of Final Acceptance. The warranty shall include and provide for the complete removal and replacement of the Dynamic Envelope should the Dynamic Envelope fail to perform as described in Table 528-3 of this Technical Special Provision or appear to deteriorate in any other manner not clearly specified in Manufacturer's published data. The warranty shall be provided by the Contractor to the Department and shall include Labor and Materials for the removal and replacement for a period of 1 year from the date of the Final Acceptance.

Regular and scheduled maintenance may be performed by the Department's maintenance contractor. Maintenance work by the maintenance contractor shall not void the above described warranty of the Dynamic Envelope.

Prior to Final Acceptance, provide a warranty bond covering the warranty described above which will remain in effect for a period of 1 year following Final Acceptance. This bond is separate from and in addition to any bonds required for the Project but shall conform to the same requirements contained within the FDOT Specifications except for the time period which shall be the time period described herein. This Technical Special Provision does not alleviate any requirements nor conflict with any conditions in the FDOT Specifications.

If any manufacturer has a separate and additional warranty for materials, Contractor hereby assigns to the Department any and all manufacturers' or other sellers' warranties that come with any products, material or supplies which are incorporated into or are consumed in the project in any way. To the extent that any such warranties do not extend to subsequent purchasers or owners or such warranties contain a limitation on assignment, Contractor agrees that Contractor purchased the products, materials and supplies on behalf of the Department with the intent that the Department be the intended recipient of any warranties. All documents associated with or describing any such warranties shall be delivered to the Department along with the other project final acceptance documents and shall be deemed to be a part of the required final acceptance documentation. Contractor shall not take any action or fail to act in any way which voids any such warranties. All subcontracts shall contain a similar provision which requires subcontractors to assign any such warranties to the Department.

**Table 528-3**

<b>Warranty Criteria</b>			
<b>Type of Survey</b>	<b>Type of Survey</b>	<b>Threshold Values for Patterned Pavement Application Area</b>	<b>Remedial Work</b>
Surface Cracking <sup>(1)</sup>	Any Survey	≥ 10% of any given 100 square yard of Patterned Pavement application area	Remove and replace the distressed areas Patterned Pavement to the full distressed depth and to a minimum surface area of 150% of each distressed area, subject to performance at final <sup>(2)</sup>
Raveling and/or Delamination <sup>(3)</sup>	Any Survey	≥ 10% of any given 100 square yard of Patterned Pavement application area	Grind and replace the full distressed depth area(s) with Patterned Pavement to the full distressed depth and to a minimum surface area of 150% of each distressed area, subject to performance at final survey <sup>(4)</sup>
Soft Spots/Bleeding <sup>(5)</sup>	Any Survey	≥ 10% of any given 100 square yard of Patterned Pavement application area	Grind and replace the full distressed depth area(s) with Patterned Pavement to the full distressed depth and to a minimum surface area of 150% of each distressed area, subject to performance at final survey <sup>(4)</sup>
<p>(1) Severity of Cracking Class IB or greater.                      (2) Remedial Work for surface cracking: All corrective work must be performed to the satisfaction of the Engineer.                      (3) Raveling and/or Delamination: Loss of cover aggregate or lack of Patterned Pavement mix on the surface.                      (4) At the time of final survey, repaired areas must be performing to the satisfaction of the Engineer.                      (5) Soft Spots is caused by uncured or polymer binder and bleeding is due to excess binder. The soft spots can be detected and verified by using a small scraper knife to shovel off the material.</p>			

**528-8 Method of Measurement.**

Price and payment will be full compensation for all work specified in this Section, including materials and incidentals necessary to complete the work.

**528-9 Basis of Payment.**

Payment will be made under the items specified in the Bid Price Proposal.

**THIS COMPLETES  
THIS  
SPECIFICATIONS  
PACKAGE**



## STANDARD CONTRACT TERMS AND CONDITIONS

The following form PUR 1001 is a standard contract terms form that the Department includes in all procurements, except that paragraphs 3, 4, 5, 12, 13, 14, 19, 20, and 21 do not apply to this Request for Proposal. Deletion of these paragraphs shall not be deemed to be deletion of content contained elsewhere and the substance of these excepted paragraphs may be addressed in other locations in the procurement documents. That substance located elsewhere continues to apply regardless of this exception paragraph.

### State of Florida PUR 1001 General Instructions to Respondents

#### Contents

1. Definitions.
2. General Instructions.
- ~~3. Electronic Submission of Responses.~~
- ~~4. Terms and Conditions.~~
- ~~5. Questions.~~
6. Conflict of Interest.
7. Convicted Vendors.
8. Discriminatory Vendors.
9. Respondent's Representation and Authorization.
10. Manufacturer's Name and Approved Equivalents.
11. Performance Qualifications.
- ~~12. Public Opening.~~
- ~~13. Electronic Posting of Notice of Intended Award.~~
- ~~14. Firm Response.~~
15. Clarifications/Revisions.
16. Minor Irregularities/Right to Reject.
17. Contract Formation.
18. Contract Overlap.
- ~~19. Public Records.~~
- ~~20. Protests.~~
- ~~21. Limitation on Vendor Contact with Agency During Solicitation Period~~

**1. Definitions.** The definitions found in s. 60A-1.001, F.A.C. shall apply to this agreement. The following additional terms are also defined:

- (a) "Buyer" means the entity that has released the solicitation. The "Buyer" may also be the "Customer" as defined in the PUR 1000 if that entity meets the definition of both terms.
- (b) "Procurement Officer" means the Buyer's contracting personnel, as identified in the Introductory Materials.
- (c) "Respondent" means the entity that submits materials to the Buyer in accordance with these Instructions.
- (d) "Response" means the material submitted by the respondent in answering the solicitation.
- (e) "Timeline" means the list of critical dates and actions included in the Introductory Materials.

**2. General Instructions.** Potential respondents to the solicitation are encouraged to carefully review all the materials contained herein and prepare responses accordingly.

**3. Electronic Submission of Responses.** Respondents are required to submit responses electronically. For this purpose, all references herein to signatures, signing requirements, or other required acknowledgments hereby include electronic signature by means of clicking the "Submit Response" button (or other similar symbol or process) attached to or logically associated with the response created by the respondent within MyFloridaMarketPlace. The respondent agrees that the action of electronically submitting its response constitutes:

- an electronic signature on the response, generally,
- an electronic signature on any form or section specifically calling for a signature, and
- an affirmative agreement to any statement contained in the solicitation that requires a definite confirmation or acknowledgement.

**4. Terms and Conditions.** All responses are subject to the terms of the following sections of this solicitation, which, in case of conflict, shall have the order of precedence listed:

- Special Conditions and Instructions,
- Instructions to Respondents (PUR 1001),
- General Conditions (PUR 1000), and Introductory Materials.

The Buyer objects to and shall not consider any additional terms or conditions submitted by a respondent, including any appearing in documents attached as part of a respondent's response. In submitting its response, a respondent agrees that any additional terms or conditions, whether submitted intentionally or inadvertently, shall have no force or effect. Failure to comply with terms and conditions, including those specifying information that must be submitted with a response, shall be grounds for rejecting a response.

**5. Questions.** Respondents shall address all questions regarding this solicitation to the Procurement Officer. Questions must be submitted via the Q&A Board within MyFloridaMarketPlace and must be RECEIVED NO LATER THAN the time and date reflected on the Timeline. Questions shall be answered in accordance with the Timeline. All questions submitted shall be published and answered in a manner that all respondents will be able to view. Respondents shall not contact any other employee of the Buyer or the State for information with respect to this solicitation. Each respondent is responsible for monitoring the MyFloridaMarketPlace site for new or changing information. The Buyer shall not be bound by any verbal information or by any written information that is not contained within the solicitation documents or formally noticed and issued by the Buyer's contracting personnel. Questions to the Procurement Officer or to any Buyer personnel shall not constitute formal protest of the specifications or of the solicitation, a process addressed in paragraph 19 of these Instructions.

**6. Conflict of Interest.** This solicitation is subject to chapter 112 of the Florida Statutes. Respondents shall disclose with their response the name of any officer, director, employee or other agent who is also an employee of the State. Respondents shall also disclose the name of any State employee who owns, directly or indirectly, an interest of five percent (5%) or more in the respondent or its affiliates.

**7. Convicted Vendors.** A person or affiliate placed on the convicted Vendor list following a conviction for a public entity crime is prohibited from doing any of the following for a period of 36 months from the date of being placed on the convicted Vendor list:

- submitting a bid on a contract to provide any goods or services to a public entity;
- submitting a bid on a contract with a public entity for the construction or repair of a public building or public work;
- submitting bids on leases of real property to a public entity;
- being awarded or performing work as a contractor, supplier, subcontractor, or consultant under a contract with any public entity; and

- transacting business with any public entity in excess of the Category Two threshold amount (\$25,000) provided in section 287.017 of the Florida Statutes.

**8. Discriminatory Vendors.** An entity or affiliate placed on the discriminatory vendor list pursuant to section 287.134 of the Florida Statutes may not:

- submit a bid on a contract to provide any goods or services to a public entity;
- submit a bid on a contract with a public entity for the construction or repair of a public building or public work;
- submit bids on leases of real property to a public entity;
- be awarded or perform work as a contractor, supplier, sub-contractor, or consultant under a contract with any public entity; or
- transact business with any public entity.

**9. Respondent's Representation and Authorization.** In submitting a response, each respondent understands, represents, and acknowledges the following (if the respondent cannot so certify to any of following, the respondent shall submit with its response a written explanation of why it cannot do so).

- The respondent is not currently under suspension or debarment by the State or any other governmental authority.
- To the best of the knowledge of the person signing the response, the respondent, its affiliates, subsidiaries, directors, officers, and employees are not currently under investigation by any governmental authority and have not in the last ten (10) years been convicted or found liable for any act prohibited by law in any jurisdiction, involving conspiracy or collusion with respect to bidding on any public contract.
- Respondent currently has no delinquent obligations to the State, including a claim by the State for liquidated damages under any other contract.
- The submission is made in good faith and not pursuant to any agreement or discussion with, or inducement from, any firm or person to submit a complementary or other noncompetitive response.
- The prices and amounts have been arrived at independently and without consultation, communication, or agreement with any other respondent or potential respondent; neither the prices nor amounts, actual or approximate, have been disclosed to any respondent or potential respondent, and they will not be disclosed before the solicitation opening.
- The respondent has fully informed the Buyer in writing of all convictions of the firm, its affiliates (as defined in section 287.133(1)(a) of the Florida Statutes), and all directors, officers, and employees of the firm and its affiliates for violation of state or federal antitrust laws with respect to a public contract for violation of any state or federal law involving fraud, bribery, collusion, conspiracy or material misrepresentation with respect to a public contract. This includes disclosure of the names of current employees who were convicted of contract crimes while in the employ of another company.
- Neither the respondent nor any person associated with it in the capacity of owner, partner, director, officer, principal, investigator, project director, manager, auditor, or position involving the administration of federal funds:
  - Has within the preceding three years been convicted of or had a civil judgment rendered against them or is presently indicted for or otherwise criminally or civilly charged for: commission of fraud or a criminal offense in connection with obtaining, attempting to obtain, or performing a federal, state, or local government transaction or public contract; violation of federal or state antitrust statutes; or commission of embezzlement, theft, forgery, bribery, falsification or destruction of records, making false statements, or receiving stolen property; or
  - Has within a three-year period preceding this certification had one or more federal, state, or local government contracts terminated for cause or default.

- The product offered by the respondent will conform to the specifications without exception.
- The respondent has read and understands the Contract terms and conditions, and the submission is made in conformance with those terms and conditions.
- If an award is made to the respondent, the respondent agrees that it intends to be legally bound to the Contract that is formed with the State.
- The respondent has made a diligent inquiry of its employees and agents responsible for preparing, approving, or submitting the response, and has been advised by each of them that he or she has not participated in any communication, consultation, discussion, agreement, collusion, act or other conduct inconsistent with any of the statements and representations made in the response.
- The respondent shall indemnify, defend, and hold harmless the Buyer and its employees against any cost, damage, or expense which may be incurred or be caused by any error in the respondent's preparation of its bid.
- All information provided by, and representations made by, the respondent are material and important and will be relied upon by the Buyer in awarding the Contract. Any misstatement shall be treated as fraudulent concealment from the Buyer of the true facts relating to submission of the bid. A misrepresentation shall be punishable under law, including, but not limited to, Chapter 817 of the Florida Statutes.

**10. Manufacturer's Name and Approved Equivalents.** Unless otherwise specified, any manufacturers' names, trade names, brand names, information or catalog numbers listed in a specification are descriptive, not restrictive. With the Buyer's prior approval, the Contractor may provide any product that meets or exceeds the applicable specifications. The Contractor shall demonstrate comparability, including appropriate catalog materials, literature, specifications, test data, etc. The Buyer shall determine in its sole discretion whether a product is acceptable as an equivalent.

**11. Performance Qualifications.** The Buyer reserves the right to investigate or inspect at any time whether the product, qualifications, or facilities offered by Respondent meet the Contract requirements. Respondent shall at all times during the Contract term remain responsive and responsible. In determining Respondent's responsibility as a Vendor, the agency shall consider all information or evidence which is gathered or comes to the attention of the agency which demonstrates the Respondent's capability to fully satisfy the requirements of the solicitation and the contract.

Respondent must be prepared, if requested by the Buyer, to present evidence of experience, ability, and financial standing, as well as a statement as to plant, machinery, and capacity of the respondent for the production, distribution, and servicing of the product bid. If the Buyer determines that the conditions of the solicitation documents are not complied with, or that the product proposed to be furnished does not meet the specified requirements, or that the qualifications, financial standing, or facilities are not satisfactory, or that performance is untimely, the Buyer may reject the response or terminate the Contract. Respondent may be disqualified from receiving awards if respondent, or anyone in respondent's employment, has previously failed to perform satisfactorily in connection with public bidding or contracts. This paragraph shall not mean or imply that it is obligatory upon the Buyer to make an investigation either before or after award of the Contract, but should the Buyer elect to do so, respondent is not relieved from fulfilling all Contract requirements.

**12. Public Opening.** ~~Responses shall be opened on the date and at the location indicated on the Timeline. Respondents may, but are not required to, attend. The Buyer may choose not to announce prices or release other materials pursuant to s. 119.071(1)(b), Florida Statutes. Any person requiring a special accommodation because of a disability should contact the Procurement Officer at least five (5) workdays prior to the solicitation opening. If you are hearing or speech impaired, please contact the Buyer by using the Florida Relay Service at (800) 955-8771 (TDD).~~

~~**13. Electronic Posting of Notice of Intended Award.** Based on the evaluation, on the date indicated on the Timeline the Buyer shall electronically post a notice of intended award at [http://fen.state.fl.us/owa\\_vbs/owa/vbs\\_www.main\\_menu](http://fen.state.fl.us/owa_vbs/owa/vbs_www.main_menu). If the notice of award is delayed, in lieu of posting the notice of intended award the Buyer shall post a notice of the delay and a revised date for posting the notice of intended award. Any person who is adversely affected by the decision shall file with the Buyer a notice of protest within 72 hours after the electronic posting. The Buyer shall not provide tabulations or notices of award by telephone.~~

~~**14. Firm Response.** The Buyer may make an award within sixty (60) days after the date of the opening, during which period responses shall remain firm and shall not be withdrawn. If award is not made within sixty (60) days, the response shall remain firm until either the Buyer awards the Contract or the Buyer receives from the respondent written notice that the response is withdrawn. Any response that expresses a shorter duration may, in the Buyer's sole discretion, be accepted or rejected.~~

**15. Clarifications/Revisions.** Before award, the Buyer reserves the right to seek clarifications or request any information deemed necessary for proper evaluation of replies from all respondents deemed eligible for Contract award. Failure to provide requested information may result in rejection of the response.

**16. Minor Irregularities/Right to Reject.** The Buyer reserves the right to accept or reject any and all bids, or separable portions thereof, and to waive any minor irregularity, technicality, or omission if the Buyer determines that doing so will serve the State's best interests. The Buyer may reject any response not submitted in the manner specified by the solicitation documents.

**17. Contract Formation.** The Buyer shall issue a notice of award, if any, to successful respondent(s), however, no contract shall be formed between respondent and the Buyer until the Buyer signs the Contract. The Buyer shall not be liable for any costs incurred by a respondent in preparing or producing its response or for any work performed before the Contract is effective.

**18. Contract Overlap.** Respondents shall identify any products covered by this solicitation that they are currently authorized to furnish under any state term contract. By entering into the Contract, a Contractor authorizes the Buyer to eliminate duplication between agreements in the manner the Buyer deems to be in its best interest.

~~**19. Public Records.** Article 1, section 24, Florida Constitution, guarantees every person access to all public records, and Section 119.011, Florida Statutes, provides a broad definition of public record. As such, all responses to a competitive solicitation are public records unless exempt by law. Any respondent claiming that its response contains information that is exempt from the public records law shall clearly segregate and mark that information and provide the specific statutory citation for such exemption.~~

~~**20. Protests.** Any protest concerning this solicitation shall be made in accordance with sections 120.57(3) and 287.042(2) of the Florida Statutes and chapter 28-110 of the Florida Administrative Code. Questions to the Procurement Officer shall not constitute formal notice of a protest. It is the Buyer's intent to ensure that specifications are written to obtain the best value for the State and that specifications are written to ensure competitiveness, fairness, necessity and reasonableness in the solicitation process.~~

~~Section 120.57(3)(b), F.S. and Section 28-110.003, Fla. Admin. Code require that a notice of protest of the solicitation documents shall be made within seventy-two hours after the posting of the solicitation.~~

~~Section 120.57(3)(a), F.S. requires the following statement to be included in the solicitation: "Failure to file a protest within the time prescribed in section 120.57(3), Florida Statutes, shall constitute a waiver of proceedings under Chapter 120, Florida Statutes."~~

~~Section 28-110.005, Fla. Admin. Code requires the following statement to be included in the solicitation: "Failure to file a protest within the time prescribed in Section 120.57(3), Florida Statutes, or failure to post the bond or other security required by law within the time allowed for filing a bond shall constitute a waiver of proceedings under Chapter 120, Florida Statutes."~~

~~**21. Limitation on Vendor Contact with Agency During Solicitation Period.** Respondents to this solicitation or persons acting on their behalf may not contact, between the release of the solicitation and the end of the 72-hour period following the agency posting the notice of intended award, excluding Saturdays, Sundays, and state holidays, any employee or officer of the executive or legislative branch concerning any aspect of this solicitation, except in writing to the procurement officer or as provided in the solicitation documents. Violation of this provision may be grounds for rejecting a response.~~

DISTRICT FIVE SUNRAIL QUIET ZONE SPECIAL PAVEMENT MARKINGS  
RFP-DOT-17-18-5006-SQZ  
EXHIBIT "B"  
METHOD OF COMPENSATION

1.0 PURPOSE

This Exhibit defines the limits and method of compensation to be made to the Vendor for services set forth in Exhibit "A" and the method by which payments shall be made. For the satisfactory performance of the services detailed in Exhibit "A" Scope of Services, the Vendor shall be paid a Lump Sum Amount of \$ \_\_\_\_\_.

2.0 COMPENSATION

Lump Sum

Vendor will be paid the lump sum amount in full for proper completion of all the work identified to be included in the lump sum amount, regardless of the time, effort, or expense of the Vendor in performing that work. The Vendor may be paid a portion of the lump sum amount as a progress payment based on the percentage of the total lump sum work that has been completed, accepted by the Department, and properly invoiced by the Vendor during any billing period. Payment of the lump sum amount will constitute full compensation for the work and no additional compensation will be paid for overhead, operating margin, expenses, travel, costs, or any other matter.

3.0 INVOICING AND PROGRESS PAYMENTS

Request payment for work completed and accepted by the Department by submitting an invoice using the pay items and unit prices contained in the Contract. Include the Contract Number, the Financial Project Number, the Invoice Number, the Invoice Date and the period that the invoice represents. If required by the Engineer, furnish photos of the completed work at each location with the invoice. Submit the invoice no more often than once every 28 days to the Engineer in charge of the project. Upon receipt and approval, payment will be made less an amount retained or withheld in the Contract.

For Lump Sum contracts, within 21 calendar days after contract award or at the pre-work meeting, whichever is earlier, prepare and submit to the Engineer a schedule of values. With the Engineer's approval, the schedule of values will be the basis for determining monthly payments.

Invoices shall be submitted to:

Florida Department of Transportation  
Contracts Office  
719 S Woodland Blvd

#### 4.0 PROJECT CLOSEOUT

If requested, the Vendor will permit the Department to perform, or have performed, an audit of the records of the Vendor and any or all sub-Vendors to support the compensation paid the Vendor. The audit will be performed as soon as practical after completion and acceptance of the contracted services. In the event funds paid to the Vendor under this agreement are subsequently properly disallowed by the Department because of accounting errors or changes not in conformity with this Agreement, the Vendor agrees that such disallowed amounts are due to the Department on demand. Further, the Department will have the right to deduct from any payment due the Vendor under any other contract any amount due the Department.

#### 5.0 TANGIBLE PERSONAL PROPERTY

This contract does not involve the purchase of Tangible Personal Property, as defined in Chapter 273, F.S.



Exhibit "C", Insurance Provisions for Rail projects

The Contractor must maintain the required insurance coverage shown in this Exhibit for the duration of the project.

General Liability Insurance:

The Vendor must carry and keep in force during the period of this contract a general liability insurance policy or policies with a company authorized to do business in the state of Florida, affording public liability insurance with combined bodily injury limits of at least \$ (2,000,000.00 minimum) per person and \$ (6,000,000.00 minimum) each occurrence, and property damage insurance of at least \$ (2,000,000.00 minimum) each occurrence, for the services to be rendered in accordance with this contract.

(1) **FELA and Workers' Compensation Insurance:** Vendor shall provide coverage under the Federal Employers' Liability Act (FELA) in the greater of the amount required by federal law or a limit of not less than \$1,000,000 for all damages arising out of bodily injuries to, or death of, one person and, subject to that limit for each person, a total limit of \$5,000,000 for all damages arising out of bodily injuries to, or death of, two or more persons in any one occurrence.

To the extent that FELA does not apply, Vendor shall provide Workers' Compensation Insurance in accordance with the laws of the State of Florida and in amounts sufficient to secure the benefits of the Florida Workers' Compensation Law for all employees. If subletting any of the work, ensure that the employees of the subcontractors are covered by similar insurance. Ensure that any equipment rental agreements that include operators who are employees of independent Contractors, sole proprietorships or partners are covered by similar insurance. The Department will accept equivalent approved protection in lieu of insurance.

(2) **Contractors' Public Liability and Property Damages Liability Insurance:** Vendor shall furnish evidence to the Department that, with respect to the operations performed, regular Contractors' Public Liability Insurance providing for a limit of not less than \$1,000,000 for all damages arising out of bodily injuries to, or death of, one person and, subject to that limit for each person, a total limit of \$5,000,000 for all damages arising out of bodily injuries to, or death of, two or more persons in any one occurrence; and regular Contractors' Property Damage Liability Insurance providing for a limit of not less than \$50,000 for all damages arising out of injury to, or destruction of, property in any one occurrence and, subject to that limit per occurrence, a total (or aggregate) limit of \$100,000 for all damages arising out of injury to, or destruction of, property during the policy period is carried.

Vendor shall cause the Department, and National Railroad Passenger Corporation (a/k/a "Amtrak"), and Florida Central Railroad Company, Inc., and Central Florida Commuter Rail Commission, and Volusia County, and Seminole County, and Orange County, and Osceola County, and City of Orlando, to be each an additional insured party on the Contractor's Public Liability and Property Damages Liability policies that insure the Contractor for the described work that it performs under the Contract.

(3) **Contractors' Protective Public Liability and Property Damage Liability Insurance:** Vendor shall furnish evidence to the Department that, with respect to the operations performed by subcontractors, regular Contractors' Protective Public Liability Insurance providing for a limit of not less than \$1,000,000 for all damages arising out of bodily injuries to, or death of, one person and, subject to that limit for each person, a total limit of \$5,000,000 for all damages arising out of bodily injuries to, or death of, two or more persons in any one occurrence; and regular Contractors' Protective Property Damage Liability Insurance providing

for a limit of not less than \$50,000 for all damages arising out of injury to, or destruction of, property in any one occurrence and, subject to that limit per occurrence, a total (or aggregate) limit of \$100,000 for all damages arising out of injury to, or destruction of, property during the policy period is carried.

Vendor shall cause the Department, and National Railroad Passenger Corporation (a/k/a "Amtrak"), and Florida Central Railroad Company, Inc., and Central Florida Commuter Rail Commission, and Volusia County, and Seminole County, and Orange County, and Osceola County, and City of Orlando, to be each an additional insured party on the Contractor's Protective Public Liability and Property Damage Liability Insurance policies that insure the Contractor for the described work that it performs under the Contract.

#### **4. Insurance Required for Construction at Railroads:**

(A) **General:** In addition to any other forms of insurance or bonds required under the terms of the Contract, when the Contract includes the construction of a railroad grade crossing, overpass, or underpass structure, or a railroad crossing signal installation, or any other work or operations by the Contractor within the limits of the railroad right-of-way, including any encroachments thereon from work or operations in the vicinity of the railroad right-of-way, Vendor shall provide insurance of the types set forth below and in amounts not less than specified herein.

(B) **Railroads' Protective Public Liability and Property Damage Liability Insurance:** Vendor shall furnish the Department with an original insurance policy that, with respect to the operations performed, will provide, in behalf of the railroad company regular liability insurance providing coverage for bodily injury, death, and property damage limited to a combined single limit of \$2,000,000 per occurrence with an aggregate limit of \$6,000,000 for the term of the policy.

CSX Transportation, Inc. and the Department are to be each a Named Insured on the policy. National Railroad Passenger Corporation (a/k/a "Amtrak"), and Florida Central Railroad Company, Inc., and Central Florida Commuter Rail Commission, and Volusia County, and Seminole County, and Orange County, and Osceola County, and City of Orlando are to be each an additional insured on the policy.

(5) **Insurance for Protection of Utility Owners:** When the work under the Contract involves work on or in the vicinity of utility-owned property or facilities, Vendor shall furnish the Department with evidence that, with respect to the operations performed, General Comprehensive Liability Insurance or its equivalent providing for a limit of not less than \$1,000,000 for bodily injury or death to person(s) per occurrence and \$300,000 property damage each occurrence is carried.

The Department and Utility Company are to be Additional Named Insureds, and the policy will be primary to any coverage maintained by the Department or Company. National Railroad Passenger Corporation (a/k/a "Amtrak"), and Florida Central Railroad Company, Inc., and Central Florida Commuter Rail Commission, and Volusia County, and Seminole County, and Orange County, and Osceola County, and City of Orlando, are each to be additional insured on the policy. Vendor shall not make any material change or cancellation to the policy without providing the Department with ten days prior written notice.

(6) **Insurance by Others:** Vendor shall require every subcontractor or other third party who may have a contract with Vendor and who may require access on or to State Property or the Corridor or the Sun Rail Corridor or the FCEN Corridor to obtain and maintain for the duration of such access an insurance policy or policies with coverage that satisfies the conditions stated in this section 4. B. paragraphs (1), (2), (3), (4), and (5), and including causing each of the Named Insureds and the additional insureds stated in those paragraphs to be Named Insureds and additional insureds on such subcontractor or third party policy or policies.

For purposes of this section 4.B. paragraph (6) the following apply: "State Property" has the meaning stated in the "TRANSITION AGREEMENT Between State of Florida Department of Transportation and CSX Transportation, Inc.," Appendix A, at page A-4; and "Corridor" has the meaning stated in the "INTERLOCAL OPERATING AGREEMENT FOR OPERATION OF THE CENTRAL FLORIDA COMMUTER RAIL SYSTEM By and Between FLORIDA DEPARTMENT OF TRANSPORTATION AND CENTRAL FLORIDA COMMUTER RAIL COMMISSION," Appendix A, at page A-3; and Sun Rail "Corridor" has the meaning stated in the "AGREEMENT BETWEEN NATIONAL RAILROAD PASSENGER CORPORATION AND THE FLORIDA DEPARTMENT OF TRANSPORTATION," Definitions, at page 6; and "FCEN Corridor" has the meaning stated in the "OPERATING AGREEMENT Between State of Florida Department of Transportation, an agency of the State of Florida, and Florida Central Railroad Company, Inc., a Florida Corporation," Definitions, at page 6. Those agreement definitions mentioned above, and as heretofore amended, are incorporated by reference and may be accessed at [www.sunrail.com](http://www.sunrail.com).

(7) **Submission and Approval of Policies; Termination:** Certificates of insurance (and other evidence of insurance requested by the Department) for each required policy shall be provided by Vendor at the time of Contract execution.

Vendor shall provide all insurance policies in such form and with insurers that are acceptable to the Department. Keep such insurance in force, in the full amount specified herein, until this contract is ended.

**State of Florida  
Department of Transportation**



**FORMS**

REQUEST FOR PROPOSAL

**Sunrail Quiet Zone – Special Pavement  
Markings**

**RFP-DOT-17-18-5006-SQZ**

1. Registration Form
2. Bid Price Proposal Form
3. Work Experience Form
4. Vendor Data Sheet
5. Public Records Request Form
6. Drug-Free Workplace Program Certification
7. DBE Form
8. Bid Opportunity List
9. Bid Bond
10. Performance Bond
11. Proposal Of Form
12. Copies of all addenda acknowledgements

State of Florida  
Department of Transportation  
District Five  
719 S Woodland Blvd  
Deland, FL 32720

**INVITATION TO BID REGISTRATION**  
\*\*\*\*\*  
**PLEASE COMPLETE AND RETURN THIS FORM ASAP**  
**FAX TO (850) 412-8092**  
\*\*\*\*\*

Bid Number: RFP-DOT-17-18-5006-SQZ

Title: Sunrail Quiet Zone - Special Pavement Markings

Potential bidders should notify our office by returning this Bid Registration Form as soon as possible after downloading. Complete the information below and fax this sheet only to the Florida Department of Transportation Procurement Office at (850) 412-8092.

**THE INVITATION TO BID DOCUMENT YOU RECEIVED IS SUBJECT TO CHANGE. Notice of changes (Addenda), will be posted on the Florida Vendor Bid System at [www.myflorida.com](http://www.myflorida.com), under this bid number (click on “BUSINESS”, click on “Doing Business with the State”, under “Everything for Vendors and Customers”, click on “Vendor Bid System (VBS)”, then click on “Search Advertisements”, click on the drop-down arrow beside the box under Advertisement Type, select Competitive Solicitation, click on the drop-down arrow beside the box under Agency, select DEPARTMENT OF TRANSPORTATION, then go to the bottom of the same page and click on Advertisement Search. It is the responsibility of all potential bidders to monitor this site for any changing information prior to submitting your bid.**

Company Name: \_\_\_\_\_

Address: \_\_\_\_\_

City, State, Zip: \_\_\_\_\_

Telephone: (\_\_\_\_) \_\_\_\_\_ Fax Number: (\_\_\_\_) \_\_\_\_\_

Contact Person: \_\_\_\_\_

Internet E-Mail Address: \_\_\_\_\_

For further information on this process, e-mail or telephone the contact listed on the Cover Sheet.

# BID SHEET

**BID #:** RFP-DOT-17-18-5006-SQZ

Item No.	Description	Amount
1	0999-2, Lump Sum Contract, Alternative Bidding	\$

Proposers shall complete this form as presented and shall not modify, add, or delete any items from this form.

**NOTE:** In submitting a response, the bidder acknowledges they have read and agree to the solicitation terms and conditions and their submission is made in conformance with those terms and conditions.

**ACKNOWLEDGEMENT:** I certify that I have read and agree to abide by all terms and conditions of this solicitation and that I am authorized to sign for the bidder. I certify that the response submitted is made in conformance with all requirements of the solicitation.

Bidder: \_\_\_\_\_ FEID# \_\_\_\_\_.

Address: \_\_\_\_\_ City, State, Zip: \_\_\_\_\_

Phone: \_\_\_\_\_ Fax: \_\_\_\_\_ E-mail: \_\_\_\_\_

Authorized Signature: \_\_\_\_\_ Date: \_\_\_\_\_

Printed/Typed: \_\_\_\_\_ Title: \_\_\_\_\_.

## Experience in Pavement Markings

**This Form is for Bidder's to list their work experience.**

850-070-06  
MAINTENANCE - 05/11

RFP-DOT-17-18-5006-SQZ

**F**

**Bidder's Name (please print Company name)**

**Contract ID**

**Bidder's FEID Number**

Experience in **Pavement Markings** is required to bid on this project as defined below.

- 1) For this Contract the Contractor is required to have at least three (3) years of experience in the performance of Pavement Markings, or the Project Superintendent must have at least three (3) years of like experience as a Superintendent. This Form must be filled out and submitted with the bid to the District Contract Administrator. This form must be signed by the Owner or an Officer of the Company and dated in the space provided on the back (page 2) of this form.
- 2) A Contractor that presently has a certificate of prequalified with the Department in "**Pavement Markings**" will suffice to meet the above requirements. If the Contractor is prequalified as stated, mark an "X" in this space (\_\_\_) and Sign and Date below.

**LIST COMPANY EXPERIENCE**

Project Name/Number	Project Location ( City, State )	Type of Pavement Marking Work Performed	Owner/Contact Name Contact Phone Number	Prime or Sub	Beginning Mo / Year	Contract Duration
						Days
						Days
						Days
						Days
						Days
						Days
						Days
						Days
						Days

Signature Required and Additional Data space on the back (page 2) of this form.

**LIST ADDITIONAL COMPANY EXPERIENCE**

Project Name/Number	Project Location ( City, State )	Type of Pavement Marking Work Performed	Owner/Contact Name Contact Phone Number	Prime or Sub	Month/ Year	Contract Duration
						Days
						Days
						Days
						Days

**LIST PROJECT SUPERINTENDENT'S EXPERIENCE**

Project Name/Number	Project Location ( City, State )	Type of Pavement Marking Work Performed	Owner/Contact Name Contact Phone Number	Prime or Sub	Month/ Year	Contract Duration
						Days
						Days
						Days
						Days
						Days
						Days
						Days
						Days
						/ / 20
<b>Print Name of the Owner or Company Officer</b>		<b>Signature of the Owner or Company Officer</b>				



**VENDOR DATA SHEET**  
**RFP-DOT-17-18-5006-SQZ**

VENDOR INFORMATION

DATE: \_\_\_\_\_

FEDERAL EMPLOYER IDENTIFICATION NUMBER (FEID): \_\_\_\_\_  
Attach your W-9 Form (State Purchasing System (SPURS) Vendor  
Number) <https://flvendor.myfloridacfo.com/>

VENDOR NAME: \_\_\_\_\_

CORPORATE STRUCTURE: (Inc. /LLC): \_\_\_\_\_

ADDRESS: \_\_\_\_\_

CITY, STATE, ZIP: \_\_\_\_\_

TELEPHONE: \_\_\_\_\_

CELLULAR: \_\_\_\_\_

TOLL FREE NO.: (800) \_\_\_\_\_ FAX NO.: \_\_\_\_\_ / \_\_\_\_\_

INTERNET E-MAIL ADDRESS: \_\_\_\_\_

INTERNET WEBSITE URL: \_\_\_\_\_

LOCAL OFFICE INFORMATION, (If other than above)

CONTACT NAME: \_\_\_\_\_

ALTERNATE CONTACT: \_\_\_\_\_

ADDRESS: \_\_\_\_\_

CITY, STATE, ZIP: \_\_\_\_\_

TELEPHONE: \_\_\_\_\_

CELLULAR: \_\_\_\_\_

TOLL FREE NO.: (800) \_\_\_\_\_ FAX NO.: \_\_\_\_\_ / \_\_\_\_\_

INTERNET E-MAIL ADDRESS: \_\_\_\_\_

**Requirements**

1) REGISTERED IN MYFLORIDAMARKETPLACE: (Y/N) \_\_\_\_\_ Attach Proof  
<https://vendor.myfloridamarketplace.com>

2) REGISTERED WITH THE DIVISION OF CORPORATIONS(Y/N) \_\_\_\_\_ Attach Proof  
<http://www.sunbiz.org>

3) LICENSED TO CONDUCT BUSINESS IN THE STATE OF FLORIDA (Y/N) \_\_\_\_\_ Attach Proof

\_\_\_\_\_  
(Signature in blue INK)

\_\_\_\_\_  
(Title)

STATE OF FLORIDA DEPARTMENT OF TRANSPORTATION  
**PUBLIC RECORDS FORM**

375-030-61  
PROCUREMENT  
OGC – 06/13

Contract No: TBD

Financial Project No(s): 427956-1-72-27

Project Description: Sunrail Quiet Zone - Special Pavement Markings

Vendor/Consultant acknowledges and agrees to the following:

The Vendor shall allow public access to all documents, papers, letters, or other material subject to the provisions of Chapter 119, Florida Statutes, and made or received by the Vendor in conjunction with this Agreement. Specifically, if the Vendor is acting on behalf of a public agency the Vendor shall:

- (1) Keep and maintain public records that ordinarily and necessarily would be required by the Department in order to perform the services being performed by the Vendor.
- (2) Provide the public with access to public records on the same terms and conditions that the Department would provide the records and at a cost that does not exceed the cost provided in chapter 119, Florida Statutes, or as otherwise provided by law.
- (3) Ensure that public records that are exempt or confidential and exempt from public records disclosure requirements are not disclosed except as authorized by law.
- (4) Meet all requirements for retaining public records and transfer, at no cost, to the Department all public records in possession of the Vendor upon termination of the contract and destroy any duplicate public records that are exempt or confidential and exempt from public records disclosure requirements. All records stored electronically must be provided to the Department in a format that is compatible with the information technology systems of the Department.

Failure by the Vendor to grant such public access shall be grounds for immediate unilateral cancellation of this Agreement by the Department. The Vendor shall promptly provide the Department with a copy of any request to inspect or copy public records in possession of the Vendor and shall promptly provide the Department a copy of the Vendor's response to each such request.

Authorized Signature: \_\_\_\_\_ Date: \_\_\_\_\_

Print: \_\_\_\_\_ Title: \_\_\_\_\_

Company/Firm: \_\_\_\_\_

STATE OF FLORIDA DEPARTMENT OF TRANSPORTATION  
**DRUG-FREE WORKPLACE PROGRAM CERTIFICATION**

375-040-18  
 PROCUREMENT  
 06/12

287.087 Preference to businesses with drug-free workplace programs. --Whenever two or more bids, proposals, or replies that are equal with respect to price, quality, and service are received by the state or by any political subdivision for the procurement of commodities or contractual services, a bid, proposal, or reply received from a business that certifies that it has implemented a drug-free workplace program shall be given preference in the award process. In order to have a drug-free workplace program, a business shall:

(1) Publish a statement notifying employees that the unlawful manufacture, distribution, dispensing, possession, or use of a controlled substance is prohibited in the workplace and specifying the actions that will be taken against employees for violations of such prohibition.

(2) Inform employees about the dangers of drug abuse in the workplace, the business's policy of maintaining a drug-free workplace, any available drug counseling, rehabilitation, and employee assistance programs, and the penalties that may be imposed upon employees for drug abuse violations.

(3) Give each employee engaged in providing the commodities or contractual services that are under bid a copy of the statement specified in subsection (1).

(4) In the statement specified in subsection (1), notify the employees that, as a condition of working on the commodities or contractual services that are under bid, the employee will abide by the terms of the statement and will notify the employer of any conviction of, or plea of guilty or nolo contendere to, any violation of Chapter 893 or of any controlled substance law of the United States or any state, for a violation occurring in the workplace no later than 5 days after such conviction.

(5) Impose a sanction on, or require the satisfactory participation in a drug abuse assistance or rehabilitation program if such is available in the employee's community by, any employee who is so convicted.

(6) Make a good faith effort to continue to maintain a drug-free workplace through implementation of this section.

**Does the individual responding to this solicitation certify that their firm has implemented a drug-free workplace program in accordance with the provision of Section 287.087, Florida Statutes, as stated above?**

YES

NO

NAME OF BUSINESS: \_\_\_\_\_

STATE OF FLORIDA DEPARTMENT OF TRANSPORTATION  
**ANTICIPATED DBE PARTICIPATION STATEMENT**

375-040-63  
PROCUREMENT  
02/07

The Prime contractor is encouraged to complete this form and submit this form with your bid/price proposal/reply. Submission of this form is not mandatory.

Procurement Number: RFP-DOT-17-18-5006-SQZ

Contractor's Name: \_\_\_\_\_

Contractor's FEID Number: \_\_\_\_\_

Is the prime contractor a Florida Department of Transportation Certified Disadvantaged Business Enterprise (DBE)?  
( yes  ) ( no  )

Expected amount of contract dollars to be subcontracted to DBE(s): \$ \_\_\_\_\_

**OR**

It is our intent to subcontract \_\_\_\_\_ % of the contract dollars to DBE(s). Listed below are the proposed DBE sub-contractors:

<u>DBE (s) Name</u>	<u>Type of Work/Specialty</u>	<u>Dollar Amount/Percentage</u>

Submitted by: \_\_\_\_\_ Title: \_\_\_\_\_  
(Type or Print)

Date: \_\_\_\_\_

Note: This information is used to track and report anticipated DBE participation in FDOT contracts. The anticipated DBE amount will not become part of the contractual terms.

STATE OF FLORIDA DEPARTMENT OF TRANSPORTATION  
**BID OPPORTUNITY LIST FOR COMMODITIES & CONTRACTUAL SERVICES**

375-040-62  
PROCUREMENT  
01/16

Prime Contractor: \_\_\_\_\_

Address/Phone Number: \_\_\_\_\_

Procurement Number: RFP-DOT-17-18-5006-SQZ

49 CFR Part 26.11 The list is intended to be a listing of all firms that are participating, or attempting to participate, on DOT-assisted contracts. The list must include all firms that bid on prime contracts, or bid or quote subcontracts and supplies materials on DOT-assisted projects, including both DBEs and non-DBEs. This list must include all subcontractors contacting you and expressing an interest in teaming with you on a specific DOT-assisted project. Prime contractors must provide information for Numbers 1, 2, 3 and 4, and should provide any information they have available on Numbers 5, 6, and 7 for themselves, and their subcontractors.

1. Federal Tax ID Number: \_\_\_\_\_  
2. Firm Name: \_\_\_\_\_  
3. Phone: \_\_\_\_\_  
4. Address: \_\_\_\_\_  
\_\_\_\_\_  
\_\_\_\_\_  
5. Year Firm Established: \_\_\_\_\_

6.  DBE  
 Non-DBE

7. Annual Gross Receipts  
 Less than \$1 million  
 Between \$1 - \$5 million  
 Between \$5 - \$10 million  
 Between \$10 - \$15 million  
 More than \$15 million

1. Federal Tax ID Number: \_\_\_\_\_  
2. Firm Name: \_\_\_\_\_  
3. Phone: \_\_\_\_\_  
4. Address: \_\_\_\_\_  
\_\_\_\_\_  
\_\_\_\_\_  
5. Year Firm Established: \_\_\_\_\_

6.  DBE  
 Non-DBE

7. Annual Gross Receipts  
 Less than \$1 million  
 Between \$1 - \$5 million  
 Between \$5 - \$10 million  
 Between \$10 - \$15 million  
 More than \$15 million

1. Federal Tax ID Number: \_\_\_\_\_  
2. Firm Name: \_\_\_\_\_  
3. Phone: \_\_\_\_\_  
4. Address: \_\_\_\_\_  
\_\_\_\_\_  
\_\_\_\_\_  
5. Year Firm Established: \_\_\_\_\_

6.  DBE  
 Non-DBE

7. Annual Gross Receipts  
 Less than \$1 million  
 Between \$1 - \$5 million  
 Between \$5 - \$10 million  
 Between \$10 - \$15 million  
 More than \$15 million

1. Federal Tax ID Number: \_\_\_\_\_  
2. Firm Name: \_\_\_\_\_  
3. Phone: \_\_\_\_\_  
4. Address: \_\_\_\_\_  
\_\_\_\_\_  
\_\_\_\_\_  
5. Year Firm Established: \_\_\_\_\_

6.  DBE  
 Non-DBE

7. Annual Gross Receipts  
 Less than \$1 million  
 Between \$1 - \$5 million  
 Between \$5 - \$10 million  
 Between \$10 - \$15 million  
 More than \$15 million

**AS APPLICABLE, PLEASE SUBMIT THIS FORM WITH YOUR:**

**BID SHEET (Invitation to Bid – ITB)  
PRICE PROPOSAL (Request for Proposal – RFP)  
REPLY (Invitation to Negotiate – ITN)**

**BID OR PROPOSAL BOND**

KNOW ALL MEN BY THESE PRESENTS: That we, \_\_\_\_\_,  
\_\_\_\_\_, as Principal (Bidder), and \_\_\_\_\_,  
\_\_\_\_\_, as Surety, are held and firmly bound unto the Florida Department of Transportation (hereinafter called the Obligee), in the full and just sum of FIVE PERCENT (5%) of the actual total of the Proposal referred to herein (do not enter figures), in lawful money of the United States of America, to be paid to the Obligee, to which payment will and truly to be made we bind ourselves, our heirs, executors, administrators, successors and assignees, jointly and severally and firmly be these presents:

WHEREAS, The said Principal is herewith submitting a proposal to the obligee for constructing or otherwise improving a road(s) and/or bridge(s) or building(s) in Orange and Seminole County, particularly known as Federal Aid Project No.(s) \_\_\_\_\_  
Financial Project No.(s) 4279856-1-72-27 Proposal ID TBD  
RFP-DOT-17-18-5006-SQZ - Sunrail Quiet Zone - Special Pavement Markings

NOW, THEREFORE, THE CONDITION OF THE ABOVE OBLIGATION IS SUCH, that if the said Principal shall execute a contract and give bond for the faithful performance thereof within the time period as stipulated by the project specifications after being notified in writing of the award of such contract to Principal, or if the Surety shall pay the Obligee the full amount of this bond, then this obligation shall be void; otherwise it shall remain in full force and effect.

SIGNED, SEALED AND DATED THIS \_\_\_\_\_ day of \_\_\_\_\_, \_\_\_\_\_

NAME OF SURETY: \_\_\_\_\_ (Affix Surety Seal)

By: \_\_\_\_\_  
Florida Licensed Insurance Agent or \_\_\_\_\_ Type/Print  
Attorney-In-Fact (Signature)

Countersigned: \_\_\_\_\_  
Florida Licensed Insurance Agent \_\_\_\_\_ Type/Print

The following Statement to be completed regarding the Florida Licensed Insurance Agent:

STATE OF \_\_\_\_\_  
COUNTY OF \_\_\_\_\_

Before me, the above signed authority, personally appeared \_\_\_\_\_, who is personally known to me or has produced \_\_\_\_\_ (type of identification) identification and is duly sworn, deposes and says that he/she is a duly authorized insurance agent properly licensed under the laws of the State of Florida to represent \_\_\_\_\_ of \_\_\_\_\_, a company authorized to make corporate Surety Bonds under the laws of Florida and acceptable as Surety on Federal Bonds and that he has signed or countersigned the above bond on their behalf.

Sworn, and subscribed to before me this \_\_\_\_\_ day of \_\_\_\_\_, \_\_\_\_\_  
\_\_\_\_\_  
(Notary Signature) Notary Public, State of \_\_\_\_\_

My commission expires: \_\_\_\_\_

NOTE: The principal bidder is not required to sign this document, as execution of Form 375-020-08 specifically binds the principal bidder to the obligations arising from this document. Failure of the principal bidder to execute Form 375-020-08, or failure of the surety to execute this document, shall result in the bid being declared nonresponsive.

NOTE: Power of Attorney showing authority of Florida Licensed Insurance Agent to sign on behalf of, and bind, surety must be furnished with this form. Affix Corporate Seal of Surety. No Bid Bond is required if the total amount of the bid is \$150,000 or less.

STATE OF FLORIDA DEPARTMENT OF TRANSPORTATION  
**PERFORMANCE BOND**

375-040-27  
PROCUREMENT  
OGC - 10/04

KNOW ALL MEN BY THESE PRESENTS: That we, \_\_\_\_\_  
(name)  
\_\_\_\_\_ (hereinafter called Vendor) of \_\_\_\_\_  
(address)

\_\_\_\_\_ and  
\_\_\_\_\_ (hereinafter called Surety) of  
(name)  
\_\_\_\_\_  
(address)

duly authorized to do business in the State of Florida, are held and firmly bound unto the State of Florida in the full and just sum of \_\_\_\_\_ Dollars (\$ \_\_\_\_\_), lawful money of the United States of America, to be paid to the Florida Department of Transportation (hereinafter called the Department), to which payment will and truly to be made we bind ourselves, our heirs, executors, administrators, successors and assigns, jointly and severally and firmly by these presents;

WHEREAS, the above Vendor has subscribed to an agreement with the Department to bear the date of \_\_\_\_\_, for contractual services agreement in connection with Sunrail Quiet Zone - Special Pavement Marking

\_\_\_\_\_ in Orange and Seminole County(ies), particularly known as \_\_\_\_\_

(hereinafter called the Agreement), upon certain terms and conditions in said Agreement more particularly mentioned; and

NOW, THEREFORE, The condition of this obligation is such that if the above Vendor in all respects will comply with the terms and conditions of said Agreement, and its obligations thereunder, including the Scope of Services, Specifications, General Conditions, Special Conditions, Bid Blank therein referred to and made a part thereof, and such alterations as may be made in said conditions and specifications, as therein provided for; and, further, if such Vendor will promptly make payment to all persons supplying labor, material, equipment and supplies, used directly or indirectly by the said Vendor or any subcontractor(s) in the prosecution of the work provided for in said Agreement, and promptly will pay all State Workers' Compensation and Unemployment Compensation taxes incurred in the performance of the said Agreement and will pay to the Department any amount in money or property, the Department may lose or be overcharged or otherwise defrauded of, by reason of any wrongful or criminal act of the Vendor, its agents, or employees, then this obligation is to be void; otherwise, to be and remain in full force and virtue in law.

WITNESS the signature of the Vendor and the signature of the Surety by \_\_\_\_\_ its

(Agent or Attorney-in-Fact, or otherwise)

with seals of said Vendor and Surety hereunto affixed this \_\_\_\_\_ day of \_\_\_\_\_.

\_\_\_\_\_  
Surety  
BY: \_\_\_\_\_  
Signature  
TITLE: \_\_\_\_\_  
Attorney-in-Fact/Agent  
(Surety Seal)

\_\_\_\_\_  
Vendor  
BY: \_\_\_\_\_  
Authorized Signature(s)  
TITLE: \_\_\_\_\_

ATTEST: \_\_\_\_\_  
Secretary/Notary

Name/Telephone #: \_\_\_\_\_  
Address: \_\_\_\_\_

BY: \_\_\_\_\_  
Signature

Note: Attach Power of Attorney showing authority of Surety's Agent or Attorney-in-Fact. This bond is not for public works contracts required by Section 25.05, Florida Statutes.



# PROPOSAL OF

(Bidder's Firm Name) (Prequalified Name, if Applicable)

(Proposing Firm's Physical Address -- City -- State -- Zip)

F.E.I.D. No. \_\_\_\_\_ Telephone No. (\_\_\_\_) \_\_\_\_\_ FAX No. (\_\_\_\_) \_\_\_\_\_

Email Address: \_\_\_\_\_

for constructing or otherwise improving a Bridge(s) and/or Section(s) of Road(s) No(s). or building(s) \_\_\_\_\_

Sunrail Quiet Zone - Special Pavement Markings

in Orange and Seminole County(ies),

\_\_\_\_\_ approximately \_\_\_\_\_ N/A

in length, and known as Federal Aid Project No(s): \_\_\_\_\_

Contract No.: \_\_\_\_\_ Financial Project No(s): 427956-1-72-27

**TO THE STATE OF FLORIDA, DEPARTMENT OF TRANSPORTATION:** Submitted \_\_\_\_\_

The Bidder, hereby declares that no person or persons, firm or corporation, other than the Bidder, is interested, in this proposal, as principals, and that this Proposal is made without collusion with any person, firm or corporation, and we have carefully and to our full satisfaction examined the Proposal forms, the Standard Specifications as amended by the Specifications Package and any Supplemental Specifications Packages, and the Plans, and that we have made a full examination of the location of the proposed work and the sources of supply of materials, and we hereby agree to furnish all necessary labor, equipment, and materials, fully understanding that the quantities shown herewith are approximate only, and that we will fully complete all necessary work in accordance with the Plans and Specifications, and the requirements under them of the Engineer, within the time limit specified in this Proposal for the following unit prices, to wit:

Was an addendum issued on this project?

Yes  No

I (We) hereby acknowledge receipt of the following Addenda issued during the bidding period.			
Addendum No.	Dated	Addendum No.	Dated



The Bidder agrees to perform all necessary work, as provided for in the contract, and if awarded the contract, to execute the Contract within 10 calendar days, excluding Saturdays, Sundays, and state holidays, after the date on which the notice of award has been given, and to fully complete all necessary work under the same within not more than 135 calendar days. It is understood and agreed that the date on which calendar days will begin to be charged to the project shall be either (1) the 30 calendar day from the date of issuance of the initial notice to begin work or (2) the date on which the Bidder actually begins work, whichever date is the earlier. The Bidder further agrees to furnish a sufficient and satisfactory bond in the sum of not less than 100 percent of the Contract price of the work as indicated by the approximate quantities shown herein.

The Bidder further agree(s) to bear the full cost of maintaining all work until final acceptance, as provided in the Contract.

If the total amount of this bid exceeds \$150,000.00, a bid guaranty of five percent (5%) of the bid, payable to the Florida Department of Transportation, must accompany this proposal. The guaranty amount shall include all bid items except construction days for A+B Bidding and lane closure for Lane Rental Bidding. If this proposal is accepted and the Bidder fails to execute the Contract under the conditions of this proposal, the bid guaranty shall be forfeited to the Department; otherwise, said guaranty is to be returned to the Bidder upon delivery of a satisfactory bond. The Florida Department of Transportation officials and employees are prohibited by law from soliciting and accepting funds or gifts from any person who has, maintains, or seeks business relations with the Department pursuant to Section 334.195, Florida Statutes.

The Bidder, hereby certifies that it has carefully examined this proposal after the same was completed, and has verified each item placed thereon. The Bidder agrees to indemnify, defend, and save harmless, the Department against any cost, damage, or expense which it may incur or be caused by any error in the Bidder's preparation of same. By signing and submitting this proposal, the Bidder certifies that no principal (which includes officers, directors, or executives) is presently debarred, suspended, proposed for debarment, declared ineligible, or voluntarily excluded from participation in this transaction by any federal department or agency.

The Bidder hereby certifies that the submitted unit price sheets are generated from the diskette provided by the STATE OF FLORIDA, DEPARTMENT OF TRANSPORTATION or accurate reproductions generated from the Department's issued Expedite Bidding System (EBS) program. If any errors have been made by the Bidder in preparing the generated sheets, the Bidder hereby consents that such errors will be applied by the Department in the manner most beneficial to the Department.

The Bidder hereby certifies and obligates its firm as "Principal (bidder)" to the attached Bid or Proposal Bond, (Form 375-020-09) as if and to the same effect as if the Bidder had affixed its signature thereon.

Section 287.134(3)(a), Florida Statutes, requires: An entity or affiliate who has been placed on the discriminatory vendor list may not submit a bid on a contract to provide any goods or services to a public entity, may not submit a bid on a contract with a public entity for the construction or repair of a public building or public work, may not submit bids on leases of real property to a public entity, may not be awarded or perform work as as contractor, supplier, subcontractor, or consultant under a contract with any public entity, and may not transact business with any public entity.

By submitting a bid, the bidder agrees to comply with section 20.055(5), Florida Statutes, and to incorporate in all subcontracts the obligation to comply with section 20.055(5) Florida Statutes.

Section 553.62, Florida Statutes, incorporates the Occupational Safety and Health Administration's (OSHA) safety standards, 29 CFR s. 1926.650 Subpart P, as the state standard. The Department of Labor and Employment Security may adopt updated or revised versions by rule. Other state or political subdivisions may also have standards that are applicable. If trench excavation will be required on the project in excess of five feet in depth, the Bidder must identify the cost of compliance with the applicable trench safety standards below. If there will be no trench excavation on the project in excess of five feet in depth, write "not applicable" below.

	Trench Safety Measure (Description)	Units of Measure	Quantity	Unit Cost	Extended Cost
A.	_____	_____	_____	_____	_____
B.	_____	_____	_____	_____	_____
C.	_____	_____	_____	_____	_____

(ATTACH SEPARATE SHEET IF NECESSARY)

TOTAL: \$ \_\_\_\_\_

If applicable, this certifies that all trench excavation done within the control of the contractor will be in accordance with all applicable standards and with the specifications, and all requirements of Sections 553.63(1)(a), 553.63(1)(b), and 553.63(1)(c), Florida Statutes.

Job No(s):

427956-1-72-27

The Bidder hereby declares that the undersigned is the person or persons responsible within the firm for the final decision as to the price(s) and amount of this bid and the Bidder further declares that:

1. The price(s) and amount of this bid have been arrived at independently, without consultation, communication, or agreement for the purpose of restricting competition with any other contractor, bidder or potential bidder.
2. Neither the price(s) nor the amount of this bid have been disclosed to any other firm or person who is a bidder or potential bidder on this project, and will not be so disclosed prior to the bid opening.
3. No attempt has been made or will be made to solicit, cause, or induce any firm or person to refrain from bidding on this project, or to submit a bid higher than the bid of this firm, or any intentionally high or non-competitive bid or other form of complementary bid.
4. The bid is made in good faith and not pursuant to any agreement or discussion with, or inducement from, any other firm or person to submit a complementary bid.
5. The Bidder has not offered or entered into a subcontract or agreement regarding the purchase of materials or services from any other firm or person, or offered, promised, or paid cash or anything of value to any other Bidder or person, whether in connection with this or any other project, in consideration for an agreement or promise by any other firm or person to refrain from bidding or to submit a complementary bid on this project.
6. The Bidder has not accepted or been promised any subcontract or agreement regarding the sale of materials or services to any other firm or person, and has not been promised or paid cash or anything of value by any other firm or person, whether in connection with this or any other project, in consideration for the firm's submitting a complementary bid, or agreeing to do so, on this project.
7. The Bidder has made a diligent inquiry of all members, officers, employees, and agents of the Bidder with responsibilities relating to the preparation, approval or submission of the firm's bid on this project and have been advised by each of them that he or she has not participated in any communication, consultation, discussion, agreement, collusion, act, or other conduct inconsistent with any of the statements and representations made in this Declaration.
8. As required by Section 337.165, Florida Statutes, the Bidder has fully informed the Florida Department of Transportation in writing of all convictions of the firm, its affiliates (as defined in Section 337.165(1)(a), Florida Statutes), and all directors, officers, and employees of the firm and its affiliates for violation of state or federal antitrust laws with respect to a public contract or for violation of any state or federal law involving fraud, bribery, collusion, conspiracy, or material misrepresentation with respect to a public contract. This includes disclosure of the names of current employees of the firm or affiliates who were convicted of contract crimes while in the employ of another company.
9. The Bidder certifies that, except as noted below, neither the firm nor any person associated therewith in the capacity of owner, partner, director, officer, principal, investigator, project director, manager, auditor, and/or position involving the administration of federal funds:
  - (a) is presently debarred, suspended, proposed for debarment, declared ineligible, or voluntarily excluded from covered transactions, as defined in 49 CFR s29.110(a), by any federal department or agency;
  - (b) has within a three-year period preceding this certification been convicted of or had a civil judgment rendered against it for: commission of fraud or a criminal offense in connection with obtaining, attempting to obtain, or performing a federal, state, or local government transaction or public contract; violation of federal or state antitrust statutes; or commission of embezzlement, theft, forgery, bribery, falsification or destruction of records, making false statements, or receiving stolen property;
  - (c) is presently indicted for or otherwise criminally or civilly charged by a federal, state, or local governmental entity with commission of any of the offenses enumerated in paragraph 9(b) of this certification; and
  - (d) has within a three-year period preceding this certification had one or more federal, state, or local government public transactions terminated for cause or default.
10. The Bidder certifies that it shall not knowingly enter into any transaction with any subcontractor, material supplier, or vendor who is debarred, suspended, declared ineligible, or voluntarily excluded from participation in this project by any federal agency unless authorized by the Florida Department of Transportation.
11. The firm certifies that the bidder is not a nonresident alien, or a foreign corporation/entity formed under the laws of a country other than the United States.
12. For projects of \$1,000,000.00 or more, the Bidder certifies that the company is not on the Scrutinized Companies that Boycott Israel List, is not engaged in a boycott of Israel; is not on the Scrutinized Companies with Activities in Sudan List or the Scrutinized Companies with Activities in the Iran Petroleum Energy Sector List.

Where the Bidder is unable to declare or certify as to any of the statements contained in the above stated paragraphs numbered (1) through (12), the Bidder has provided an explanation in the "Exceptions" portion on page 4 of 4 or by attached separate sheet.

EXCEPTIONS:

Any exception listed above will not necessarily result in denial of award, but will be considered in determining bidder responsibility. For any exception noted, indicate to whom it applies, initiating agency, and dates of agency action. Providing false information may result in criminal prosecution and/or administrative sanctions. I declare under penalty of perjury that the foregoing is true and correct.

<p><b>CORPORATION:</b></p> <p>_____</p> <p style="text-align: center;">Bidder</p> <p>Signature: _____</p> <p style="text-align: center;">President or Vice President (Circle Title)</p> <p>_____</p> <p style="text-align: center;">Print Name</p> <p>(Affix Corporate Seal)</p>	<p><b>INDIVIDUAL OR FIRM TRADING AS:</b></p> <p>_____</p> <p style="text-align: center;">Bidder</p> <p>Signature: _____</p> <p style="text-align: center;">Individual or Owner</p> <p>_____</p> <p style="text-align: center;">Print Name</p>
<p><b>PARTNERSHIP</b></p> <p>_____</p> <p style="text-align: center;">Bidder</p> <p>Signature: _____</p> <p style="text-align: center;">General Partner (Circle Title)</p> <p>_____</p> <p style="text-align: center;">Print Name</p> <p>Signature: _____</p> <p style="text-align: center;">General Partner (Circle Title)</p> <p>_____</p> <p style="text-align: center;">Print Name</p>	<p><b>JOINT VENTURE:</b></p> <p>_____</p> <p style="text-align: center;">Bidder</p> <p>Signature: _____</p> <p style="text-align: center;">Attorney-in-Fact</p> <p>_____</p> <p style="text-align: center;">Print Name</p>
<p><b>LIMITED LIABILITY COMPANY:</b></p> <p>_____</p> <p style="text-align: center;">Contractor</p> <p>Signature: _____</p> <p style="text-align: center;">Manager or Member (Circle Title)</p> <p>_____</p> <p style="text-align: center;">Print Name</p>	<p><b>CONTRACTOR:</b> _____ (Seal)</p> <p>Signature: _____</p> <p style="text-align: center;">President or Vice President (Circle Title)</p> <p><b>CONTRACTOR:</b> _____ (Seal)</p> <p>Signature: _____</p> <p style="text-align: center;">President or Vice President (Circle Title)</p> <p><b>CONTRACTOR:</b> _____ (Seal)</p> <p>Signature: _____</p> <p style="text-align: center;">President or Vice President (Circle Title)</p>

Organized and existing under the laws of the State of \_\_\_\_\_ and authorized to do business in the State of Florida, pursuant to the laws of the State of Florida, certificate of incorporation or organization or certificate of authority having been issued by the Florida Department of State.

**FAILURE TO FULLY COMPLETE AND EXECUTE THIS DOCUMENT MAY RESULT IN THE BID BEING DECLARED NONRESPONSIVE**

ATTACH BID BOND

**Job No(s):**

427956-1-72-27