



**Scope of Services for
Central Florida Regional Integrated Corridor Management
System**

Version: 1.0

Approval date: insert approval date



Scope of Services for Central Florida Integrated Corridor Management System

| DOCUMENT CONTROL PANEL | | |
|------------------------|-------------------------------------------------------------------------------------|------------|
| File Name: | | |
| File Location: | | |
| Version Number: | | |
| Name | | Date |
| Created by: | Kevin Miller/ Clay Packard/ Matt Jukes/ Joe Zingalli/ Carlton Urban/ Steve Corbin | 11/30/2016 |
| | | |
| Reviewed by: | Karen England | 12/07/2016 |
| | Karen England | 12/14/2016 |
| | Jeremy Dilmore | 12/28/2016 |
| | Karen England | 01/23/2017 |
| | Karen England | 01/25/2017 |
| | Karen England | 02/08/2017 |
| | | |
| | | |
| Modified by: | Clay Packard | 12/11/2016 |
| | Kevin Miller/ Clay Packard/ Matt Jukes/ Joe Zingalli/ Carlton Urban/Soraya Saflicki | 12/14/2016 |
| | Clay Packard | 1/25/2017 |
| | Karen England | 01/25/2017 |
| | Philip Blaiklock | 1/25/2017 |
| | Kevin Miller | 2/6/2017 |
| | Clay Packard | 2/7/2017 |
| | | |
| | | |
| Approved by: | | |

Table of Contents

| | | |
|----------|------------------------------------------------------------------------|-----------|
| 1 | PROJECT DESCRIPTION..... | 1 |
| 1.1 | CORRIDOR DESCRIPTION AND BOUNDARIES..... | 1 |
| 1.2 | CORRIDOR NETWORKS..... | 2 |
| 1.2.1 | <i>Arterial Networks</i> | 3 |
| 1.3 | CORRIDOR STAKEHOLDERS AND USERS..... | 6 |
| 1.3.1 | <i>FDOT D5</i> | 7 |
| 1.3.2 | <i>Florida’s Turnpike Enterprise</i> | 8 |
| 1.3.3 | <i>MetroPlan</i> | 8 |
| 1.3.4 | <i>Central Florida Expressway Authority</i> | 8 |
| 1.3.5 | <i>Orange County</i> | 8 |
| 1.3.6 | <i>Osceola County</i> | 9 |
| 1.3.7 | <i>Seminole County</i> | 9 |
| 1.3.8 | <i>City of Kissimmee</i> | 9 |
| 1.3.9 | <i>City of Maitland</i> | 9 |
| 1.3.10 | <i>City of Orlando</i> | 10 |
| 1.3.11 | <i>City of Winter Park</i> | 10 |
| 1.3.12 | <i>LYNX</i> | 10 |
| 1.4 | SCOPE OF THE SYSTEM..... | 10 |
| 1.5 | SYSTEM CONTEXT..... | 12 |
| 1.6 | ICMS OPERATIONS..... | 15 |
| 1.7 | SUBSYSTEM DESCRIPTIONS..... | 18 |
| 1.7.1 | <i>Data Fusion Environment Subsystem</i> | 19 |
| 1.7.2 | <i>Information Exchange Network Subsystem</i> | 21 |
| 1.7.3 | <i>Decision Support System Subsystem</i> | 40 |
| 1.8 | ASSUMPTIONS AND DEPENDENCIES..... | 47 |
| 1.8.1 | <i>System Assumptions for the ICMS Project</i> | 48 |
| 1.8.2 | <i>Technology Assumptions for the ICMS Project</i> | 48 |
| 1.8.3 | <i>Data Quality Assumptions for the DSS Subsystem</i> | 48 |
| 1.8.4 | <i>Statutory Project Management and Cyber Security Standards</i> | 48 |
| 1.9 | TECHNICAL REQUIREMENTS..... | 49 |
| 1.10 | SOFTWARE OWNERSHIP..... | 50 |
| 2 | APPLICABLE DOCUMENTS..... | 51 |
| 3 | SCOPE OF WORK..... | 52 |
| 3.1 | DEPARTMENT RESPONSIBILITIES..... | 52 |
| 3.2 | VENDOR’S GENERAL OBLIGATIONS..... | 53 |
| 3.3 | OTHER PARTICIPANTS’ OBLIGATIONS..... | 54 |
| 3.4 | OVERVIEW OF THE PROJECT STEPS..... | 54 |
| 3.5 | PROJECT TASKS..... | 55 |
| 3.5.1 | <i>Task 1 – Project Management (VENDOR)</i> | 56 |
| 3.5.2 | <i>Task 2 – System Design</i> | 61 |
| 3.5.3 | <i>Task 3 – Model Development Plan</i> | 64 |
| 3.5.4 | <i>Task 4 – System Build</i> | 65 |
| 3.5.5 | <i>Task 5 – Deployment</i> | 71 |
| 3.5.6 | <i>Task 6 – System Training</i> | 71 |
| 3.5.7 | <i>Task 7 – Operations and Maintenance, and Support</i> | 72 |
| 3.6 | SPECIAL SERVICES..... | 78 |
| 4 | VENDOR PERFORMANCE..... | 80 |
| 5 | CONTRACT DELIVERABLE REQUIREMENTS LIST..... | 83 |

List of Tables

| | |
|--------------------------------------------------------------------------------------------------|----|
| TABLE 1: CENTRAL FLORIDA REGIONAL TRANSPORTATION FACILITIES | 3 |
| TABLE 2: TRAFFIC RELATED RESPONSIBILITIES OF THE ORLANDO REGION | 7 |
| TABLE 3: RESPONSE AND REPAIR TIME SERVICE LEVEL AGREEMENT PARAMETERS AND LIQUIDATED DAMAGES..... | 77 |
| TABLE 4: LABOR CATEGORIES AND DESCRIPTIONS | 78 |
| TABLE 5: SERVICE LEVEL KEY PERFORMANCE INDICATORS AND LIQUIDATED DAMAGES | 81 |
| TABLE 6: CONTRACT DELIVERABLE REQUIREMENTS LIST..... | 83 |

List of Figures

| | |
|-------------------------------------------------------------------------------------------------------|----|
| FIGURE 1: CENTRAL FLORIDA ICMS..... | 2 |
| FIGURE 2: AAM PROJECT PHASES WITHIN THE CORRIDOR | 5 |
| FIGURE 3: SYSTEM CONTEXT DIAGRAM | 13 |
| FIGURE 4: ICMS RESPONSE PLAN PROCESS FLOW | 17 |
| FIGURE 5: ICMS PERIODIC CORRIDOR OPTIMIZATION PROCESS FLOW | 18 |
| FIGURE 6: IEN ITS DEVICE LAYERS | 22 |
| FIGURE 7: IEN EVENT LOCATIONS..... | 23 |
| FIGURE 8: IEN EVENT LIST | 23 |
| FIGURE 9: EVENT DESCRIPTION INTERFACE | 24 |
| FIGURE 10: DSS SIGNAL TIMING NOTIFICATION | 25 |
| FIGURE 11: ICM RESPONSE PLAN NOTIFICATION..... | 25 |
| FIGURE 12: OPERATIONS DASHBOARD HOME SCREEN | 26 |
| FIGURE 13: CORRIDOR OPTIMIZATION STRATEGY RECOMMENDATIONS | 28 |
| FIGURE 14: CORRIDOR OPTIMIZATION RECOMMENDATION | 29 |
| FIGURE 15: CORRIDOR OFFSET RECOMMENDATION | 30 |
| FIGURE 16: INTERSECTION PLANS RECOMMENDATION | 31 |
| FIGURE 17: HOME SCREEN WITH LIMITED-ACCESS ROADWAY INCIDENT RESPONSE PLAN NOTIFICATION BANNER..... | 32 |
| FIGURE 18: LIMITED-ACCESS ROADWAY INCIDENT - CORRIDOR DIVERSION RESPONSE PLAN DETAILS..... | 33 |
| FIGURE 19: CORRIDOR DIVERSION - FLUSH PLAN SET DETAILS | 34 |
| FIGURE 20: LIMITED-ACCESS ROADWAY INCIDENT - CORRIDOR DIVERSION RESPONSE PLAN - APPROVAL STATUS | 35 |
| FIGURE 21: HOME SCREEN WITH ARTERIAL ROADWAY INCIDENT RESPONSE PLAN NOTIFICATION BANNER..... | 36 |
| FIGURE 22: ARTERIAL ROADWAY INCIDENT RESPONSE PLANS | 37 |
| FIGURE 23: ARTERIAL ROADWAY INCIDENT RESPONSE PLAN DETAILS..... | 38 |
| FIGURE 24: SYSTEM DEVELOPMENT PROCESS | 55 |
| FIGURE 25: PRELIMINARY PROJECT GANTT CHART | 55 |

List of Acronyms and Abbreviations

| | |
|------------|------------------------------------------------------------|
| AAM | Active Arterial Management |
| API | Application Program Interface |
| ATMS | Advanced Transportation Management System |
| ATR | Automatic Traffic Recorders |
| CFX | Central Florida Expressway Authority |
| COTS | Commercial Off-the-Shelf |
| CDR | Critical Design Review |
| D5 | District 5 |
| DEPARTMENT | Florida Department of Transportation |
| DFE | Data Fusion Environment |
| DI | Data Interfaces |
| DSS | Decision Support System |
| ERE | Expert Rules Engine |
| EVE | Evaluation Engine |
| FDOT | Florida Department of Transportation |
| FTE | Florida Turnpike Enterprise |
| GUI | Graphical User Interfaces |
| I-4 | Interstate 4 |
| ICM | Integrated Corridor Management |
| ICMS | Integrated Corridor Management System |
| IEN | Information Exchange Network |
| ITS | Intelligent Transportation Systems |
| ITSIQA | Intelligent Transportation Systems Input Quality Assurance |
| KPI | Key Performance Indicator |
| LD | Liquidated Damage |
| LOS | Level of Service |
| MOE | Measure of Effectiveness |
| MPO | Metropolitan Planning Organization |
| NMS | Network Monitoring System |
| PDR | Preliminary Design Review |
| PRE | Predictive Engine |
| PSEMP | Project Systems Engineering Management Plan |
| RTMC | Regional Transportation Management Center |
| SDD | System Design Document |
| SLA | Service Level Agreement |
| SunGuide | SunGuide® Software System |

Scope of Services for Central Florida Integrated Corridor Management System

TMCTransportation Management Center
TMDD..... Traffic Management Data Dictionary
TSM&O Transportation Systems Management & Operations
USDOT..... United States Department of Transportation
WBS.....Work Breakdown Structure

1 Project Description

The Florida Department of Transportation (hereinafter DEPARTMENT or FDOT) District Five (herein after “D5”) has identified a need for software development services to design, develop, test, deploy, and support the Central Florida Regional Integrated Corridor Management System (hereinafter “ICMS”).

The DEPARTMENT is looking to enter into a contract to procure works-for-hire system design, develop, test, deploy, and support (hereinafter “PROJECT” or “CONTRACT”) for the ICMS needed as part of the Integrated Corridor Management (ICM) Program.

The term of the CONTRACT will be 5 years. The design/build portion of the PROJECT described in section 3.5 – with the exception of 3.5.1 – shall occur in the first 2 years of the CONTRACT. The operations, maintenance, and support of the system described in section ~~3.5.6~~3.5.8 shall occur in the remaining 3 years of the CONTRACT. There will also be additional services, as described in section 3.6 that can occur at any time throughout the CONTRACT.

The ICMS will consist of, but not be limited to; commercial off-the-shelf (COTS) modeling software, a custom built decision support system (DSS), and a custom built information exchange network (IEN) subsystem that includes dashboards and other user interfaces to the system, and a data fusion environment (DFE) to host data sources for both the ICMS and other external users and applications.

Additional information about the system is covered in the DSS and ATMS Software Operational Concept document.

The successfully selected software development team (hereinafter “VENDOR”) shall provide a qualified and experienced team. The VENDOR shall use an iterative software development approach described in this scope of services document.

1.1 Corridor Description and Boundaries

The ICMS is initially centered on the Interstate 4 (I-4) Corridor. The I-4 Corridor is a major east-west corridor (which travels cardinal northeast/southwest in the region). The I-4 Corridor and influence area contains a primary freeway, a commuter-rail line, transit bus service, park-and-ride lots, major regional arterial streets, toll roads, bike trails, and significant intelligent transportation systems (ITS) infrastructure. Figure 1 shows the I-4 Corridor in yellow, with the influence area shown by the dark line around the metropolitan area. However, this project will develop a modular approach to ICMS that is initially focused on the Orlando region, but will be scalable to FDOT District 5 (D5) entirely.

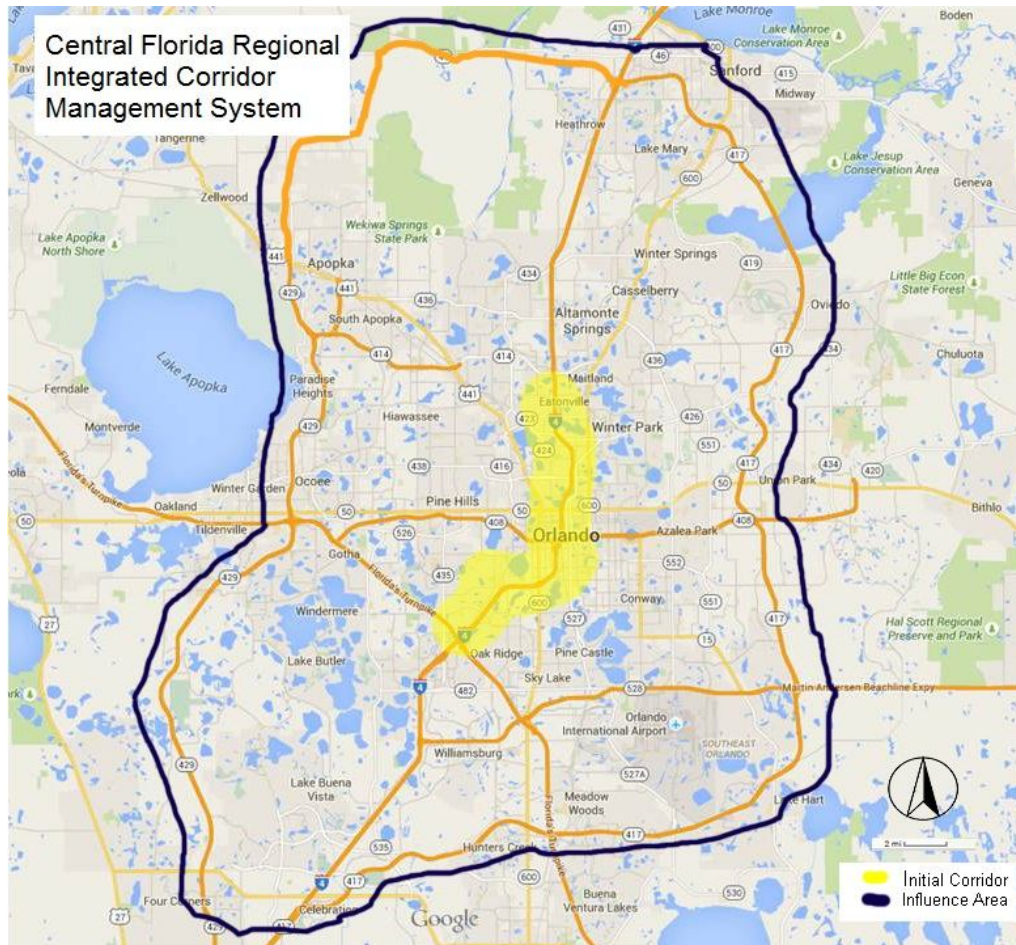

Figure 1: Central Florida ICMS

1.2 Corridor Networks

This section describes the networks contained within the corridor. A network is defined for the purposes of this PROJECT as a system of transportation infrastructure that is independent of agency or jurisdictional boundary. Table 1 provides a summary of the transportation facilities in the metropolitan area.

Table 1: Central Florida Regional Transportation Facilities

| Transportation Facility (With Corresponding Agency(ies)) within the Orlando region | Summary Total |
|------------------------------------------------------------------------------------|---------------------------------------------------------------------------------------------------------------------------------------------------------------------|
| Transportation Management Centers (TMC) | 8 TMCs (FDOT/Central Florida Expressway [CFX], City of Orlando, Orange County, Seminole County, Osceola County, LYNX, SunRail, Florida's Turnpike Enterprise [FTE]) |
| Commuter Rail Transit System | 61.5 miles (SunRail) |
| Bus Transit System | 63 Routes (LYNX) |
| Computer Controlled Traffic Signal Systems | |
| Seminole County | 380 signalized intersections |
| Orange County | 600 signalized intersections |
| Osceola County | 177 signalized intersections |
| City of Orlando | 500 signalized intersections |
| Park and Ride Lots | 12 SunRail Stations |
| I-4 | ~ 72 miles (FDOT), 21 miles of express lanes |
| Toll Roads | ~ 55 miles (FTE) ~ 109 miles(CFX) |

The Orlando region, and I-4 in particular, is a true multimodal corridor. It supports a transportation network that includes vehicular traffic on its highways, public transportation routes via bus and commuter rail, air passenger travel, and freight services creating linkages to major metropolitan population and employment and entertainment centers like International Drive, and major theme parks (i.e. Disney, Universal Studios, Sea World, etc.).

The maps showing these detour routes can be found at http://cflsmartroads.com/projects/future_projects.html.

1.2.1 Arterial Networks

The arterial network consists of several major east-west arterial streets. These major streets are typically spaced at one-mile intervals and serve as primary travel routes and potentially serve as alternate routes for traffic diverted from freeways and toll roads; however, they are also major traffic generators and need to be considered for response plan development. The key east-west arterials in the corridor are listed as follows:

- Colonial Drive (SR 50)
- Lake Mary Boulevard
- SR 536
- SR 434
- Lee Road (SR 423)

- Maitland Boulevard (SR 414)
- Aloma Avenue (SR 426)
- Sand Lake Road (SR 482)

There are also several key north-south arterials. While many of these carry significant traffic, these arterials are critical for moving traffic between the north-south routes, including for diversion purposes. They are also major traffic generators and need to be considered for response plan development. The key north-south arterials are listed as follows:

- Orange Blossom Trail (US 441)
- Kirkman Road (SR 435)
- John Young Parkway (SR 423)
- Semoran Boulevard (SR 436)
- International Drive
- Apopka Vineland Road (SR 535)
- Orange Avenue (SR 527)
- Goldenrod Road (SR 551)
- US 17/92
- Alafaya Trail (SR 434)

As part of the active arterial management (AAM) project - the traffic signals and other key ITS devices along key corridors within the region will be used to actively manage these key roadways. The map in Figure 2 shows the roadways within the ICM corridor that are a part of the AAM project.

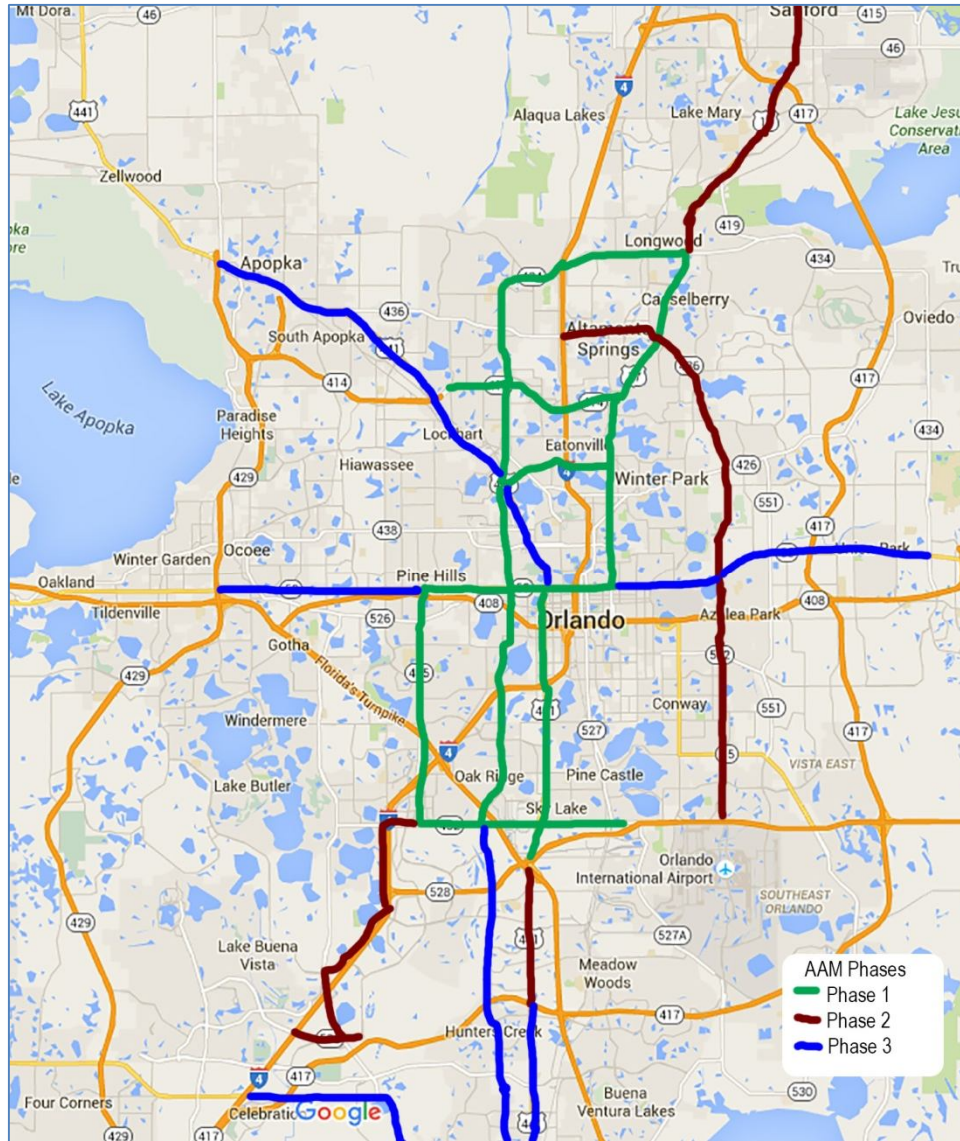

Figure 2: AAM Project Phases within the Corridor

As part of the I-4 Ultimate project, several detour routes were developed that include parts of the following east-west detour roads near I-4:

- Maitland Boulevard (SR 414)
- SR 46
- Semoran Boulevard (SR 436)
- Dirksen Drive
- SR 434
- US 17 - 92
- Lake Mary Boulevard
- Lee Road (SR 423)
- SR 46A (H.E. Thomas Blvd)
- Fairbanks Avenue (SR426)
- Princeton Street (SR 438)
- Colonial Drive (SR 50)
- Anderson Street
- W Kaley Street
- Michigan Street
- LB McLeod Road

- 33rd Street
- 35th Street
- 39th Street
- Beachline Expressway
- Millenia Boulevard
- Conroy Road
- Sand Lake Road (SR 482)
- Universal Boulevard
- SR 536
- Buena Vista Drive
- Ronald Reagan Parkway
- Osceola Polk Line Road
- US 192
- Epcot Center Road

There are also several north-south arterials involved with the detour of traffic when incidents occur on I-4. While many of these carry significant traffic, these arterials are critical for moving traffic between the north-south routes, including for diversion purposes. They are also major traffic generators and need to be considered for response plan development. The key north-south arterials are listed as follows:

- Maitland Avenue
- Longwood-Lake Mary Boulevard
- Forest City Road (SR 434)
- Rinehart Road
- Montgomery Boulevard
- International Parkway
- Poinciana Boulevard
- US 17-92
- Markham Woods Road
- John Young Parkway (SR 423)
- Wymore Road
- Orange Avenue (SR 527)
- Magnolia Avenue
- Orange Blossom Trail (SR 441)
- Garland Avenue
- N Hughey Avenue
- Rio Grande Avenue
- Orlando-Vineland Road
- Kirkman Road (SR 435)
- Turkey Lake Road
- Universal Boulevard
- World Drive
- US 27
- Lake Wilson Road

There are other transportation networks (i.e. bus, commuter rail) within the region that are further discussed in the Concept of Operations document.

1.3 Corridor Stakeholders and Users

The operating agencies located in the I-4 Corridor, all of which were involved to some extent in the development of the Concept of Operations and System Requirements, are identified in Table 2. Each agency has a designated lead staff member along with technical staff in key areas of responsibility.

Table 2 shows the current responsibilities and infrastructure that each agency currently provides to the region.

Table 2: Traffic Related Responsibilities of the Orlando Region

| Traffic-Related Roles | FDOT Central Office | FDOT D5 | FTE | MetroPlan | CFX | SunRail | Orange County | Osceola County | Seminole County | City of Kissimmee | City of Maitland | City of Orlando | City of Winter Park | Florida Highway Patrol | LYNX | Universities |
|------------------------------------------|---------------------|---------|-----|-----------|-----|---------|---------------|----------------|-----------------|-------------------|------------------|-----------------|---------------------|------------------------|------|--------------|
| Police | | | | | | | | | | | X | X | | X | | |
| Fire | | | | | | | X | X | X | X | X | X | X | | | |
| Emergency Services | | | | | | | X | X | X | X | X | X | X | X | | |
| Road Ranger/ Courtesy Patrol | | X | X | | X | | | | | | | | | | | |
| Traffic Signal System | | X | | | | | X | X | X | X | X | X | X | | | |
| Detectors | | X | X | | X | | X | X | X | X | X | X | X | | | |
| Dynamic Message Sign | | X | X | | X | | X | X | X | X | X | X | X | | | |
| Public Works | | | | | | | X | X | X | X | X | X | X | | | |
| Closed-circuit Television | | X | X | | X | | X | X | X | X | X | X | X | | | |
| Electronic Toll /Fare /Parking equipment | | | X | | X | X | | | | | | X | | | X | |
| Transit – Bus/ Commuter Rail | | | | | | X | | | | | | | | | X | |
| Parking Management | | | | | | | | | | | | X | | | | |
| Maintenance/ Construction | | X | X | | X | X | X | X | X | X | X | X | X | | X | |
| Data Warehouse/ Analytics | X | X | | X | | | | | | | | | | | | X |
| Modeling | | X | X | X | X | | | | | | | | | | | |
| Internet Traveler Information | X | X | X | | X | X | | | | | | | | | X | |
| Congestion Pricing | | X | X | | | | | | | | | | | | | |

1.3.1 FDOT D5

FDOT D5 operates and maintains the interstates, US highways, and state highways within the region. The regional transportation management center (RTMC) serves as the

command post that monitors and manages D5 technologies to provide motorists with reliable traveler information. The RTMC coordinates with incident responders in Brevard, Flagler, Lake, Marion, Orange, Osceola, Seminole, Sumter, and Volusia Counties to maintain the information flow throughout the District.

In addition, the RTMC is the home of FDOT D5's active arterial management project, which manages the traffic signals and other key ITS devices along key corridors within the region and will be used to actively manage the arterial corridors.

1.3.2 Florida's Turnpike Enterprise

FTE is a business unit of the DEPARTMENT, employing private sector business practices to operate its 483-mile system of limited-access toll highways across Florida. The FTE system includes the Mainline from Miami to Central Florida as well as the Homestead Extension, the Sawgrass Expressway, the Seminole Expressway, the Beachline Expressway, the Southern Connector Extension of the Central Florida GreeneWay, Veterans Expressway, the Suncoast Parkway, the Polk Parkway, the Western Beltway and the I-4 Connector. On average, 1.8 million motorists use Florida's Turnpike each day.

1.3.3 MetroPlan

Also known as the Orlando Urbanized Area Metropolitan Planning Organization (MPO), MetroPlan Orlando is one of 26 MPOs in the State of Florida, and it was one of the first multi-county MPOs in the state. MetroPlan Orlando is the MPO for Orange, Osceola, and Seminole counties, and the cities within those counties, including the City of Orlando, City of Winter Park, City of Maitland, and City of Kissimmee – which makes up the Orlando Urbanized Area. As a regional MPO, MetroPlan Orlando provides the forum for local elected officials, their staff, citizens, and industry experts to work together to improve transportation in Central Florida. A key responsibility under federal law is the development of a Long-Range Transportation Plan for the region.

1.3.4 Central Florida Expressway Authority

CFX is responsible for the construction, maintenance, and operation of a 109-mile limited-access expressway system. It may also acquire, construct, and equip rapid transit, trams, and fixed guideways within its rights-of-way. CFX's system includes SR 408 (Spessard Holland East-West Expressway), SR 528 (Martin Andersen Beachline Expressway), SR 417 (Central Florida GreeneWay), SR 429 (Daniel Webster Western Beltway), SR 414 (John Land Apopka Expressway), and State Road 451. CFX's jurisdiction includes Orange, Lake, Osceola, and Seminole Counties.

1.3.5 Orange County

Orange County has a population of 1,145,956 according to the 2010 United States Census, making it the fifth-most populous county in Florida. Located in Central Florida,

Orange County includes the City of Orlando and a dozen other incorporated municipalities. Orange County uses Siemens Tactics Software and Eagle Traffic Signal Controllers for their signal system.

1.3.6 Osceola County

As of the 2010 census, the population of Osceola County was 268,685. Its county seat is Kissimmee. The Traffic Engineering Department is a part of the Public Works Division and conducts traffic studies, analyzes crash data, performs signal design reviews, manages the annual traffic count program, issues signal warrants, performs special event reviews, and participates in the development review process. The Traffic Operations Department installs and operates county signs, signals, roadway lighting, striping, and pavement markings. Osceola County uses Econolite Traffic Signal Controllers and Econolite Centracs software.

1.3.7 Seminole County

As of the 2010 census, the population of Seminole County was 422,718. It is the smallest county according to land size in the state. The county seat is Sanford. The transportation system of Seminole County brings people and goods into the county, accommodates traffic passing through the county, and provides the mobility and accessibility that allows residents to participate in the community's social and economic activities. Historically, the county's transportation system was dominated by a single transportation mode – the private automobile. Public transit played a relatively minor role, and walking and biking played purely recreational roles. There are approximately 2,320 centerline miles of roadways in Seminole County. These roadways have been assigned to the State Highway System, the County Road System and the City Street Systems based on the functional classification of individual roadway segments as determined by FDOT. Seminole County uses Naztec controllers with ATMS.Now software.

1.3.8 City of Kissimmee

Kissimmee is a suburban city in Osceola County, Florida. As of the census, the population was 59,682. The City of Kissimmee Traffic Division is responsible for the maintenance of signalized intersections for the City of Kissimmee and Osceola County. The City of Kissimmee uses Econolite Traffic Signal Controllers and Econolite Centracs software.

1.3.9 City of Maitland

Maitland is a suburban city in Orange County, Florida, part of the Greater Metro Orlando area. The population was 15,751 at the 2010 census. The Maitland Transportation Engineer is responsible for transportation-related movements in the city with regard to automobiles, pedestrians, bicycles/bike paths, rail systems, and bus routes. The objective is to coordinate these facilities into an integrated system that best serves the citizens of Maitland. The City of Maitland uses Eagle Traffic Signal Controllers.

1.3.10 City of Orlando

In 2010, Orlando had a city-proper population of 238,300, making it the 77th largest city in the United States, the fifth largest city in Florida, and the state's largest inland city. Orlando is also known as "The Theme Park Capital of the World" and "City Beautiful." In 2014, tourist attractions and events drew more than 62 million visitors. The Orlando International Airport is the 13th busiest airport in the United States, and the 29th busiest in the world.

The City of Orlando Traffic Signal Maintenance is responsible for the maintenance of 500 signalized Intersections, 21 school zone flashers, and 21 warning flasher locations. The Operations Center services the traffic signals in the city 24 hours per day, 7 days per week. The City of Orlando uses Naztec controllers with ATMS.Now software.

1.3.11 City of Winter Park

Winter Park is a suburban city in Orange County, Florida. The population was 27,852 at the 2010 census. The Engineering Division within the Public Works Department manages all work in the city's rights-of-way including road design, parking and site improvements for city structures, traffic analysis and control, signal analysis and design, coordination and implementation of streetlights, administration of the city's streetlight, brick street and sidewalk policies, survey and mapping, inspection of construction activities, permitting of right-of-way uses, and utility connections. The City of Winter Park uses Eagle Traffic Signal Controllers.

1.3.12 LYNX

The Central Florida Regional Transportation Authority, known as LYNX, provides bus transit service for Orange, Seminole, and Osceola Counties. This includes 63 local bus routes including the LYMMO downtown circulator, FastLink commuter service, Xpress service from Orlando to Volusia and Lake Counties, and ACCESS LYNX, which serves disabled customers. SunRail train service is a partner with LYNX.

The LYNX Operations Center is at 2500 Lynx Lane in Orlando near John Young Parkway and Princeton Street.

1.4 Scope of the System

The Central Florida Regional ICMS is an essential system for the operating agencies within the region to implement coordinated strategies to meet transportation performance measures and in response to recurring congestion and planned and unplanned traffic events causing congestion and/or delay. The ICMS will become the collective knowledge resource to select appropriate response plans either through an automated or human process and determine potential corridor benefits of proposed response plans. The ICMS is comprised of three main systems: 1) DFE, 2) IEN, and 3) DSS.

The DFE will host a variety of data sets used and produced by the ICMS and other external systems. Data interfaces (DI) will be developed to receive Central Florida transportation network data from various transportation data providers into the DFE. Application program interface (API) specifications will be provided for the majority of interfaces. However, if a new data source is found to be necessary, the VENDOR may be required to develop the data interface for that source and will include additional APIs as part of a Special Projects scope outside the base scope. The DFE will also serve other D5 transportation operations beyond the needs of the ICMS.

The IEN provides graphical user interfaces (GUI) for agencies to view the entire data set of transportation information on a single GUI and interact with the system including invoking response plans. The IEN also provides notifications through text, emails, and mobile applications to notify stakeholder agencies of events and response plan actions needed.

The DSS will be developed to provide a system to review and evaluate the current and predicted conditions of the Central Florida transportation network in order to help operators make smart decisions in managing both recurring and non-recurring congestion conditions. Components to the DSS will include an Expert Rules Engine (ERE), a Predictive Engine (PRE), and an Evaluation Engine (EVE) that will build and select response plans to be evaluated, model the predicted outcomes of the selected response plans, evaluate and score the plans, coordinate with operators and local agency maintainers through the IEN, and invoke the approved response plan actions through the SunGuide® software system (SunGuide). Once the system has deployed a response plan to SunGuide, the DSS will continue to monitor event status for changes and until the congestion has been alleviated so response plans can be modified or deactivated. The core responsibilities of the DSS are as follows:

- a. Monitor, evaluate, and respond to reoccurring congestion along the arterial network.
- b. Evaluate and respond to non-recurring congestion on I-4 within the identified network.
- c. Evaluate and respond to non-recurring congestion on arterial roadways within the identified network.

The main functionality of the ICMS is to:

- Receive live and historical data from traffic and transportation-related systems and operations in the region;
- Provide the current status of devices and performance of roadway and transit network within the region of interest;
- Analyze infrastructure status data to determine the availability of infrastructure components and/or systems to use in corridor improvement strategies and response plans in the region;

- Analyze collected data to determine transportation performance, potential corridor improvement strategies, and responses to traffic events and congestion. Strategies and responses will include, but are not limited to:
 - Coordinated timing plan for central traffic signal software;
 - Metering state and rates for ramp meters;
 - Hard shoulder running;
 - Dynamic messaging for diverting traffic;
 - Disable pricing on managed lanes;
 - Responder dispatch and coordination; and
 - Transit rerouting and bus bridging.
- Evaluate the potential benefit of implementing corridor improvement strategies and associated response plans through simulation in real-time and offline;
- Evaluate the impact of enacted corridor improvement strategies and associated response plans in real-time and offline;
- Provide stakeholders with the capability to provide and receive transportation-related data; and
- Present stakeholders with transportation-related analysis, and corridor improvement and response plan recommendations in an interactive real-time manner.
- Some areas of the system were not specified in the requirements. These areas are opportunities to add value as innovated approaches and solutions to be included in the technical proposal and final scope. They include the following:
 - Determine offsets during period corridor optimization described in section 1.7.3,
 - Determine cycle length during period corridor optimization described in section 1.7.3,
 - Account for pedestrian and bus signal phases in the signal optimization algorithm described in section 1.7.3,
 - Integration with existing adaptive signal control systems, such as Insync or Synchro, in the signal optimization algorithm described in section 1.7.3,
 - Determine the master signal when an arterial incident is detected and the signal network is being dynamically determined described in section 1.7.3, and
 - Determine how connected vehicles, infrastructure, and their data will be integrated into the DFE and TSM&O operations when there is sufficient market penetration and we can get data directly from vehicles and interact directly with most or all vehicles.

1.5 System Context

The system context diagram in Figure 3 shows a high-level conceptual framework of the FDOT D5 Operations, the DFE, and the integrated devices and data sources with D5 and partner agencies. The PROJECT consists of the ICMS Software Application, the IEN, and

Scope of Services for Central Florida Integrated Corridor Management System

the supporting DFE. The ICMS is a data processing system integrated into other D5 transportation systems management and operations (TSM&O) operations as well as the DFE shown in Figure 3. The DFE is integrated with data sets, data streams in motion, and user applications.

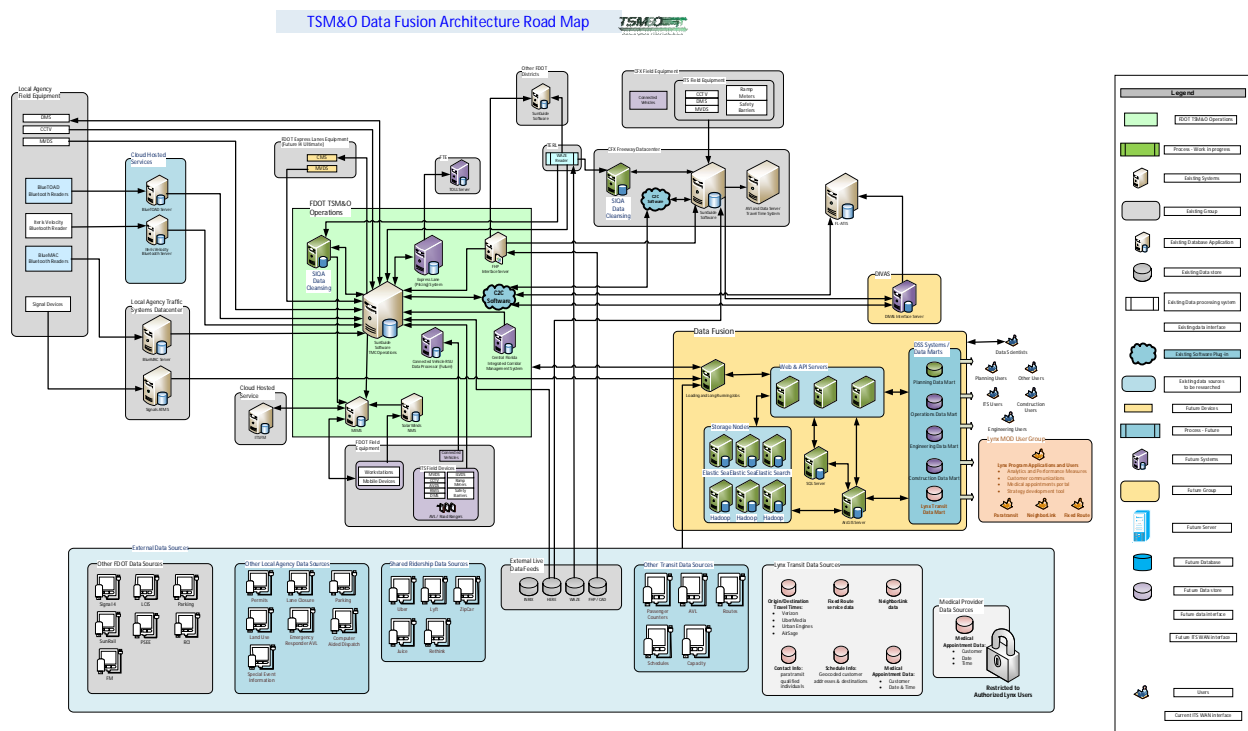

Figure 3: System Context Diagram

DI, as discussed in the sections below, interface with both data providers and data consumers. DIs can be implemented as data extractors to pull data into the DFE, or APIs to provide access to data in the DFE to other ICMS subsystems and components, and external users and applications.

The D5 TSM&O Operations, DFE, DIs, and other integrated devices and data sets are in currently and continually various states of existing operations, ongoing development, and legacy system support. The ICMS will be developed in a way that preserves this growing ecosystem of systems. Existing operations will not be interrupted. Early designs, prototypes, and implementations of systems to be implemented by this PROJECT will be provided to support this PROJECT's design and development, but not necessarily required to be used. There are other systems to be interfaced or integrated with the ICMS, but not developed by the ICMS PROJECT.

At the heart of the TSM&O data operations architecture is the group of systems performing real-time operations. This includes the following systems:

- Existing systems physically deployed in the D5 data center:
 - SunGuide, performing the primary command and control;

- Maintenance and Inventory Module Subsystem, providing ITS asset maintenance management;
 - SolarWinds network management system; and
 - Florida Highway Patrol Interface Server providing all of the state's SunGuide deployments with Florida Highway Patrol computer-aided dispatch data.
- Systems under development, to be deployed in the D5 data center:
 - Intelligent Systems Input Quality Assurance (ITSIQA) is a project that will perform transportation sensor data quality assurance and fusion onto a common base map.
 - Intersection Movement Counts is a project to retrieve turning movement counts for intersections from the traffic signal controllers.
 - Transit Signal Priority is a project where a bus behind schedule can invoke a priority to the traffic signal that the bus is approaching.
 - Future systems to be developed including an express lanes pricing system, a connected vehicle roadside unit data processing system, a mixed mode routing engine, and this ICMS. These systems will all benefit from a centralized environment from which real-time and archived transportation related data can be obtained.
 - Existing cloud-hosted systems used by TSM&O Data operations:
 - ITS Freeway Management system providing statewide inventory of ITS assets;
 - BlueMAC Server, BlueTOAD Server, and Iteris Velocity Server proving data collection and processing from Bluetooth reader; and
 - Signal advanced transportation management system (ATMS) central software systems providing a central interface to an agency's network of traffic signal controllers.

The DSS will be another application in the operations systems group. Also hosted by D5's data center will be the DFE, which is, in a sense, also a D5 TSM&O system. However, it is separated in Figure 3 to show more details of the components in the DFE and to delineate it from an operations application to the paradigm shift of data storage and access. Data marts, or APIs, provide the users and applications with access to data stored within the storage components of the DFE. They provide a consistent interface to a cataloged set of data sources.

With the DFE in place, as more applications are created and enhanced, they will migrate to relying on the DFE as a central data hub. Applications will retrieve the data they need to process and provide processed data back into the DFE in three components, creating a pattern of separate DIs, data processors, and APIs as a design pattern.

More details of an initial documentation of the environment and plan for the future DFE-centric environment can be found in the supporting materials at http://cflsmartroads.com/projects/future_projects.html.

1.6 ICMS Operations

The TSM&O regional traffic optimization operations include a network of agencies working together to improve mobility of the transportation network. The ICMS operations supports the TSM&O operations, and includes the following concurrent processes:

- **Data Collection, Cleansing, Fusion, Archiving, and Interfacing** – this operational process supports ICMS as well as other users and applications with transportation information. Activities in this environment include retrieving data from real-time devices and systems, performance quality analysis and transformation of the data to a more usable state, providing the data streams in real-time to other applications, providing access to archive data, and supporting deep analytics to discover additional value, insights, and further decision-making and performance evaluation support.
- **Traffic Incident Response on Limited-Access Facilities** – this operational process monitors the Event Management Subsystem of the SunGuide software for incidents on limited-access facilities, determines an appropriate adjacent corridor flush strategy and other strategies pre-defined by FDOT as an incident response plan, determines the measure of effectiveness of the response plan using a mesoscopic simulation of a reduced network, coordinates with FDOT and/or local agency maintainers for approval, invokes the response plan through the SunGuide software, continues to monitor the incident and environment conditions, makes adjustments to the response plan, and finally deactivates the response plan.
- **Traffic Incident Response on Arterial Facilities** – this operational process monitors the turning movement counts, the signal performance measures data, and ITSQA output for an increase in queue length and/or travel time over a configurable percentage of historical value, determines a better optimized corridor signal timing plan set from existing plans, determines the measure of effectiveness of the signal timing plan set using a mesoscopic simulation of a reduced network, coordinates with FDOT and/or local agency maintainers for approval, invokes the response plan, continues to monitor the incident and environment conditions, makes adjustments to the response plan, and finally deactivates the response plan.
- **Periodic Signal Timing Optimization** – this offline process optimizes the network by considering all 5-minute interval's saturation rates for each movement of each intersection within a corridor or a signal in isolation, groups the intervals into contiguous intervals based on similarity of their saturation rates, clusters similar groups of contiguous intervals, calculates new optimal timing plans for the cluster of contiguous groups, calculates the percent improvement and applicability over the plans currently in use, presents optimal plans and metrics and related data to the signal timing engineer for review and timing plan implementation. The engineer can view the optimal plans and related data, make adjustments and new plans, request reduced mesoscopic simulations, and provide signed and sealed plans for approval and implementation.

The system context diagram in Figure 3 shows a high-level conceptual flow of the ICMS operations and process in meeting the core responsibilities of the DSS. The following are the detailed steps shown in the figure:

1. External data sources and event data sources are collected, if needed, then formatted and stored in the DFE.
2. The ERE polls the DFE continuously for the latest status and event information. The ERE analyzes the latest data to perform the following four subtasks:
 - a. Check for any new or updated event data for SunGuide freeway related events;
 - b. Check for any new or updated event data for arterial related events (Local Events);
 - c. Analyze signals to check for level of service (LOS) triggers including the following:
 - i. Deviation in queue length from expected value
 - ii. Deviation in turning movement counts from expected values
 - d. Perform periodic, offline optimization of traffic signals based on a demand clustering and clumping algorithm.
3. Depending on the results of the previous step, the ERE can perform one or a combination of following functions:
 - a. For freeway or arterial related events, the ERE will evaluate the severity and, based on the rules, determine the need for a response plan evaluation and if needed will select the most appropriate or applicable response plans from the Response Plan Repository within the DFE for evaluation and send the request for the mesoscopic predictive simulation analysis; this function will repeat throughout the life of the event until the event has cleared and the mesoscopic predictive simulation analysis confirms that any event response plans related to that incident can be reverted back to normal operations.
 - b. For signal LOS, queue length, or travel time deviation alarms, or for periodic offline optimization, the ERE identifies the adjacent signals to be analyzed as a group and sends this selected group to the PRE for optimization using the deterministic model and evaluation within the predictive traffic simulation model.
4. The deterministic model, when requested, builds a current corridor network for the requested intersections and optimizes the timing plans and offsets using the deterministic model to reduce the delays and improve the LOS. New timing plans may be sent to the mesoscopic simulation to be evaluated.
5. The mesoscopic traffic simulation model gets the request from the ERE and/or the deterministic model and builds each of the requested models, including the Do Nothing. The models are built using the status data from the DFE and the current date and time information. Simulations are run in parallel and the data is sent to the EVE and the DFE.
6. The EVE calculates the score for each Response Plan or the benefit for any suggested signal timing optimization changes by calculating the measures of effectiveness (MOE) and evaluating the recommended benefits of the response scenarios versus the Do Nothing scenario.

7. If the benefit or score of the best plan is sufficiently high enough, the EVE will send the recommendations through the IEN to the ICM operator/manager.
8. The manager reviews the plan and makes the final decision on its applicability to the current conditions. Upon approving the plan, the ICM operator/manager sends the requested controls through the IEN to the various implicated agencies.
9. Individual agencies approve or deny the requests and confirm that all actions were successful, providing necessary changes to reflect non-performed actions (assuming the initial request was approved).
10. After implementation or if no plan or change is recommended, the ERE will monitor the current conditions and, depending on said conditions, will determine if the event should be re-evaluated or terminated. Upon termination, response plan actions are cancelled and devices are returned to typical time of day operations. If re-evaluation is warranted ERE starts at step 2 again and goes through the steps to prepare the models for evaluations.

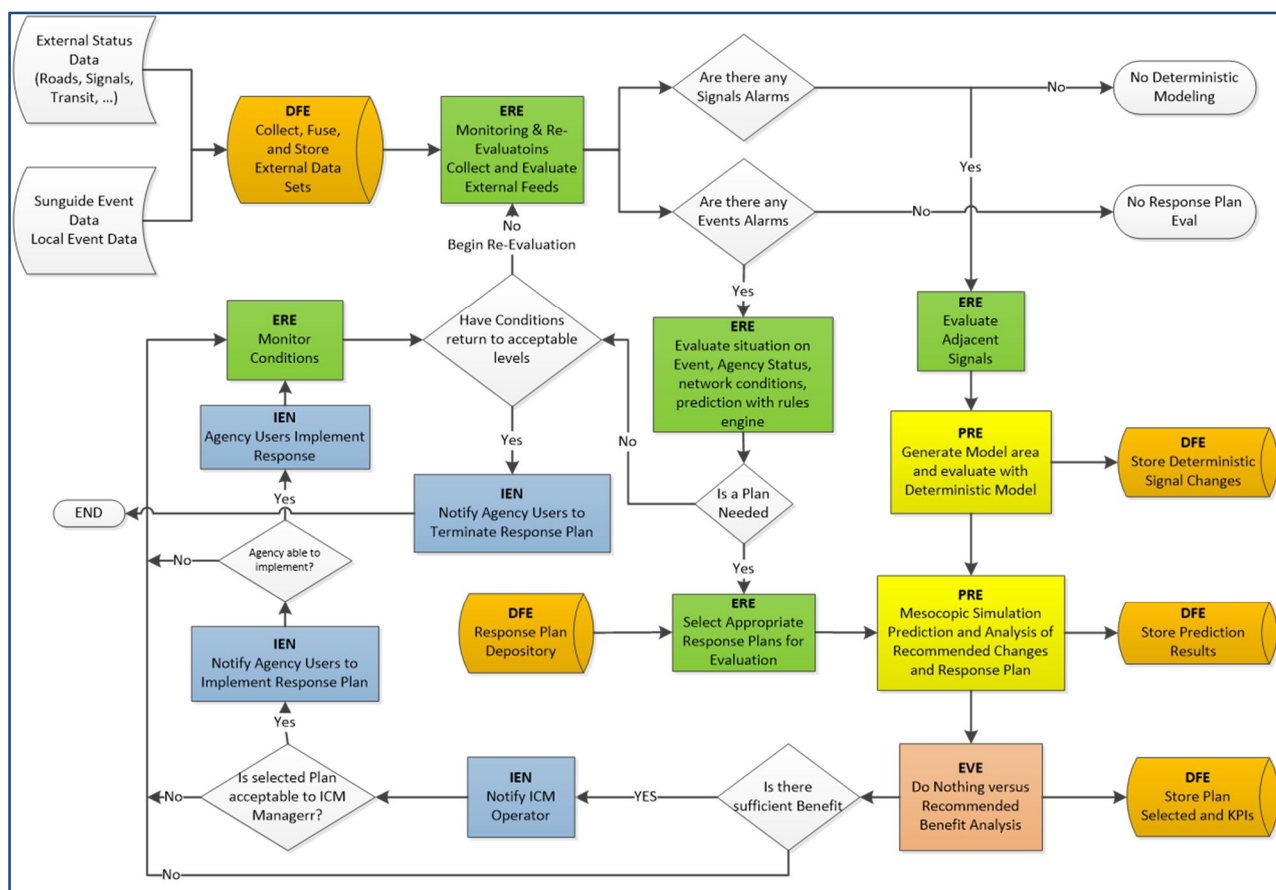

Figure 4: ICMS Response Plan Process Flow

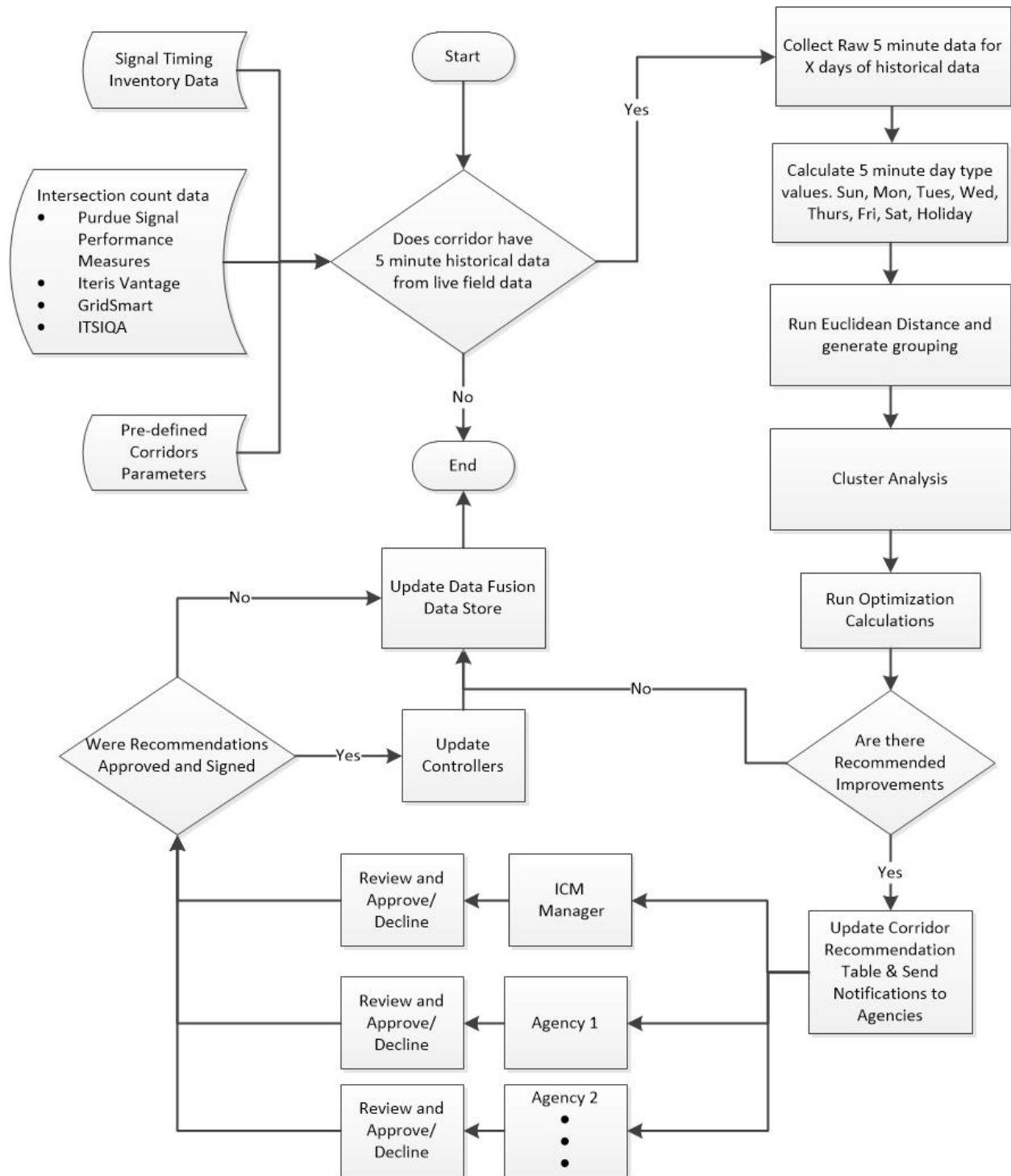

Figure 5: ICMS Periodic Corridor Optimization Process Flow

1.7 Subsystem Descriptions

The following sub-sections provide a high-level description of the ICMS subsystems.

1.7.1 Data Fusion Environment Subsystem

The ICMS will collect and share data sets and data streams in motion from a wide variety of data sources for use by other ICMS subsystems and other external users and stakeholders. Work has already been done to develop a prototype of this system. The ICMS will build upon this work to provide a robust production system that meets the requirements of other subsystem and other external users.

Data collected into the DFE subsystem will come from a variety of sources. Details of a sampling of these data sources can be found in the draft data dictionary documents, and the TSM&O Data and Systems Inventory. The DFE will be comprised of the following components:

- DIs that extract data from sources,
- Various data warehousing components to store the data,
- Processing components to process the data and perform data analytics, and
- API for users and other applications to access the data.

The DIs will extract data from these sources, validate it, transform it into a suitable format for retrieval and analysis, and store the data into one of the data warehousing components. The data warehousing components consist of traditional data warehousing technologies such as SQL Server relational database management system, an ArcGIS Data Store, and unstructured data storage components. The DEPARTMENT is piloting open source data warehousing components for the underlying unstructured data store, and including COTS components for other specialty data storage and processing functionality including an ArcGIS Data Store and an SQL Server transactional database management system.

The DFE represents a paradigm shift from silos of information and applications to a shared data environment that synergizes data streams and data sources not previously integrated to support data analytics of value not previously captured. The DFE shall support other ICMS subsystems as well as external analytics and applications.

The DFE will extract, transform, and load traditional structured and transactional data, unstructured data, and geographical and time-based data in a way to support efficient search, retrieval, and analysis. The DFE subsystem will provide API to the data sets, data streams, and derived data sets and data streams based on a processed output of other data sets and data streams. An administrative application will be used to manage the datasets including a catalog also accessible via an API, and implement a usage and access policy to secure the data. The D5 environment as an existing Lightweight Directory Access Protocol environment that can be used to define users, groups, and permissions. The DFE will also support data science research for data scientists to discover new analytical insights on the data without risk or impact to other operations and applications.

The DFE subsystem will be designed to label and store multiple versions of a data source to accommodate simulated data to facilitate simulation and testing for the integration, test,

maintenance, and training activities of this project while also maintaining live, production operations.

The current pilot for this utilizes SQL Server Enterprise, extensible set of servers running Hadoop on HDFS, and an extensible set of servers running Elastic Search. The VENDOR shall evaluate the current environment and consider including it in the proposed design and implementation for the production DFE subsystem as a part of this PROJECT in order to meet the PROJECT requirements.

The DEPARTMENT has developed an action plan for a pilot, or sandbox, of the DFE that can be used as a starting point of the production DFE subsystem. More information on the pilot DFE Sandbox and additional notes can be found online at http://cflsmartroads.com/projects/future_projects.html.

The data sources collected by the ICMS software will include several types of data, both static and dynamic. The static data includes data that will not change very often, if at all, during the development and deployment of this project and its on-going operation. These types of data include roadway links and nodes, SunRail routes and stations, LYNX bus routes and stations, location of existing infrastructure, and similar items. Dynamic data includes things that have an impact on the current operations, such as real-time traffic conditions, current location of bus and train vehicles, and items that change rapidly and will assist the operators of the network in making decisions. Both of these data types will be important to the operations of the region, and specifically the I-4 corridor, and will drive the response selection of the DSS.

Each stakeholder has information and data flows that will be needed during the operation of the project. As part of the requirements definition, each data type and data source was identified to ensure that the necessary data is available for the systems being developed and deployed.

These data elements include, but are not limited to the following: incidents, construction, special events information, performance data (speed, volume, occupancy, travel time, status, and weather), and request/response interaction for the DSS response plan distribution. Incidents, construction, and special events in the system will be entered through SunGuide, and made available to the DSS through the DFE subsystem. Performance data is provided by the various agencies and new field infrastructure systems, including existing DEPARTMENT SunGuide, CFX and FTE SunGuide, LYNX bus automatic vehicle location systems; and parking management and weather information systems. A list of data sets currently identified that shall at a minimum be included in the DFE, including a reference to where the protocol or their interfaces can be found is in the Exhibit B, Minimum Technical Requirements. At the time of the development of this scope, not all data sets have been fully documented, but there is an ongoing effort to do so as part of the other existing TSM&O data initiatives projects, which can be expected to be provided.

1.7.2 Information Exchange Network Subsystem

The purpose of the IEN is to provide the GUI needed for a web-based information exchange tool for the stakeholder agencies to share information and manage incidents, construction, and special event information. The IEN GUI is the presentation layer for the DSS in simplest terms. It is anticipated that the IEN will provide the agency users and stakeholders with a graphical tool to manage and monitor the status of their transportation networks, allowing full event management capability as well as allowing the users to make informed decisions regarding the management of their transportation infrastructure.

The main functionality of the IEN will include the following:

- View current status and performance of roadway and transit networks and devices within the corridor;
- Create and/or respond to traffic incidents, construction, special events, or planned events from detection to resolution;
- Monitor the status of recommended and implemented response plans from plan recommendation to incident resolution; and
- Review and respond to prioritized list of corridor improvement strategies including suggested timing plans to be implemented.

1.7.2.1.1 IEN GUI Overview

The IEN interface will allow all stakeholders and users to view and interact with various data provided by the DFE and DSS appropriate for their role as a stakeholder or user. The following user roles will be supported:

- General Public
- Local Agency Signal Timing Engineer
- ICM Corridor Manager

The general public will be provided a high-level view of the system with the ability to drill down to more specific locations. The general public will not need user accounts, but cookies should be used to attempt to remember any display preferences the user might have made including the area on the map the user zoomed and panned to, the layers on the map the user selected to be displayed, and any other minor display preferences the user may have selected.

D5 has already done work to develop a set of requirements and graphical mock-ups of a proposed prototype of a portion of this GUI as described and depicted in the following figures, and as detailed in the Project Delivery Methodology of the FDOT District 5 AAM Dashboard, Version 1.0, Revision Date: 09/30/2016, Attachment A (Software Requirement Specifications) and Attachment B (System Requirements). The PROJECT will build upon this work to provide a robust production system that meets the requirements of the IEN.

The IEN will provide the user the ability to view various layers on a map that are geo-located, for instance [Figure 6](#) provides the map with speed data (detectors), traffic signals, dynamic message signs. The interface would allow the user to turn on and off the various layers and then select the icons to see additional information regarding that asset.

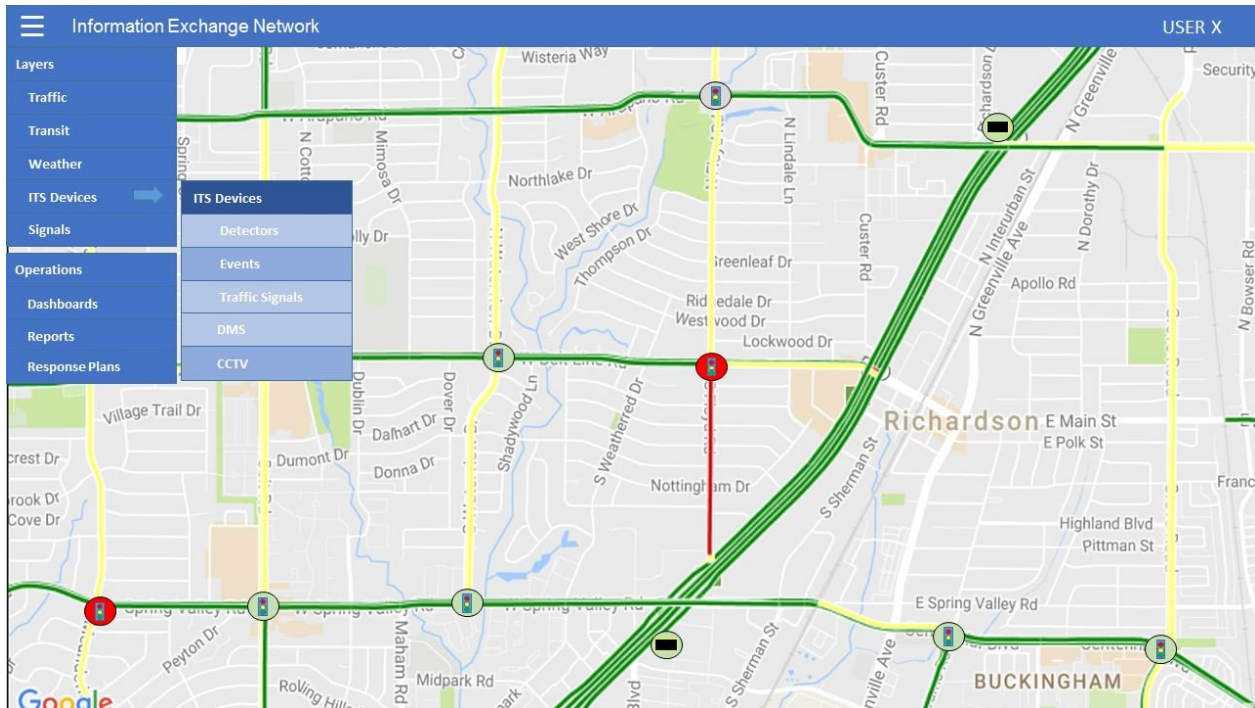

Figure 6: IEN ITS Device Layers

[Figure 7](#) provides current events in the transportation network; each type of event has a color-coded icon for incidents (accidents), construction (current and planned), and special events (current and planned).

Scope of Services for Central Florida Integrated Corridor Management System

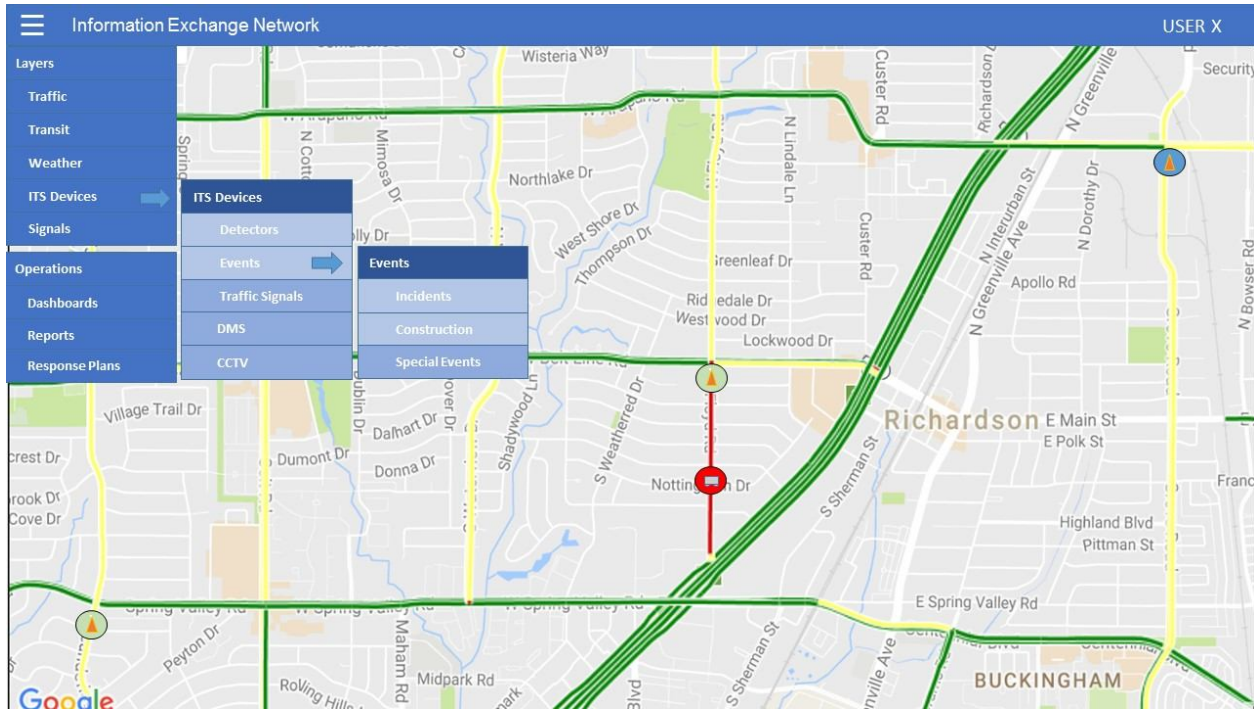

Figure 7: IEN Event Locations

For events within the DFE, the IEN will display a list of the events that are sortable by event type, event ID, location, etc. ~~Figure 8~~ ~~Figure 8~~ displays the event list and allows the user to select individual events, and view and update information (~~Figure 9~~ ~~Figure 9~~).

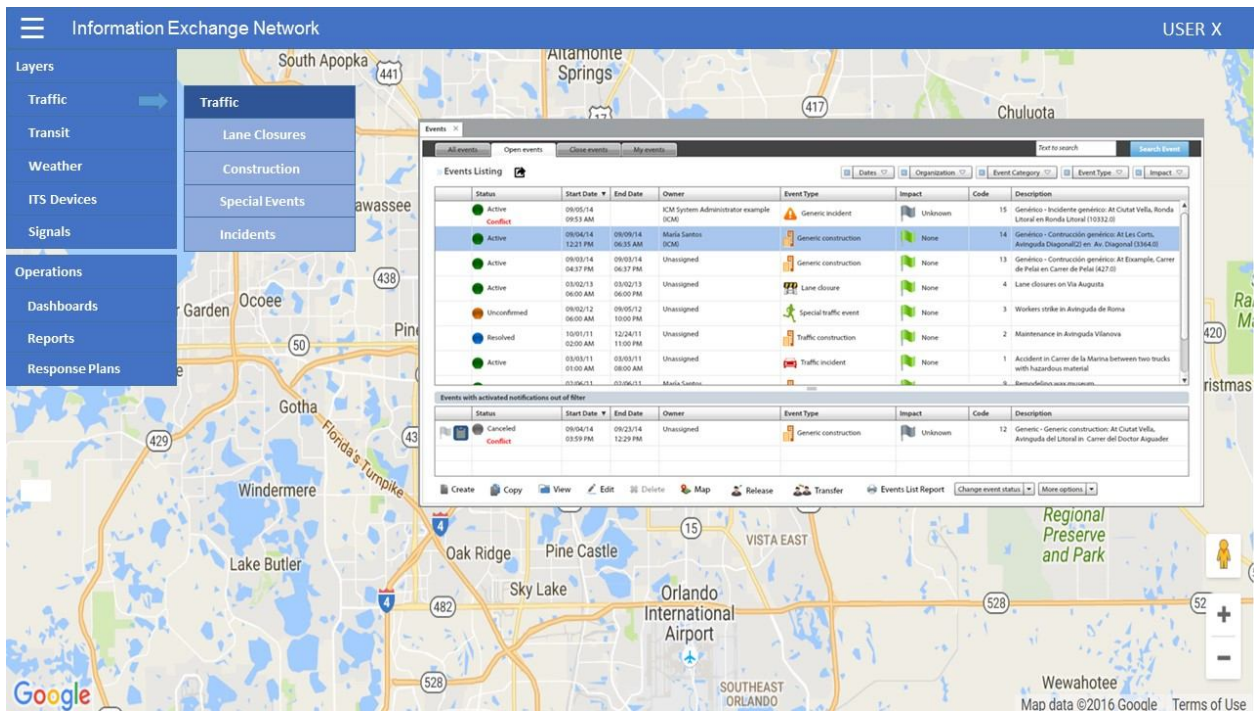

Figure 8: IEN Event List